



Mahindra TRACTORS

OPERATOR'S MANUAL

1640 SHUTTLE
1640 H S T
1640 H S T CABIN



GENERAL TABLE OF CONTENTS

Safety/Decals	1-14
Specifications	15-20
Instruments/Controls	21-39
Operating Instructions	40-63
Field Operation	64-73
Tires/Wheels/Spacing/Ballast	74-80
Lubrication/Filters/Fluids	81-110
Maintenance/Adjustments	111-118
Electrical System	119-125
Storage	126-129
Cabin	130-143
Optional Equipment	144-147

ABOUT THIS MANUAL

This Manual has been prepared to assist you in following the correct procedure for break-in, operation and maintenance of your new Mahindra tractor.

Your tractor has been designed and built to give maximum performance, with good fuel economy and ease of operation under a wide variety of operating conditions. Prior to delivery, the tractor was carefully inspected, both at the factory and by your Mahindra dealer, to ensure that it reaches you in optimum condition. To maintain this condition and ensure trouble free performance, it is important that the routine service, as specified in this manual, are carried out at the recommended intervals.

Read this manual carefully and keep it in a convenient place for future reference. If at any time you require advice concerning your tractor, do not hesitate to contact your authorised Mahindra dealer. He has trained personnel, genuine Mahindra parts and necessary equipment to undertake all your service requirements.

Mahindra USA Inc's. policy is one of continuous improvement, and the right to change prices, specifications or equipment at any time without notice is reserved.

All data given in this book is subject to production variations. Dimension & weight are approximate only and the illustrations do not necessarily show tractors in standard condition. For exact information about any particular tractor, please consult your Mahindra dealer.

Emission Control Warranty for California

Product Warranty

Product warranty is provided as part of Mahindra & Mahindra Limited support program for customers who operate and maintain their equipment as described in this manual.

Engine related warranties stated in this manual refer only to emissions-related parts and components of your engine. The complete engine warranty, less emission-related parts and components, is provided separately as the Limited Warranty for New Mahindra & Mahindra Limited Commercial & Consumer Equipment.

Mahindra & Mahindra Limited And California Emission Control System Warranty (heavy duty off-road Compression ignition engines)

Your Warranty Rights and Obligations

The California Air Resources Board (CARB) and Mahindra & Mahindra Limited are pleased to explain the emission control system warranty on your heavy duty off-road compression ignition engine. In California, new heavy-duty off road compression ignition engines must be designed, built and equipped to meet the State's stringent anti-smog standards. Mahindra & Mahindra Limited must warrant the emission control system on your heavy duty off-road compression ignition engine for the periods of time listed below provided there has been no abuse, neglect or improper maintenance of your engine.

Your emission control system may include parts such as the fuel-injection system and the air induction system. Also included may be hoses, belts, connectors and other emission-related assemblies.

Where a warrantable condition exists, Mahindra & Mahindra Limited will repair your heavy duty off-road compression ignition engine at no cost to you including diagnosis, parts and labor.

Mahindra & Mahindra Limited Emission Control System Warranty Coverage

In California, heavy duty off-road compression ignition engine emissions control-related parts are warranted by Mahindra & Mahindra Limited for five years or 3000 hours of operation, whichever occurs first. If any emission related part on your engine is defective, the part will be repaired or replaced by Mahindra & Mahindra Limited.

Owner's Warranty Responsibilities

As the heavy duty off-road compression ignition engine owner, you are responsible for the performance of the required maintenance listed in your owner's manual. Mahindra & Mahindra Limited recommends that you retain all receipts covering

maintenance on your heavy duty off-road engine, but Mahindra & Mahindra Limited cannot deny warranty solely for lack of receipts or for your failure to ensure the performance of all scheduled maintenance.

As the heavy duty off-road engine owner, you should however be aware that Mahindra & Mahindra Limited may deny you warranty coverage if your heavy duty off-road engine or a part has failed due to abuse, neglect, improper maintenance or unapproved modifications.

Your engine is designed to operate on ultra low sulphur diesel only. Use of any other fuel may result in your engine no longer operating in compliance with California's emissions requirements.

You are responsible for initiating the warranty process. The CARB suggests that you present your heavy duty off-road engine to an authorized Mahindra & Mahindra Limited Commercial and Consumer Equipment Dealer / Retailer as soon as a problem exists. The warranty repairs should be completed in a reasonable amount of time, not to exceed 30 days.

"If you have any question regarding your warranty rights and responsibilities, you should contact Mahindra, USA Inc at 1-877-449-7771.

Length of Warranty Coverage

Mahindra & Mahindra Limited warrants to the initial owner and each subsequent purchaser that the heavy duty off-road compression ignition engine is:

- Designed, built and equipped so as to conform with all applicable regulations adopted by the California Air Resources Board (CARB) pursuant to its authority in Chapters 1 and 2, Part, Division 26 of the Health and Safety Code; and
- Free from defects in materials and workmanship which can cause the failure of a warranted part to be identical in all material respects to the part as described in the application of Mahindra & Mahindra Limited for certification for a period of five years or 3000 hours of operation, whichever occurs first, after the engine is delivered to the initial retail purchaser. Mahindra & Mahindra Limited is liable for damages to other engine components caused by the failure of a warranted part during the warranty period. If any emission related part on your engine is defective, the part will be repaired or replaced by Mahindra & Mahindra Limited.

Warranted Parts

Coverage under this warranty extends only to the parts listed (the emission control system parts) to the extent these parts were present on the engine purchased.

Emission Control Warranty for California

Fuel Metering System:

- Fuel Injection Pump
- Common Rail
- CR Injector

Air Induction System:

- Intake Manifold
- Intake Elbow

Electrical Exhaust Gas Recirculation (EGR) System:

- EGR Valve
- EGR Rate Feedback and Control System

Positive Crankcase Ventilation (PCV) System:

- Oil Filler Cap
- Oil Separator

Miscellaneous items used in above systems:

- Electronic Control Unit (ECU)
- Phase Sensor
- Speed Sensor
- Coolant Temperature Sensor
- Accelerator Pedal Sensor
- Hoses, connectors, assemblies, clamps, fittings, tubing, sealing gaskets and mounting hardware

Warranty Service and Charges

Warranty service shall be provided during customary business hours at any authorized Mahindra & Mahindra Limited Commercial and Consumer Equipment Retailer. Repair or replacement of any warranted part will be performed at no charge to the owner, including diagnostic labor which leads to the determination that a warranted part is defective, if the diagnostic work is performed at an authorized Mahindra & Mahindra Limited Commercial and Consumer Equipment Retailer. Any parts replaced under this warranty shall become the property of Mahindra & Mahindra Limited.

Maintenance Warranty Coverage

- a) Any warranted part which is not scheduled for replacement as required maintenance shall be warranted for the warranty period defined in subsection "Length of Warranty Coverage." If any such part fails during the period of warranty coverage, it shall be repaired or replaced by Mahindra & Mahindra Limited. Any such part repaired or replaced under the warranty shall be warranted for the remaining warranty period.

- b) Any warranted part which is scheduled only for regular inspection shall be warranted for the warranty period defined in subsection "Length of Warranty Coverage" to the effect of "repair or replace as necessary" shall not reduce the period of warranty coverage. Any such part repaired or replaced under the warranty shall be warranted for the remaining warranty period.

- c) Any warranted part which is scheduled for replacement as required maintenance shall be warranted for the period of time prior to the first scheduled replacement point for that part. If the part fails prior to the first scheduled replacement, the part shall be repaired or replaced by Mahindra & Mahindra Limited. Any such part repaired or replaced under the warranty shall be warranted for the remainder of the period prior to the first scheduled replacement point for that part.

- d) Repair or replacement of any warranted part under the warranty provision of this statement shall be performed at no charge to the owner at an authorized Mahindra & Mahindra Limited warranty station.

- e) Notwithstanding the provisions of subsection "d" above, warranty services or repairs shall be provided at all authorized Mahindra & Mahindra Limited Commercial and Consumer Equipment Retailer and distribution centers that are franchised to service the subject engines.

- f) The owner shall not be charged for diagnostic labor that leads to the determination that a warranted part is in fact defective, provided that such diagnostic work is performed at an authorized Mahindra & Mahindra Limited warranty station.

- g) Mahindra & Mahindra Limited shall be liable for damages to other engine components proximately caused by a failure under warranty of any warranted part.

- h) Throughout the engine's warranty period defined in subsection "Length of Warranty Coverage", Mahindra & Mahindra Limited shall maintain a supply of warranted parts sufficient to meet the expected demand for such parts.

- i) Any replacement part may be used in the performance of any maintenance or repairs and must be provided without charge to the owner. It is not necessary for replacement parts to be the same brand or by the same manufacturer as the original part sold with the engine. Such use shall not reduce the warranty obligations of Mahindra & Mahindra Limited.

Emission Control Warranty for California

- j) Add-on or modified parts may not be used. Such use shall be grounds for disallowing a warranty claim made in accordance with this warranty statement shall not be liable under this article to warrant failures of warranted parts caused by the use of such an add-on or modified part.
- k) The Executive Officer may request and in such case, Mahindra & Mahindra Limited shall provide, any documents which describe warranty procedures or policies of Mahindra & Mahindra Limited.

Consequential Warranty Coverage

Warranty coverage shall extend to the failure of any engine components caused by the failure of any warranted part still under warranty.

Limitations

This Emission Control System Warranty shall NOT cover any of the following:

- a) Repair or replacement required as a result of (i) misuse or neglect, (ii) improper maintenance or unapproved modifications, (iii) repairs improperly performed or replacements improperly installed, (iv) use of replacement parts or accessories not conforming to Mahindra & Mahindra Limited specifications which adversely affect performance and/or durability, (v) alterations or modifications not recommended or approved in writing by Mahindra & Mahindra Limited.
- b) Replacement parts, other services and adjustments necessary for normal maintenance.
- c) Transportation to and from the Mahindra & Mahindra Limited Commercial and Consumer

Equipment Retailer, or service calls made by the Retailer.

Limited Liability

- a) The liability of Mahindra & Mahindra Limited under this Emission Control System Warranty is limited solely to the remedying of defects in materials or workmanship. This warranty does not cover inconvenience or loss of use of the heavy duty off-road compression ignition engine or transportation of the engine to or from the Mahindra & Mahindra Limited Commercial and Consumer Equipment Retailer. Mahindra & Mahindra Limited SHALL NOT BE LIABLE FOR ANY OTHER EXPENSE, LOSS, OR DAMAGE, WHETHER DIRECT, INCIDENTAL, CONSEQUENTIAL (EXCEPT AS LISTED ABOVE UNDER "COVERAGE") OR EXEMPLARY ARISING IN CONNECTION WITH THE SALE OR USE OF OR INABILITY TO USE THE HEAVY DUTY OFF-ROAD COMPRESSION IGNITION ENGINE FOR ANY OTHER PURPOSE.
- b) NO EXPRESS EMISSION CONTROL SYSTEM WARRANTY IS GIVEN BY Mahindra & Mahindra Limited WITH RESPECT TO THE ENGINE EXCEPT AS SPECIFICALLY SET FORTH IN THIS DOCUMENT. ANY EMISSION CONTROL SYSTEM WARRANTY IMPLIED BY LAW, INCLUDING ANY WARRANTY OF MERCHANTABILITY OR FITNESS FOR A PARTICULAR PURPOSE, IS EXPRESSLY LIMITED TO THE EMISSION CONTROL SYSTEM WARRANTY TERMS SET FORTH IN THIS DOCUMENT.
- c) No dealer is authorized to modify this California and Mahindra & Mahindra Limited Emission Control System Warranty.

Emission Control Warranty for Federal

Product Warranty

Product warranty is provided as part of Mahindra & Mahindra Limited support program for customers who operate and maintain their equipment as described in this manual.

Engine related warranties stated in this manual refer only to emissions-related parts and components of your engine. The complete engine warranty, less emission-related parts and components, is provided separately as the Limited Warranty for New Mahindra & Mahindra Limited Commercial & Consumer Equipment.

Mahindra & Mahindra Limited, Federal Emission Control System Warranty (Non-Road Diesel)

Your Warranty Rights and Obligations

The United States Environmental Protection Agency (EPA) and Mahindra & Mahindra Limited are pleased to explain the emission control system warranty on your non-road diesel equipment engines must be designed, built and equipped to meet the U.S. EPA regulations for non-road diesel engines. Mahindra & Mahindra Limited must warrant the emission control system on your non-road diesel equipment engine for the periods of time listed below provided there has been no abuse, neglect or improper maintenance of your non-road diesel equipment engine.

Your emission control system may include parts such as the fuel-injection system and the air induction system. Also included may be connectors and other emission related assemblies.

Where a warrantable condition exists, Mahindra & Mahindra Limited will repair your non-road diesel equipment engine at no cost to you including diagnosis, parts and labor.

Mahindra & Mahindra Limited Emission Control System Warranty Coverage

Your non-road diesel equipment engine emissions control-related parts are warranted by Mahindra & Mahindra Limited for five years or 3000 hours of operation, whichever occurs first. If any emission related part on your engine is defective, the part will be repaired or replaced by Mahindra & Mahindra Limited.

Owner's Warranty Responsibilities

As the non-road diesel equipment engine owner, you are responsible for the performance of the required

maintenance listed in your owner's manual. Mahindra & Mahindra Limited recommends that you retain all receipts covering maintenance on your non-road diesel equipment engine, but Mahindra & Mahindra Limited cannot deny warranty solely for lack of receipts or for your failure to ensure all scheduled maintenance is performed.

As the non-road diesel equipment engine owner, you should however be aware that Mahindra & Mahindra Limited may deny you warranty coverage if your non-road diesel equipment engine or a part has failed due to abuse, neglect, improper maintenance or unapproved modifications.

You are responsible for presenting your non-road diesel equipment engine to an authorized Mahindra & Mahindra Limited Commercial and Consumer Equipment Retailer as soon as a problem exists. The warranty repairs should be completed in a reasonable amount of time, not to exceed 30 days.

"If you have any question regarding your warranty rights and responsibilities, you should contact (Mahindra, USA Inc) at 1-877-449-7771.

Length of Warranty Coverage

Mahindra & Mahindra Limited warrants to the initial owner and each subsequent purchaser that the non-road diesel equipment engine is:

- Designed, built and equipped so as to conform with all applicable regulations of the United States Environmental Protection Agency (EPA) for non-road diesel equipment engines;
- Free from defects in materials and workmanship which can cause the failure of an emission warranted part for a period of five years or 3000 hours of operation, whichever occurs first, after the engine is delivered to the initial retail purchaser. Mahindra & Mahindra Limited is liable for damages to other engine components caused by the failure of a warranted part during the warranty period. If any emission related part on your engine is defective, the part will be repaired or replaced by Mahindra & Mahindra Limited.

Warranted Parts

Coverage under this warranty extends only to the parts listed below (the emission control system parts) to the extent these parts were present on the engine purchased.

Emission Control Warranty for Federal

Fuel Metering System:

- Fuel Injection Pump
- Common Rail
- CR Injector

Air Induction System:

- Intake Manifold
- Intake Elbow

Electrical Exhaust Gas Recirculation (EGR) System:

- EGR Valve
- EGR Rate Feedback and Control System

Positive Crankcase Ventilation (PCV) System:

- Oil Filler Cap
- Oil Separator

Miscellaneous items used in above systems:

- Electronic Control Unit (ECU)
- Phase Sensor
- Speed Sensor
- Coolant Temperature Sensor
- Accelerator Pedal Sensor
- Hoses, connectors, assemblies, clamps, fittings, tubing, sealing gaskets and mounting hardware

Since emission related parts may vary slightly from model to model, certain models may not contain all of these parts and certain models may contain functionally equivalent parts.

Warranty Service and Charges

Warranty service shall be provided during customary business hours at any authorized Mahindra & Mahindra Limited Commercial and Consumer Equipment Retailer. Repair or replacement of any warranted part will be performed at no charge to the owner, including diagnostic labor which leads to the determination that a warranted part is defective, if the diagnostic work is performed at an authorized Mahindra & Mahindra Limited Commercial and Consumer Equipment Retailer. Any parts replaced under this warranty shall become the property of Mahindra & Mahindra Limited.

Maintenance Warranty Coverage

- a) Any warranted part which is not scheduled for replacement as required maintenance shall be warranted as to defects for the warranty period. Any such part repaired or replaced under the

warranty shall be warranted for the remaining warranty period.

- b) Any warranted part which is scheduled only for regular inspection to the effect of "repair or replace as necessary" shall be warranted as to defects for the warranty period. Any such part repaired or replaced under the warranty shall be warranted for the remaining warranty period.
- c) Any warranted part which is scheduled for replacement as required maintenance shall be warranted as to defects only for the period of time up to the first scheduled replacement for that part. Any such part repaired or replaced under the warranty shall be warranted for the remainder of the period prior to the first scheduled replacement point for that part.
- d) Normal maintenance, replacement or repair of emission control devices and systems, which are being done at the customer's expense, may be performed by any repair establishment or individual; however, warranty repairs must be performed by an authorized Mahindra & Mahindra Limited Commercial and Consumer Equipment Retailer.
- e) Any replacement part that is equivalent in performance and durability may be used in the performance of any non-warranty maintenance or repairs, and shall not reduce the warranty obligations of Mahindra & Mahindra Limited.
- f) The owner shall not be charged for diagnostic labor that leads to the determination that a warranted part is in fact defective, provided that such diagnostic work is performed at an authorized Mahindra & Mahindra Limited warranty station.
- g) Mahindra & Mahindra Limited shall be liable for damages to other engine components proximately caused by a failure under warranty of any warranted part.
- h) Throughout the engine's warranty period defined in subsection "Length of Warranty Coverage", Mahindra & Mahindra Limited shall maintain a supply of warranted parts sufficient to meet the expected demand for such parts.

Consequential Warranty Coverage

Warranty coverage shall extend to the failure of any engine components caused by the failure of any warranted part still under warranty.

Limitations

This Emission Control System Warranty shall NOT cover any of the following:

Emission Control Warranty for Federal

- a) Repair or replacement required as a result of (i) misuse or neglect, (ii) improper maintenance or unapproved modifications, (iii) repairs improperly performed or replacements improperly installed, (iv) use of replacement parts or accessories not conforming to Mahindra & Mahindra Limited specifications which adversely affect performance and/or durability, (v) alterations or modifications not recommended or approved in writing by Mahindra & Mahindra Limited.
- b) Replacement parts, other services and adjustments necessary for normal maintenance.
- c) Transportation to and from the Mahindra & Mahindra Limited Commercial and Consumer Equipment Retailer, or service calls made by the Retailer.

Limited Liability

- a) The liability of Mahindra & Mahindra Limited under this Emission Control System Warranty is limited solely to the remedying of defects in materials or workmanship. This warranty does not cover inconvenience or loss of use of the non-road diesel equipment engine or transportation of the

engine to or from the Mahindra & Mahindra Limited Commercial and Consumer Equipment Retailer. Mahindra & Mahindra Limited SHALL NOT BE LIABLE FOR ANY OTHER EXPENSE, LOSS, OR DAMAGE, WHETHER DIRECT, INCIDENTAL, CONSEQUENTIAL (EXCEPT AS LISTED ABOVE UNDER "COVERAGE") OR EXEMPLARY ARISING IN CONNECTION WITH THE SALE OR USE OF OR INABILITY TO USE THE NON-ROAD DIESEL ENGINE FOR ANY OTHER PURPOSE.

- b) NO EXPRESS EMISSION CONTROL SYSTEM WARRANTY IS GIVEN BY Mahindra & Mahindra Limited WITH RESPECT TO THE ENGINE EXCEPT AS SPECIFICALLY SET FORTH IN THIS DOCUMENT. ANY EMISSION CONTROL SYSTEM WARRANTY IMPLIED BY LAW, INCLUDING ANY WARRANTY OF MERCHANTABILITY OR FITNESS FOR A PARTICULAR PURPOSE, IS EXPRESSLY LIMITED TO THE EMISSION CONTROL SYSTEM WARRANTY TERMS SET FORTH IN THIS DOCUMENT.
- c) No dealer is authorized to modify this Federal and Mahindra & Mahindra Limited Emission Control System Warranty.

INTRODUCTION

This instruction manual contains information on the operation, lubrication and maintenance of your tractor. The information contained is comprehensive and essential, and is designed to assist you, even if unexperienced, in utilizing your tractor.

How well your tractor continues to give satisfactory performance depends greatly upon the manner in which it is operated. It is, therefore, requested that this manual be read carefully and kept ready for use so that the operation and maintenance service will properly be carried out in order to keep the tractor in top mechanical condition at all times.

Should any information as to your tractor be required, consult your local dealer or distributor stating the machine and engine serial numbers of the tractor concerned. We are sure you will be happy with your tractor.

NOTE: Expressions such as LEFT, RIGHT, FRONT, or REAR used in this manual should be understood in accordance with following rules:

FRONT means the front grill end while REAR means the lifting arm end of the tractor. LEFT or RIGHT means the left or right hand side of the tractor looking forward from operator's seat.

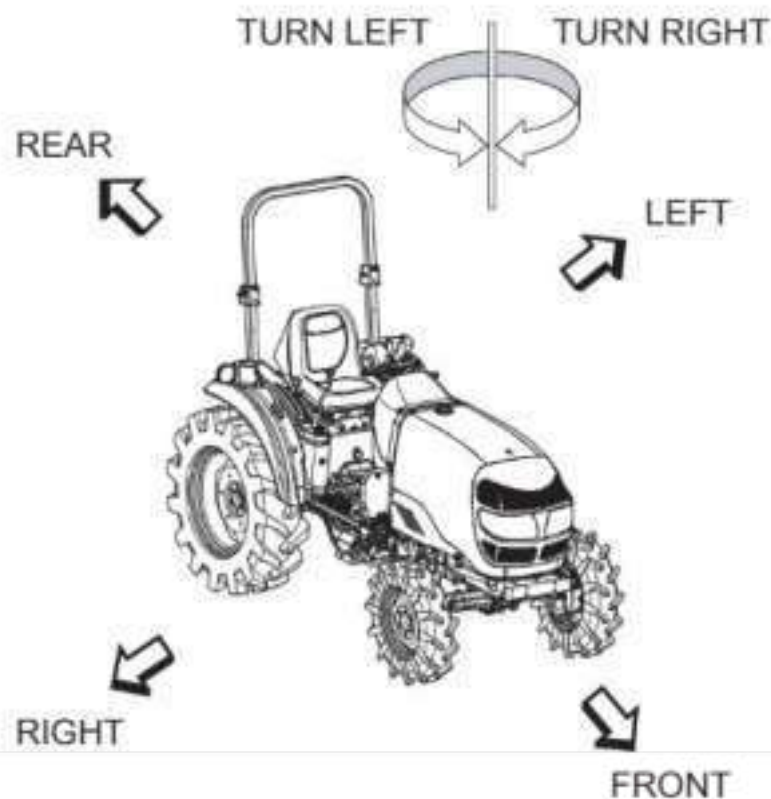

SERIAL NUMBERS

SERIAL NUMBER

Write your machine Model Name and Serial Numbers of major components on the lines provided. If needed, give these numbers to your dealer when you need parts or information for your machine.

1. TRACTOR MODEL NUMBER _____

2. TRACTOR SERIAL NUMBER _____

3. ENGINE SERIAL NUMBER _____

4. ROPS SERIAL NUMBER(Only Open Model) _____

5. CABIN SERIAL NUMBER(Only CABIN Model) _____

SERIAL NUMBER LOCATIONS

TRACTOR MODEL NUMBER AND SERIAL NUMBER PLATE

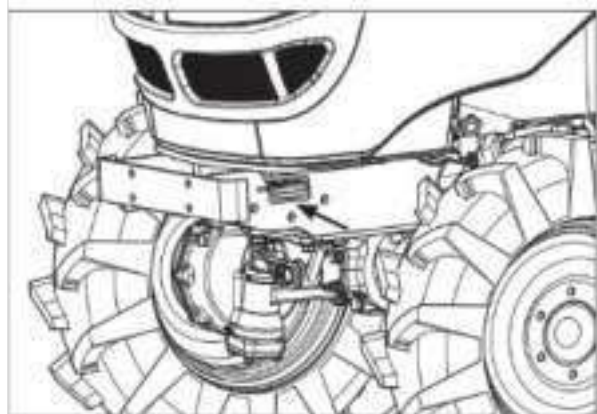

ROPS SERIAL NUMBER PLATE

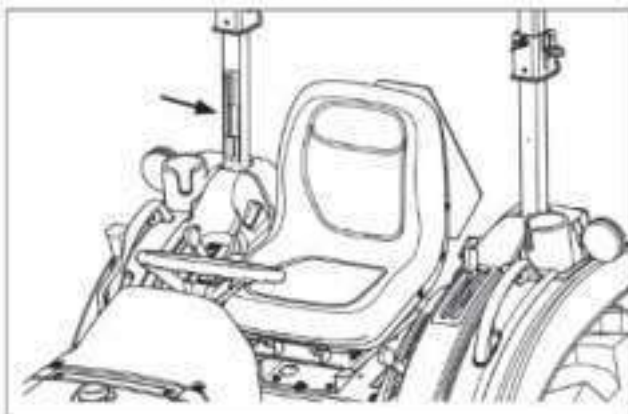

ENGINE SERIAL NUMBER

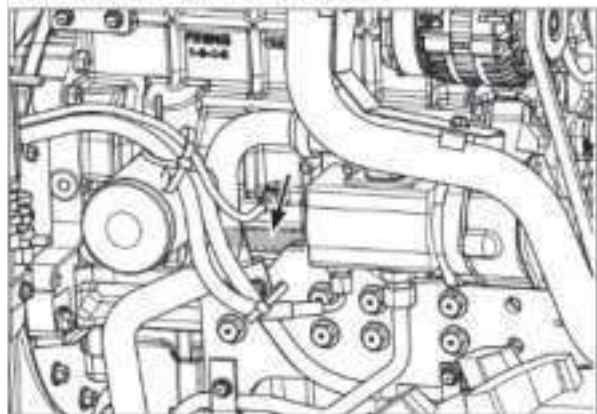

CABIN SERIAL NUMBER PLATE

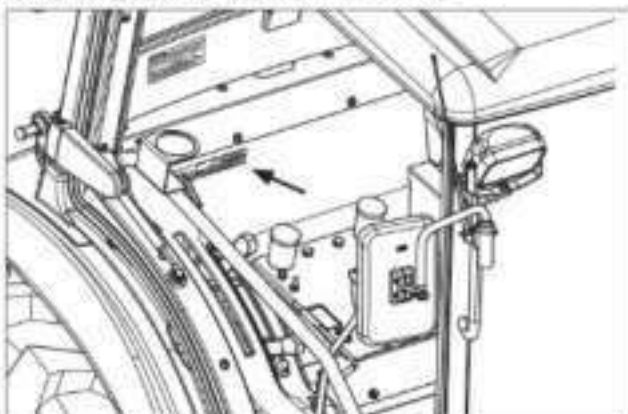

SAFETY PRECAUTIONS

REMEMBER: "SAFETY" IS ONLY A WORD UNTIL IT IS PUT INTO PRACTICE

Improper handling of the tractor could cause an accident. Prior to the operation of the tractor, be sure to read this Manual carefully and have a through understanding of all of the contents. In particular, the instructions given in this section entitled "Safety Precautions" must be strictly followed.

A. GENERAL OPERATING SAFETY PRECAUTION

1. Observe all the safety precautions in this manual when operating the tractor.
2. Operate the tractor while wearing tight clothing that allows easy movement. Avoid loose jackets, mufflers, ties, scarves, or loose shirt sleeves to prevent from being caught by moving parts.
5. Never allows riders on the tractor, linkage drawbar or attachment while traveling and operating them.



B. BASIC SAFETY REQUIREMENTS FOR MAINTENANCE

3. Always work when you are in good physical condition by taking sufficient rest to avoid overwork.
4. Do not allow children or adults having no knowledge of the tractor or tractor operation, to operate the tractor.

Always follow these maintenance instructions before operating the tractor:

1. Immediately repair the head lights and work lamps required to conform to traffic regulations where the tractor is operated.
2. Keep tractor steps clean to avoid accidents due to slippage.

3. Cover the PTO shaft with a guard when not using.
4. Be sure to engage the brake and lower any attachment or implement before disassembling any part.
5. Never adjust or service the tractor when it is in motion or while the engine is running. Always adjust the brake or clutch properly in accordance with the adjusting procedure in the instruction book.
6. Do not remove the radiator cap while the engine is running. Shut down the engine and wait until it cools sufficiently. For removal, turn the cap to the first stop to relieve pressure. To replace the coolant, use the coolant recovery tank.
7. Hydraulic oil or fuel escaping under pressure can penetrate the skin, causing serious injury. Before disconnecting oil or fuel lines, be sure to relieve all pressure. Before restoring pressure after repair, be sure all connections are tight and all hydraulic components are in normal condition. If injured by leaked fluid, see a doctor immediately for proper treatment.
8. When refueling, be particularly careful first to stop the engine completely to prevent the fuel from igniting. Never refuel in the presence of an open flame or while smoking.



SAFETY/DECALS

9. Before starting any work on electrical equipment or work that may cause you to touch the electrical parts accidentally, first disconnect the battery cables. Never remove the rubber cap cover at the positive terminal of the battery cable end. Before connecting the battery to the charger, make sure that the charger switch is in "OFF" position.

Be sure to connect the charger to the correct terminals on the battery (positive to positive, negative to negative).

A great amount of hydrogen gas is generated by the battery when it is being charged. Take precautions against fire: Do not have any exposed flame in the area where you are working.

Be sure not to cause any leakage of the electrolyte, since it will corrode the skin or clothing. In case of accident as described below, immediately seek first aid, and see a doctor immediately for proper treatment.

- a) If the diluted sulphuric acid from the battery has gotten into the eyes:
Clean the eyes with a lot of clean running water for more than 15 minutes, while opening the eyes widely, and see a doctor immediately for proper treatment.
- b) If the diluted sulphuric acid from the battery has been swallowed: Rinse the mouth with clean water immediately, and see a doctor immediately for proper treatment.
- c) If diluted sulphuric acid has gotten on the skin or clothing: Wash away the diluted sulphuric acid completely with a lot of clean running water and neutralize with soap solution. Then rinse with water.

d) If the diluted sulphuric acid is spilled: Wash away with a lot of water or neutralize with slacked lime or bicarbonate of soda.

10. Stop the engine and make sure the PTO shift lever is in Neutral before performing any of the following services, including.

a) Removal of the propeller shaft between PTO and any attachment.

b) Adjustment of PTO drive train and hitch.

c) Adjustment or cleaning of PTO driven attachment.

11. The steering wheel always has built-in play to some extent, which is required for smooth meshing of sector gear and pinion gear.

Always inspect the amount of the play. Do not operate the tractor if there is too much or too little play in the steering.

C. OPERATION OF THE TRACTOR

Before driving the tractor, follow these rules:

1. Before starting and Driving the Tractor

Operate the tractor only when seated properly in operator's seat and keep a firm grip on the steering wheel at all times.

Never attempt to perform any operation of the tractor from anywhere else, on or off the tractor. Always wear a "hard hat" when operating the tractor.

2. Starting and Driving the Tractor

Always operate the tractor at the proper speeds which enable you to keep the tractor in complete control.



To start traveling, lower the engine speed and release the clutch pedal slowly.

Before leaving the tractor, stop the engine, remove the key, apply the parking brake and make sure that the engine has come to a complete stop, and any attachment is completely touching the ground.



SAFETY/DECALS

Slow down when operating the tractor on rough ground.



Never attempt to jump on or off from moving tractor.



When starting the tractor, operating any attachment or engaging the PTO, make sure that no one is in the way, especially children.



When starting the engine in an enclosed area or building, ensure proper ventilation by opening the doors and/or windows to prevent carbon monoxide inhalation. Mount the extension exhaust pipe on the tractor which has a cabin.



3. Traveling on Roads and Streets

For traveling on roads and streets, be sure to lock both brake pedals together before driving to prevent either brake from acting independently.



Never operate the differential lock while driving at high speed or traveling on the road. For driving the MFD tractor on the road, be sure to place the MFD shift lever in OFF position.

4. Steering and Turning the Tractor

Slow down your tractor and disengage the differential lock before going into a turn, being careful to prevent any attachments mounted on the front or rear from hitting anyone or anything.

5. Towing and Operating on Hills

For towing work on downward slope, place the shift lever in low speed and use engine brake.

Never try to reduce the speed with brake only.

Towing a heavy object on a hill is highly hazardous. Widen the tread of the tractor and mount the wheel weight or chassis weight to increase the stability and operate with extra precaution.



SAFETY/DECALS

When operating the tractor on either a steep slope or flat ground, be sure not to suddenly steer, brake, clutch or operate attachments.

Do not operate the tractor at the edge of cliff or slope. Be particularly careful right after the rain when soil is soft and may give way easily.



For towing, be sure to use the drawbar only. Set the hitch point below the center line of the rear axle. When using a chain, never try to move forward abruptly.



Avoid operating the tractor on an extreme slope that appears hazardous, when forced to operate on such slope, use extra care. Driving forward out of a ditch or mired condition or up a steep slope could cause tractor to tip over rearward.

Back out of such situation does not permit you back out, use the front wheel weight or the chassis weight for balancing the tractor lengthwise. Also in case any extra-heavy rear mounting. Attachments is used, try to obtain better balance in this manner.

6. Using Attachment

To mount or operate attachment, follow the instruction manual for the particular attachment for safe operation.



When using agricultural chemicals with an attachment on the tractor, always follow the instructions in the manual for the attachment as well as the instructions provided by the chemical manufacturer.

DECALS

IMPORTANT: Install new decals if the old decals are destroyed, lost, painted over or can not be read. When parts are replaced that have decals, make sure you install a new decal with each new part.

NOTE: New decals are available from your Dealer.

**WARNING**

EXPLOSION AND INJURY CAN RESULT FROM USE OF STARTING AIDS WITH HOT GLOW PLUGS. DO NOT INJECT GASOLINE OR ETHER IN AIR INTAKE.

**WARNING**

BATTERIES CONTAIN ACID AND EXPLOSIVE GAS. EXPLOSION CAN RESULT FROM SPARKS, FLAMES, OR WRONG CABLE CONNECTIONS. TO CONNECT JUMPER CABLES OR CHARGER, SEE MANUAL(S) FOR THE CORRECT PROCEDURE. FAILURE TO FOLLOW THE ABOVE INSTRUCTIONS CAN CAUSE SERIOUS PERSONAL INJURY OR DEATH.

321-6714

**WARNING****ROTATING MACHINE PARTS**

STAY CLEAR, KEEP SHIELDS INSTALLED TO HELP PROTECT FROM CLOTHING ENANGLEMENT AND INJURY.

321-3739

SAFETY/DECALS



<p>WARNING</p> <p>AVOID INJURY OR DEATH</p> <p>BEFORE STARTING ENGINE:</p> <ul style="list-style-type: none"> • Read operator's manual for safety information and operating instructions. • Read all tractor safety signs. • Be sure other people are clear of tractor and equipment. • Be sure all gears shifted are in neutral or park and all PTO controls are off. • Start engine only from seat. • Shields are for your protection. Keep them in place. <p>OPERATION:</p> <ul style="list-style-type: none"> • With ROPS always buckle and adjust seat belt. 	<ul style="list-style-type: none"> • No riders on tractor or equipment. • Keep hands, feet and clothing away from power driven parts. • For road travel, couple brake pedals, use flashing warning lamps unless prohibited by law and keep 300' behind visible. <p>TRACTORS CAN BE UPSET.</p> <ul style="list-style-type: none"> • Reduce speed on turns and rough ground. Avoid steep slopes. • Avoid rear wheel lift. Only tow implement near hitch. <p>WHEN TRACTOR HAS STOPPED:</p> <ul style="list-style-type: none"> • Engage park lock or brake. • Lower implement to ground. • Disengage PTO, stop engine and wait for all movement to stop before servicing or cleaning equipment.
--	---



 <h1 style="margin: 0;">WARNING</h1>
<p>When improperly operated, this tractor can rollover or upset. Use of ROPS and seat belt minimize the possibility of injury or death if rollover or upset occurs. For low clearance use only, the ROPS can be lowered. NO protection is provided in this position and the seat belt should not be fastened. For all other uses, secure ROPS in upright position and fasten seat belt.</p>

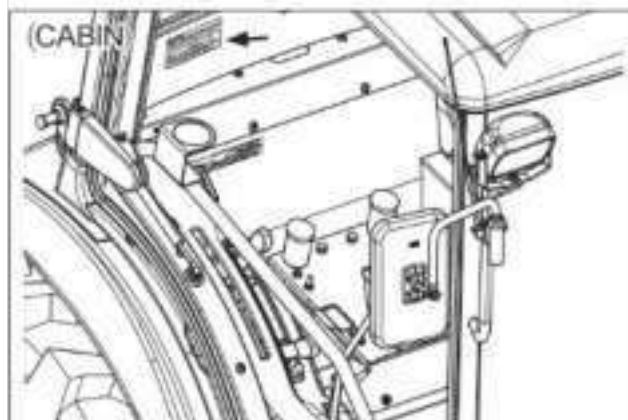

<p>CAUTION Refrigerant Under Pressure</p> <p>Improper service methods may cause injury. Air conditioning system SHOULD be serviced by a qualified personnel. See Service Manuals for Details.</p>	<table border="1" style="width: 100%; border-collapse: collapse;"> <tr> <td style="padding: 2px;"> Refrigerant HFC134a Net 1.03kg (2.27lb) USE ONLY Net 0.83kg (1.87lb) </td> <td style="padding: 2px;"> Oil NO-OIL 8 SAE OR EQUIVALENT 8 J-629 </td> </tr> </table> <p style="font-size: small;">MFD BY DENSO CORPORATION JAPAN 1040 8800</p>	Refrigerant HFC134a Net 1.03kg (2.27lb) USE ONLY Net 0.83kg (1.87lb)	Oil NO-OIL 8 SAE OR EQUIVALENT 8 J-629
Refrigerant HFC134a Net 1.03kg (2.27lb) USE ONLY Net 0.83kg (1.87lb)	Oil NO-OIL 8 SAE OR EQUIVALENT 8 J-629		

ROLL OVER PROTECTIVE STRUCTURE (ROPS)

Foldable ROPS Frame



When improperly operated, this tractor can roll over or upset. Use of the ROPS and seat belt minimize the possibility of injury or death if rollover or upset occurs. For low clearance use only, the ROPS can be lowered. No protection is provided in this position and the seat belt should not be fastened. For all other uses, secure the ROPS in the upright position and the fasten the seat belt.

ROPS is foldable so that the tractor can be operated in places such as orchards where the height is restricted. See Folding the ROPS in this manual.

Normal Operating Position

For normal operation, including transport, always use the foldable ROPS in the secured upright position with a fastened seat belt for full rollover protection.



SAFETY/DECALS

Low Clearance Positions

For low clearance operation, such as operating in buildings, orchards or vineyards, the ROPS can be lowered and secured in the lowered position.

No rollover protection is provided in the lowered positions and the seat belt should not be fastened. When the low clearance operation is completed, return the ROPS to the secured upright position for all other tractor uses and transport.



IMPORTANT: When the ROPS frame is in the lowered position, make sure there is clearance between the frame and hitch mounted equipment. Slowly raise the hitch to maximum height to check for necessary clearance. For drawbar attached and/or PTO driven equipment, check for clearance including turning corners.

Tractor Roll Over

ROPS is a special safety unit. After an accident, The ROPS must be replaced so that you will get the same protection as a new ROPS.

ROPS, the seat, the seat belts and all the mounting, accessories and wiring inside the operator's protective area must be carefully checked after a tractor accident and all parts with damage should be replaced immediately. DO NOT TRY TO MAKE REPAIRS WELDING THE ROPS.

Safety Rules

1. Do not make modification to the ROPS. Example, welding an accessory to the ROPS, or drilling a hole in the ROPS.
2. Special fasteners are used to install the operator protective parts. Replacement parts must be the same as given in the Parts Catalog for your tractor.

ROPS Label

1. ROPS is equipped with a ROPS label.
2. The label contains the ROPS serial number and applicable standards.

ROPS SERIAL NUMBER PLATE

 <small>MAHINDRA TRACTORS</small> <small>MAHINDRA TRACTORS</small>	<small>CONFORMS TO</small> MAHINDRA TRACTORS 1533, 1533H, 1536, 1536H 1640, 1640H AGRICULTURAL TRACTORS	<small>TYPE CERTIFICATION FOR</small> ROLLOVER PROTECTIVE STRUCTURES
	<small>CONFORMS TO</small> 1926 C	<small>PROTECTION OFFERED BY THIS ROPS</small> <small>WILL BE REDUCED IF THE ROPS IS</small> <small>REPLACED OR IF THERE IS DAMAGE,</small> <small>OR HAS BEEN SUBJECT TO IMPACT</small> <small>OR OPERATOR ERROR. FOR FULL</small> <small>PLATE INSTRUCTIONS AND INSPECTION</small> <small>REQUIREMENTS.</small>
<small>MAHINDRA TRACTORS</small> <small>MAHINDRA TRACTORS</small>		

CABIN SERIAL NUMBER PLATE

 <small>MAHINDRA TRACTORS</small> <small>MAHINDRA TRACTORS</small>	<small>CONFORMS TO</small> MAHINDRA TRACTORS 1533HX, 1536HX, 1640HX AGRICULTURAL TRACTORS	<small>TYPE CERTIFICATION FOR</small> ROLLOVER PROTECTIVE STRUCTURES
	<small>CONFORMS TO</small> 1926 C	<small>PROTECTION OFFERED BY THIS ROPS</small> <small>WILL BE REDUCED IF THE ROPS IS</small> <small>REPLACED OR IF THERE IS DAMAGE,</small> <small>OR HAS BEEN SUBJECT TO IMPACT</small> <small>OR OPERATOR ERROR. FOR FULL</small> <small>PLATE INSTRUCTIONS AND INSPECTION</small> <small>REQUIREMENTS.</small>
<small>MAHINDRA TRACTORS</small> <small>MAHINDRA TRACTORS</small>		

SAFETY/DECALS

Holding and Adjustment



STEP1

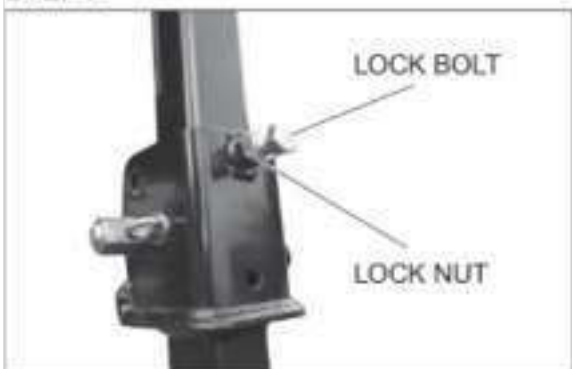

Loosen the lock nut and the lock bolt.

STEP2



Remove the lock pin from the position pin.

STEP3

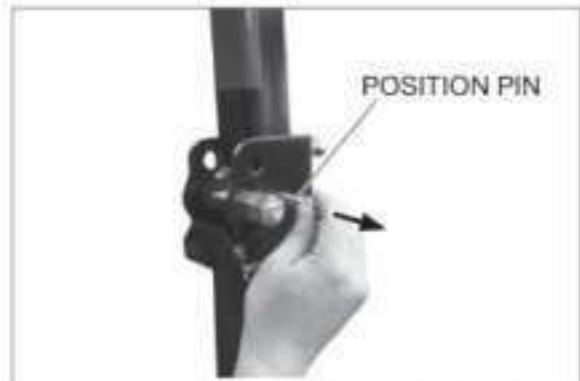

While holding the ROPS bar CAREFULLY remove the position pins.

STEP4



Down the ROPS bar slowly for the second position.

While holding the ROPS bar carefully install the position pins.

STEP5



Install the lock pin to the position pin.

SECOND POSITION



STEP6

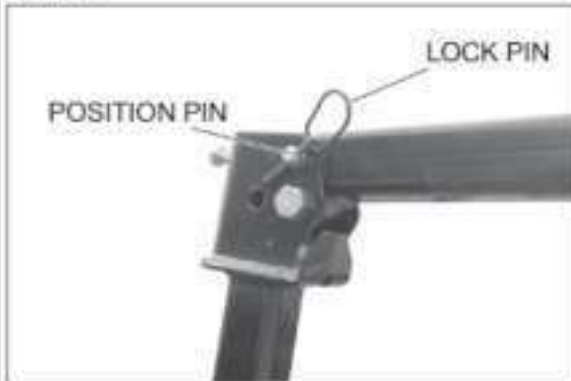

Remove the lock pin from the position pin.

STEP7



While holding the ROPS bar CAREFULLY remove the position pins.

STEP8

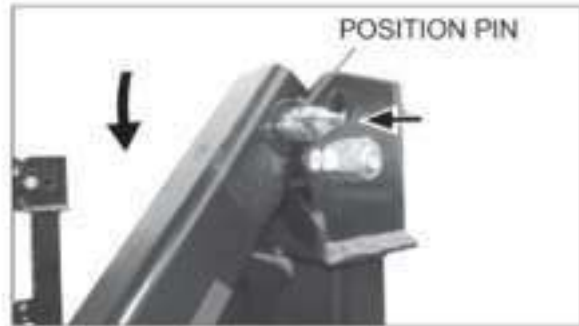

Down the ROPS bar slowly from the second position.

While holding the ROPS bar carefully install the position pins.

STEP9



Install the lock pin to the position pin.

STORED POSITION



Adjustment of Foldable ROPS.

If you feel less friction when the ROPS is at the upright position, tighten the Lock Nut until you feel the right friction in the movement.



WARNING: Rollover protection is provided only with proper assembly. Lock pins, must be in place. Correct parts may be obtained from your dealer.

SPECIFICATIONS

DIESEL ENGINE

General

Type	Four Stroke, Direct Injection Water cooled Natural Aspiration
Firing Order	1-3-4-2
Bore	88.9mm (3.5 inch)
Stroke	110mm (4.33 inch)
Piston Displacement	2732cm ³ (166.7 inch ³)
Compression Ratio	18.7 to 1
Governor Engine Speed without Load	2570 to 2630 RPM
Rated Engine Speed	2400 RPM
Engine Idle Speed	970 to 1030 RPM
*Maximum Horsepower (Manufacturing Rating).....	38.7 HP at 2400 RPM
Valve Clearance (Intake and Exhaust Cold Engine).....	Intake 0.25 mm (0.01 inch) Exhaust 0.3 mm (0.012 inch)

IMPORTANT: Valve clearance adjustment must be made when the engine is not running and is cold.

Engine Lubrication System

Oil Pressure	147kPa (21.3PSI) to 588kPa (85.3PSI) at 1000 Engine RPM with 15W-40 oil at 96°C (204.8°F)
--------------------	--

Fuel System

Fuel Injection Pump.....	BOSCH CB18-2L OHWCW
Fuel Injectors	BOSCH, CRI 2-16

*Manufacturer's estimate under standard condition and subject to change without prior notice.

Air Intake System

Type..... Dry Type Air Cleaning System

Cooling System

Type..... Pressure System, Thermostat
Controlled Bypass, Impeller Type Pump

Radiator..... New Rectangle Fin Type
Thermostat Start to Open at Approx. 80°C(176°F)
Fully Open at 96°C (204.8°F)

Pressure Cap..... 88.0kPa (12.8psi)

Water Temperature..... Thermometer on Instrument Panel

POWER TRAIN

Tractor Brakes

Type..... Wet Disk Plate Type

Operation..... Mechanical

Parking Brakes..... Hand Operating Lock Type

Transmission

Type

Gear Drive..... Synchronesh on shuttle shift (forward-reverse section)
and main Gear Shift of constant mesh with
Two Ranges of Selective Sliding Gears

Hydrostatic Drive..... Hydrostatic Transmission with Three Ranges of
Selective Sliding Gears

Gear Selection

Gear Drive..... 8 Speeds Forward and 8 Speeds Reverse

Hydrostatic Drive..... 3 Speed ranges in Forward and Reverse
with Variable Speeds.

Shift Control

Gear Drive..... Actuated by Two Shift Levers on the LH
Fender and shuttle lever on the column.

Hydrostatic Drive..... Actuated by Pedal on the RH Step and lever on the LH Fender

Oil Cooler..... Hydrostatic Drive only

SPECIFICATIONS

Clutch

Type, Diameter

Gear Drive	Dry, Single Disc, Diaphragm Type, 255mm (8.86 Inch)
Hydrostatic Drive	Dry, Single Disc, Diaphragm Type, 255mm (8.86 Inch)
Operation.....	Mechanical

Mechanical Front Drive (MFD)

Front Axle	Spiral Bevel Gear Type Differential with Bevel Gear Reductions
------------------	---

Differential Lock

Type

Gear Drive	Controlled by Pedal on the RH Step and Mechanically Actuated
Hydrostatic Drive	Controlled by Pedal on the LH Step and Mechanically Actuated

Steering

Type of Steering	Hydrostatic Type
------------------------	------------------

Hitch System

Type.....	Three Point, SAE Category 1
Type Control	Positions Control
Type Valve	Three Positions, Lift, Hold and lower
Lifting Capacity at 24"behind Lift Point (Per ASAE S349.1)	780kg (1720lbs)
Type of Cylinder.....	Single Acting Type

Hydraulic System

Hydraulic Pump Type	Front Mounted, Engine Driven, Pressure Loading Gear Type Capacity
Pump for Three Point Hitch	29 l/min (7.7GPM) at 2400 Engine RPM
Pump for Power Steering	12.8 l/min (3.4GPM) at 2400 Engine RPM
Maximum System Pressure.....	15.5MPa (2205psi)
Auxiliary Connector	Loader Valve Hydraulic Block
Connector Size	G 3/8

Rear Power Takeoff (PTO)

PTO Type	
Gear Drive	Independent PTO
Hydrostatic Drive	Live PTO (Internal over running clutch)
Location	At the rear of transmission
Rotation	Clockwise from rear of tractor
Shaft Size	34.9 mm (1.375 Inch) Diameter, 6Splines
Speed	540 RPM at 2376 Engine RPM

Mid Power Takeoff (PTO) OPTION

PTO Type	
Gear Drive	Independent PTO
Hydrostatic Drive	Live PTO (Internal over running clutch)
Location	At the Bottom of Transmission
Rotation	Clockwise from Rear of Tractor
Shaft Size	25.4mm (1 Inch) Diameter, 15Splines
Speed	2000 RPM at 2526 Engine RPM

Drawbar

Type.....	Fixed Type
Distance from Hitch Hole to the End of PTO Shaft.....	358mm (14.092 inch)
Maximum Vertical Load on Drawbar.....	440kgf (969lbf)

SPECIFICATIONS

Overall length (To end of Lower link)3245 mm (127.8 inch)

Overall width (To end of tire)

1640(43x16.00 - 20) 1575 mm (62 inch)

Height (To top of ROPS)

1640(43x16.00 - 20) 2325 mm (91.5 inch)

1640CABIN(43x16.00 - 20) 2270 mm (89.4 inch)

Wheel base 1954 mm (76.9 inch)

Ground Clearance

1640(28x8.50 - 15) 325 mm (12.8 inch)

Turning Radius (with Brake Assistance)2800 mm (110.4inch)

Weight

1640 Gear Drive (43x16.00-20) 1445 kg (3186 lbs)

1640 Hydrostatic Drive (43x16.00-20) 1440 kg (3175 lbs)

1640 Hydrostatic Drive CABIN (43x16.00-20) 1645 kg (3627 lbs)

Speed Chart

Gear Drive

Range shift	Gear shift	Tire size	Speed : miles(km/h)	
			F	R
L	1	Industrial tires (Front/Rear) 28x8.50-15/43x16.00-20	1.1(1.7)	0.9(1.5)
	2		1.5(2.4)	1.3(2.1)
	3		2.2(3.6)	1.9(3.1)
	4		3.4(5.5)	2.9(4.7)
H	1		3.9(6.2)	3.4(5.4)
	2		5.5(8.8)	4.7(7.6)
	3		8.3(13.3)	7.1(11.5)
	4		12.6(20.2)	10.8(17.4)
MAX			13.6(21.9)	11.7(18.9)

Hydrostatic Drive

Range shift	Tire size	F	R
L	Industrial tires (Front/Rear) 28x8.50-15/43x16.00-20	0-3.3(5.8)	0-1.6(2.6)
M		0-6.0(9.6)	0-3.0(4.8)
H		0-13.7(22.0)	0-6.8(11.0)
MAX		0-14.8(23.8)	0-7.4(11.9)

INSTRUMENTS AND INDICATORS

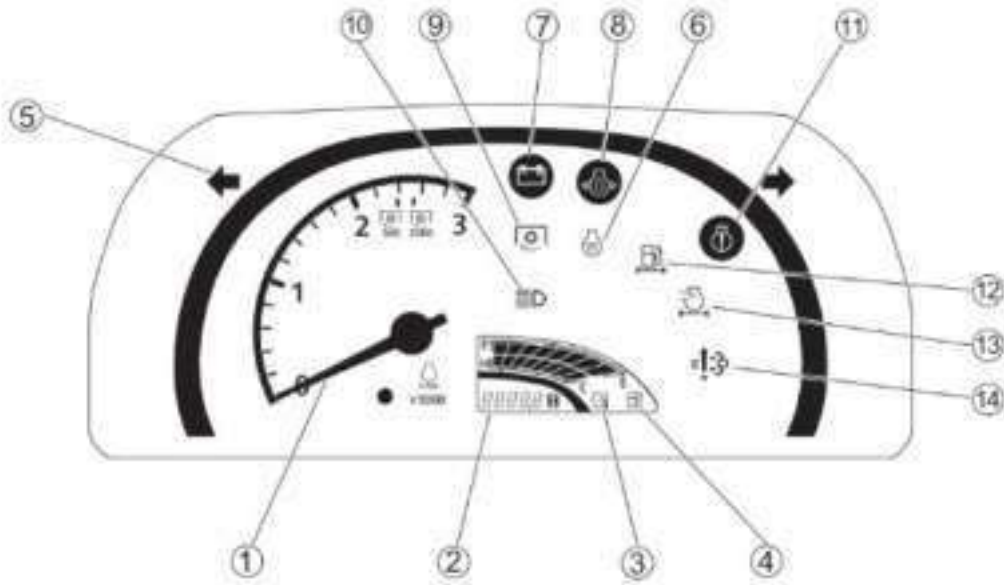

1.TACHOMETER

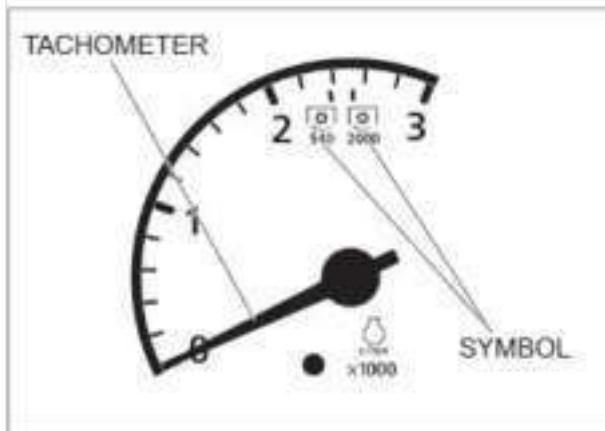

The tachometer shows the engine speed in revolutions per minute (r/min). A symbol on the face indicates the correct Power Take Off (PTO) operating speed.

The tachometer displays "Engine rotational speed / minute" (r/min) .

The symbol of the shape of the cogwheel directs the speed that uses appropriate PTO.

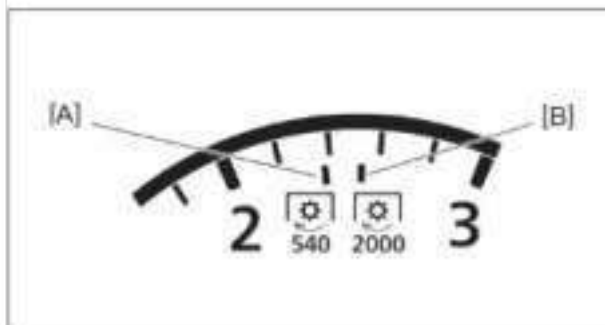

White line [A] shows the 540 rpm of the Rear PTO speed.

White line [B] shows the 2000 rpm of the MID PTO speed.

2. HOUR METER



The hour meter displays the engine driving time.

3. ENGINE COOLANT TEMPERATURE GAUGE

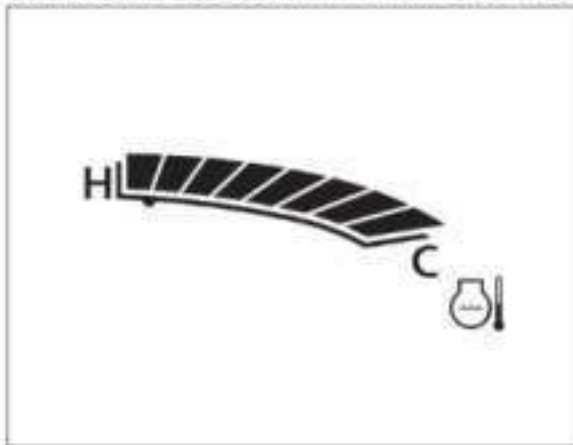

The gauge indicates the coolant temperature when the starter key switch is in ON position. If the engine overheats, the gauge turns the up side into "H" position area. In this case, stop the engine immediately and check for the cause.

4. FUEL GAUGE

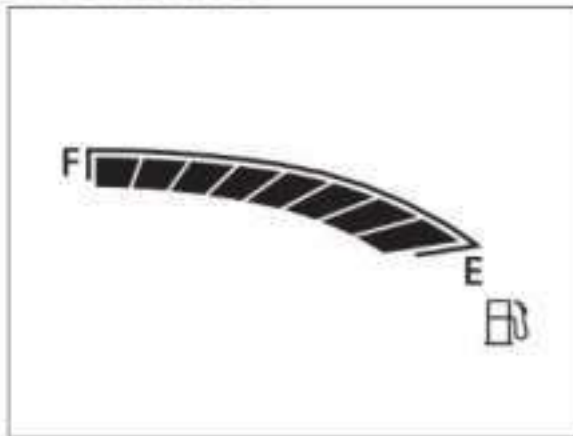

The gauge shows how much fuel is in the tank.

The lower symbol indicates empty and the upper symbol indicates full.

5. TURN SIGNAL INDICATORS

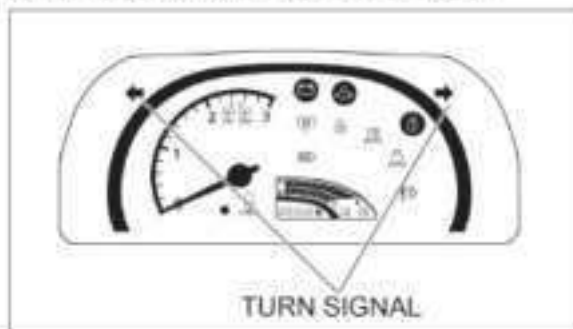

The LH indicator on the TACHOMETER will operate when the turn signal switch is turned to the left. The RH indicator will operate when the switch is turned to the right.

Both indicators will operate ON and OFF when hazard switch is pushed down.

INSTRUMENT/CONTROLS

6. ENGINE ELECTRICAL HEAT INDICATOR



This indicator shows engine low temperature start aid system is activated. (electrically heats the engine)

7. CHARGE INDICATOR



The charge indicator shows the battery is being discharged. If the lamp illuminates during operation, stop the engine and check for the cause.

8. ENGINE OIL PRESSURE INDICATOR



The engine oil pressure indicator shows low engine oil pressure. If the engine oil pressure drops below its normal pressure, the engine oil pressure indicator will turn on. Shut off the engine immediately. Check for the cause.

9. INDEPENDENT PTO CLUTCH INDICATOR (Gear Drive Only)



This signal indicates the INDEPENDENT PTO CLUTCH is ON or OFF.

10. HIGH BEAM INDICATOR



This signal indicates the head light high beam is ON or OFF. The INDICATOR illuminates when the head light is on high beam position.

11. ENGINE SYSTEM FAILURE OR MALFUNCTION INDICATOR

This signal indicates the engine system has failure or malfunction. If the lamp illuminates, shut off the engine, and then restart the engine. After restart the engine, if the lamp still illuminates, please contact dealer.

12. FUEL MAIN - FILTER INDICATOR

The fuel main-filter indicator shows water collects in fuel main-filter. If the lamp illuminates, drain off the water from fuel main-filter.

13. AIR CLEANER CLOGGING INDICATOR

The air cleaner clogging indicator shows air cleaner is clogged. If the lamp illuminates, check and clean air cleaner.

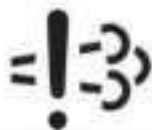
14. ENGINE EMISSION SYSTEM FAILURE OR MALFUNCTION INDICATOR

This signal indicates the engine emission control device has failure or malfunction. If the lamp illuminates, shut off the engine immediately and please contact dealer.

OPERATING CONTROLS

Control Switches

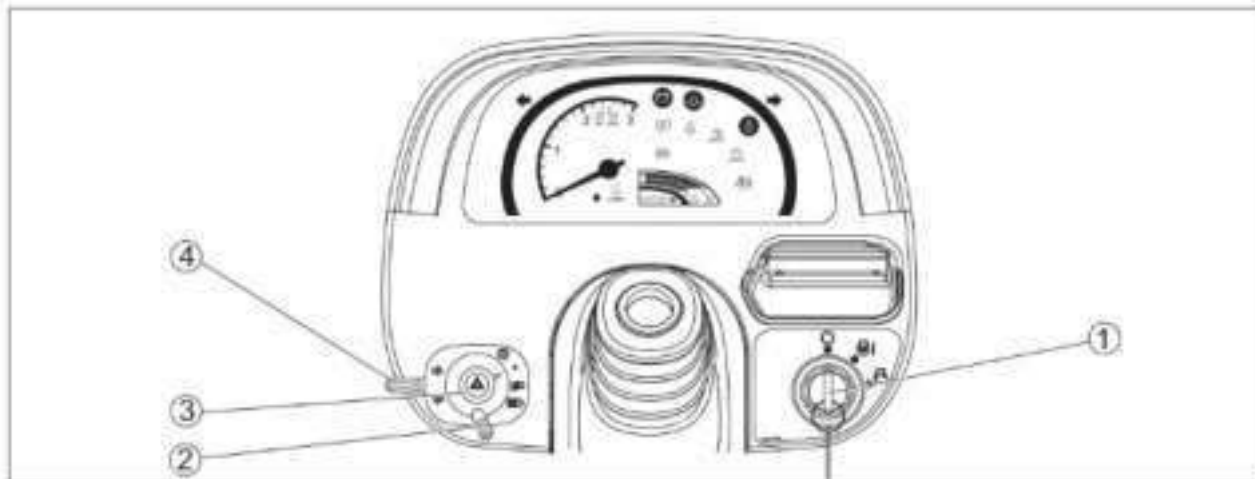

1. STARTER KEY SWITCH (See page 132 for CABIN type)

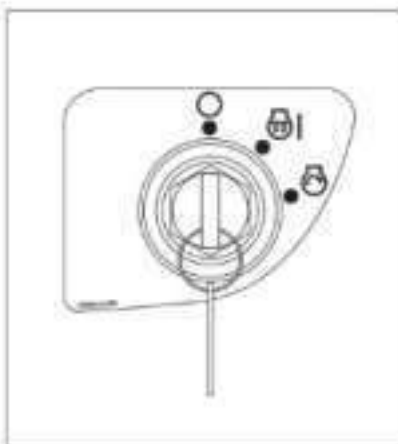

The starter key switch can be removed in the OFF position. Three switch positions are as follows:



Position (OFF)

Engine and all lamps except the turn signal and flasher lamps are turned off.



Position (HEAT) & (ON)

First position clockwise from OFF. In this position (Engine not running) electrically heats the engine (if needed). The charge indicator, oil pressure indicator, engine system failure or malfunction indicator, engine emission system failure or malfunction indicator and instruments panel lighting will illuminate.

The fuel gauge and temperature gauge will show correct values.



Position (START)

Turn the key fully clockwise against the force of the spring in the switch. The starter motor will turn the engine. Release the key immediately when the engine starts.

NOTE: To prevent operation by persons not authorized and the possible discharge of the battery, remove the starter key when you leave the tractor.

IMPORTANT: Do not keep the starter key switch in the ON position for a long time when the tractor is not operating.

2. LAMP SWITCH



Three position switch as follows:

ALL lamps are OFF. (Turn signal and flasher lamps can be turned on.)



First position clockwise illuminates head lamps and rear red lamp.



Second position is for head lamp high beam.



3. HAZARD SWITCH



To flash the Flasher Lamps whenever the tractor is operated or traveling on roads:



4. TURN SIGNAL SWITCH



To indicate that you are going to turn the tractor to the RIGHT, move the turn signal switch to right . To indicate that you are going to turn the tractor to the LEFT, move the turn signal switch to left . Center position is OFF.

INSTRUMENT/CONTROLS

Control Levers and Pedals (Gear Drive)

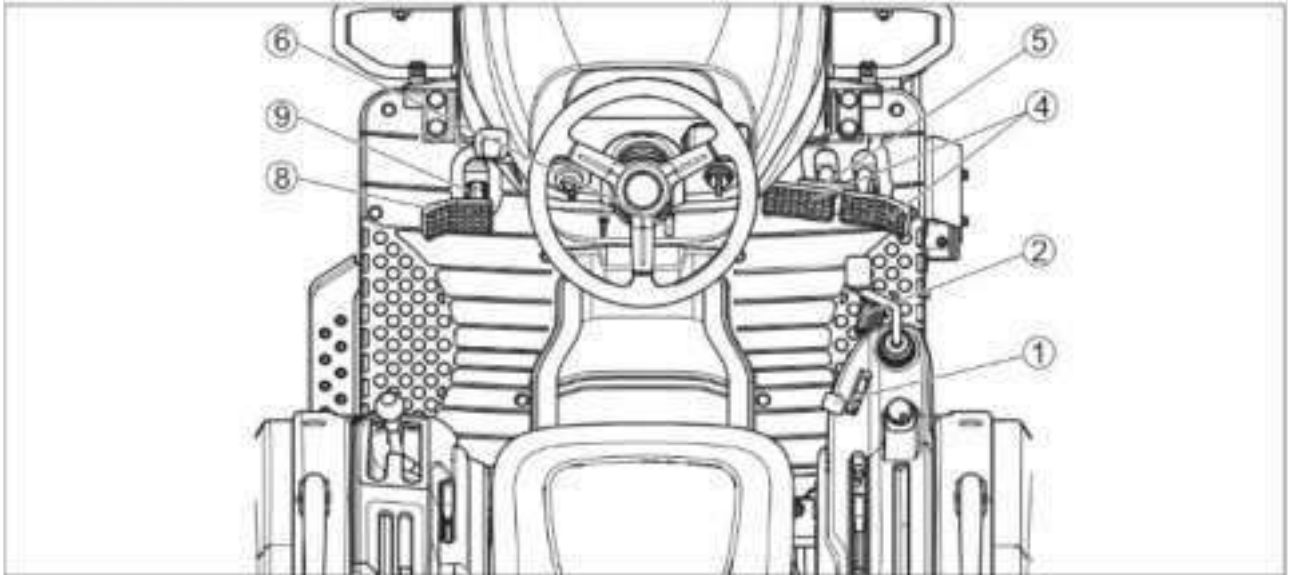

(Hydrostatic Drive)

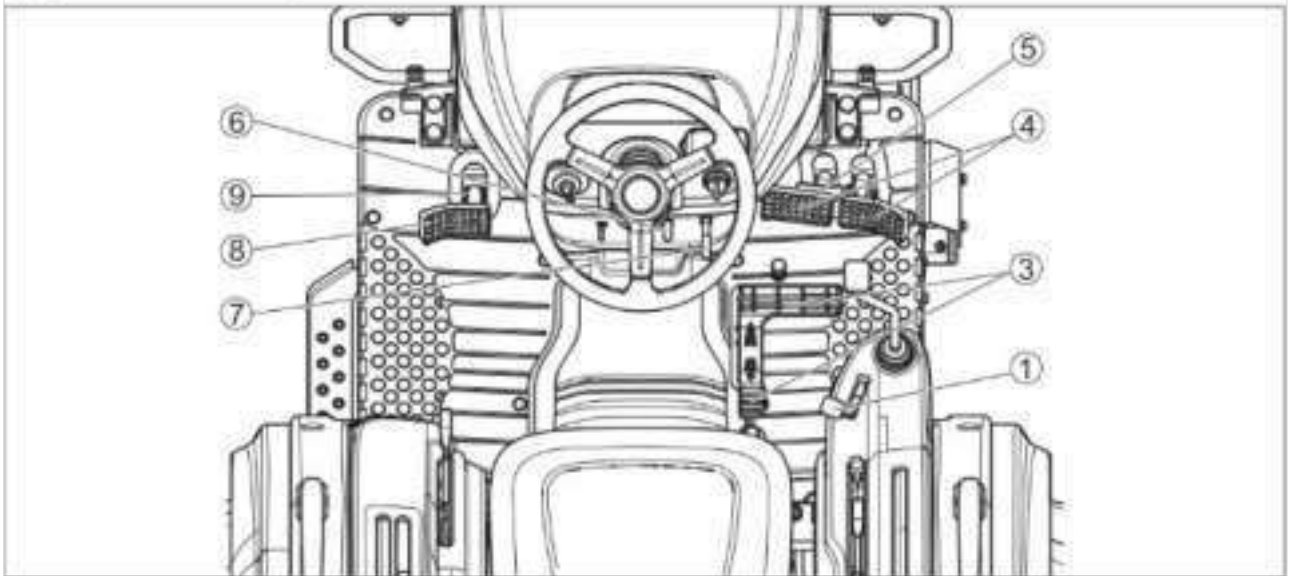

1. ENGINE SPEED CONTROL LEVER

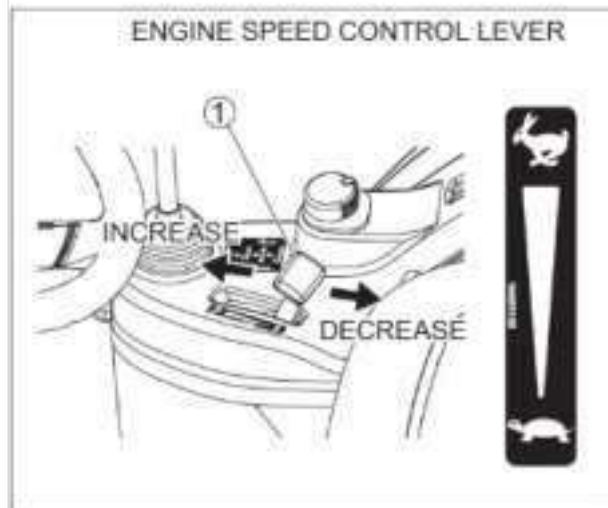

Push the engine speed control lever forward to increase the engine speed. Pull the engine speed control lever to the rearward to decrease the engine speed.

2. ACCELERATOR PEDAL (Gear Drive Only)

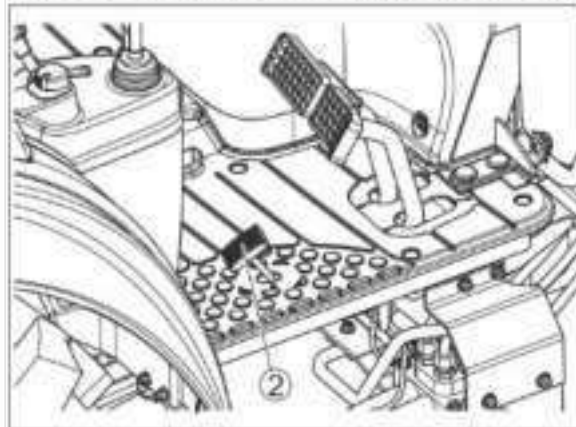

Use this pedal when operating the tractor on the road. Push the pedal down to increase engine speed.

NOTE: The engine speed control lever must be set to give the slowest engine speed when the throttle pedal is used.

INSTRUMENT/CONTROLS

3. SPEED RATIO CONTROL PEDAL (Hydrostatic Drive Only)

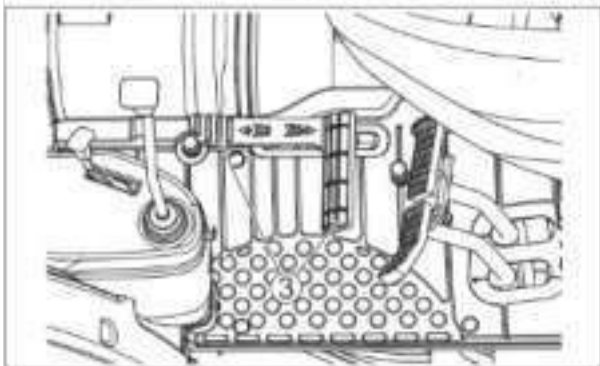

The control pedal is centralized to the neutral position by spring load. Push down on the front pedal to increase forward speed. Push down on the rear pedal to increase reverse speed.

4. BRAKE PEDALS

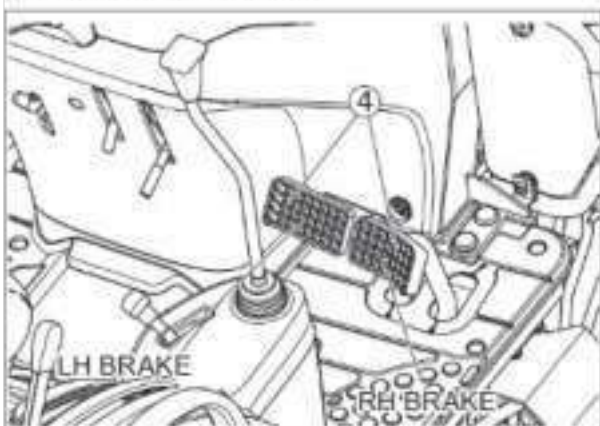

The pedals when locked together, provides braking to both rear wheels for stopping the tractor. When the brake pedals are unlocked, the pedals are used for individual braking of the rear wheels to aid in turning the tractor in soft soil conditions.

Push the RH brake pedal down to slow or stop the RH rear tractor wheel, push the LH brake pedal down to slow or stop the LH rear wheel. The tractor will turn in the direction of the wheel that is slowed or stopped.

5. BRAKE PEDAL LOCK

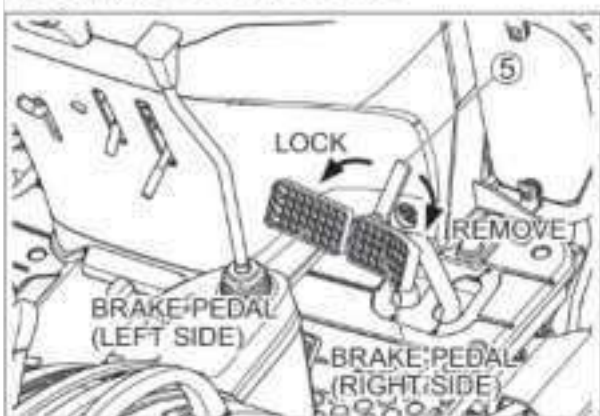

The brake pedal lock is located at the brake pedal arms and is used to lock the two brake pedals together so that both brakes are applied.



CAUTION: Brake pedals must be locked together for road travel. This will insure uniform brake application and maximum stopping ability.



WARNING: Extra weight and bad traction conditions such as mud or ice increase your stopping distance. Remember that liquid in the tires, weight on the machine or wheels, tank filled with fertilizer, herbicides or insecticides – all these add weight and increase the distance you need in which to stop.

6. PARK BRAKE LEVER

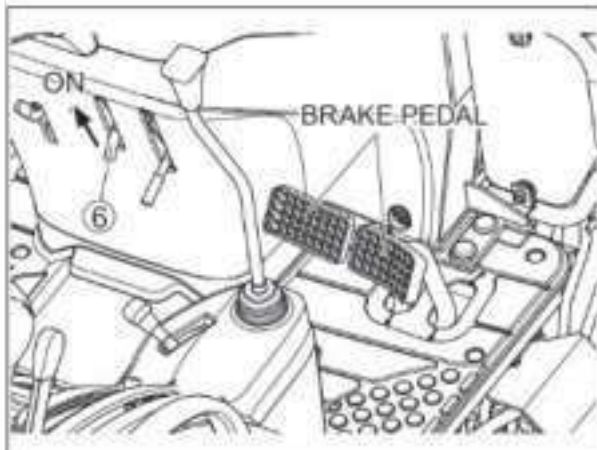

7. SPEED LOCK LEVER (Hydrostatic Drive Only)

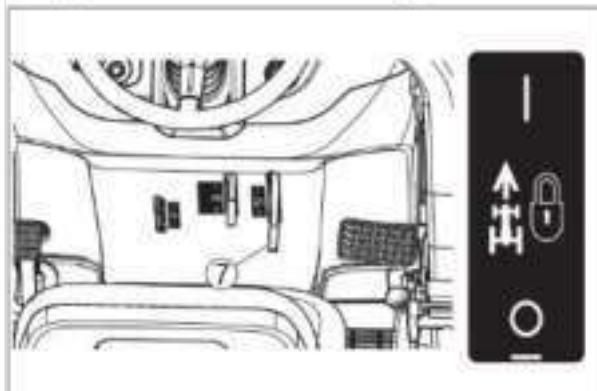

1. The park brake must be on to prevent movement of the tractor during stationary power takeoff work or when the tractor is parked. To engage the park brake, lock the brake pedals together, push down on the brake pedals and move the park brake lever upward. Push the brake pedal down to release the park brake.

2. Before getting off the tractor, disengage the PTO, lower all implements to the ground, place all control levers in their neutral positions, set the parking brake, stop the engine and remove the key.

3. If it is necessary to park on an incline, be sure to check the wheels to prevent accidental rolling of the machine.

(Hydrostatic Drive)

It is free on engine brake with the range lever engaged, be sure set the parking brake.

To keep a constant forward travel speed, move the lever fully upward, while holding the speed ratio control pedal at the desired speed. It does not work in reverse.

INSTRUMENT/CONTROLS

8. CLUTCH PEDAL

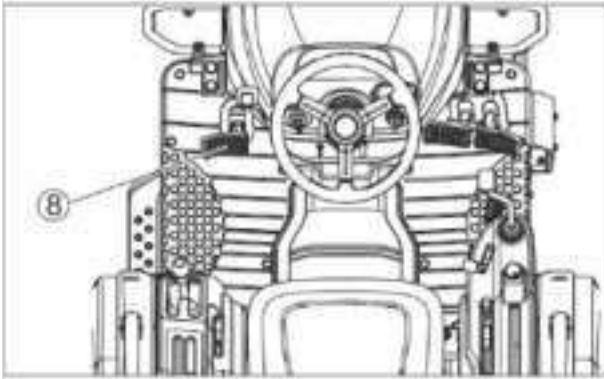

The clutch must be disengaged when starting the engine, stopping the tractor, storing the tractor and operating the following levers, gear shift lever, range shift lever rear PTO lever, MID PTO lever, MFD lever, shuttle shift lever.

9. CLUTCH LOCK LATCH

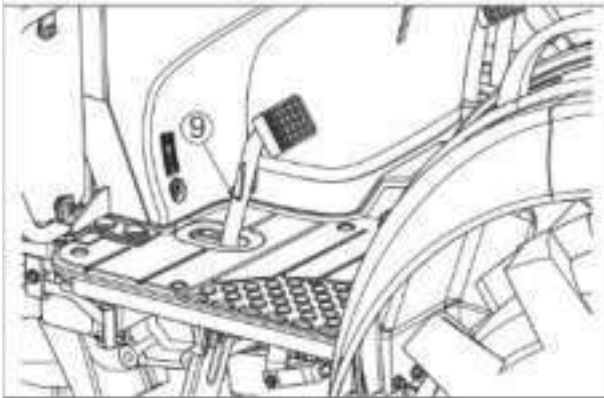

For long term storage, lock the clutch pedal in the disengaged position. This will prevent the clutch disc from sticking to the engine flywheel.

Control Levers
(Gear Drive)

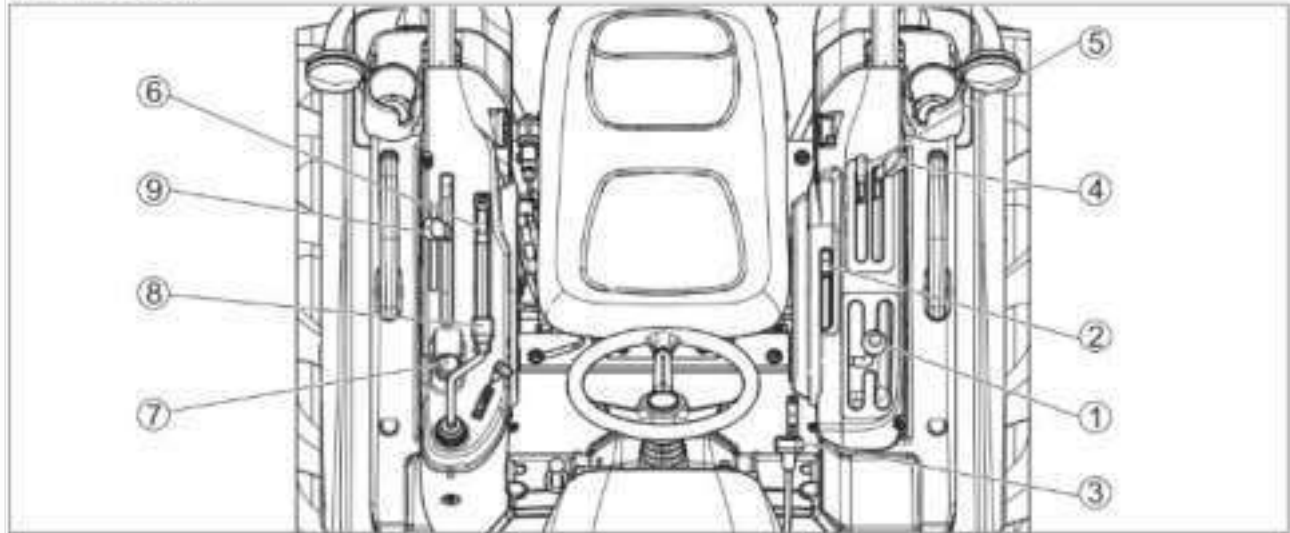

(Hydrostatic Drive)

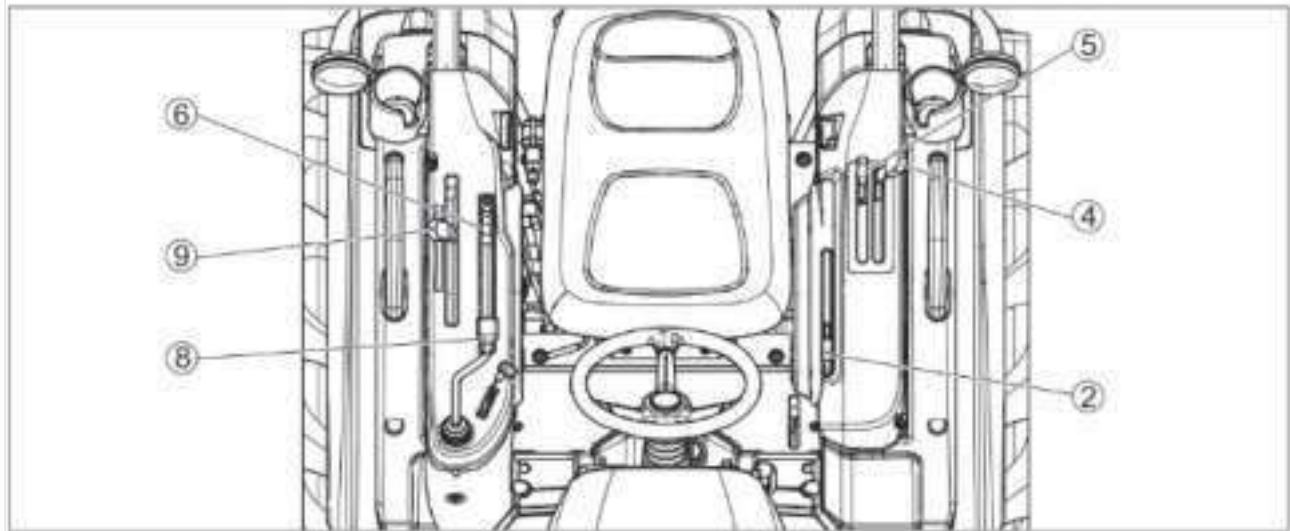

1. GEAR SHIFT LEVER (Gear Drive Only)

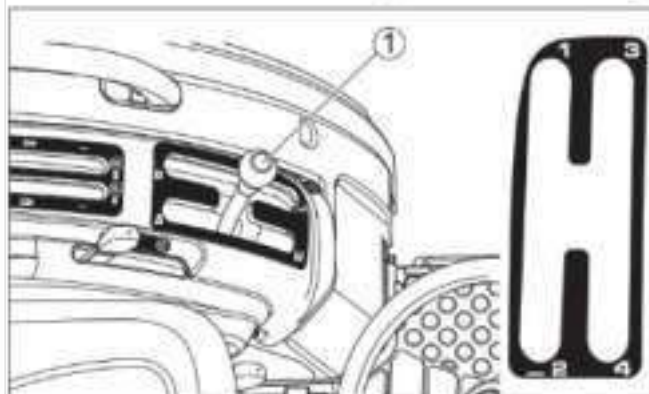

The gear shift lever is used to shift the transmission gears into any of four speeds.

INSTRUMENT/CONTROLS

2. RANGE SHIFT LEVER

(Gear Drive)

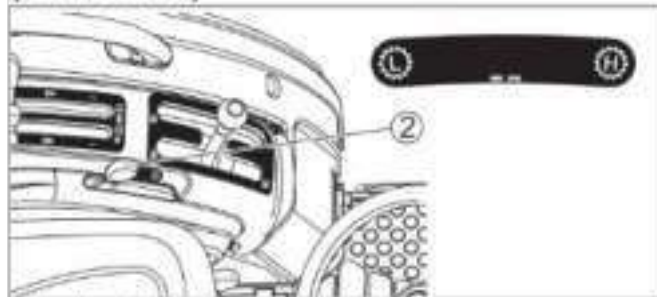

Move the range shift lever forward to place the transmission in H range. Move the lever rearward to place the transmission in L range.

(Hydrostatic Drive)

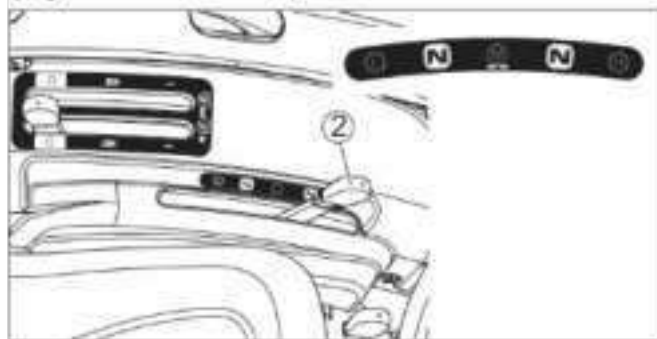

Move the range shift lever forward to place the transmission in H range. Move the lever to the rearward to place the transmission in M or L range. The center position between M and or Hand M places the transmission in N.

NOTE: Be sure the range shift lever is in N (Engine start) position when starting the engine.

3. SHUTTLE SHIFT LEVER (Gear Drive Only)

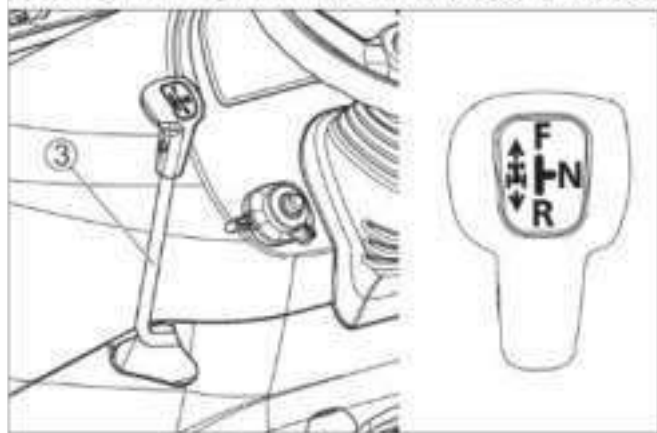

The shuttle shift lever is used to shift the transmission gear into forward or reverse position. Move the shuttle shift lever forward (F position) to move forward. Move the shuttle shift lever rearward (R position) to move reverse. The center position between F and R places the transmission in N position. (Neutral)

NOTE: Be sure the shuttle shift lever is in N (Engine start) position when starting the engine.

4. REAR PTO CONTROL LEVER

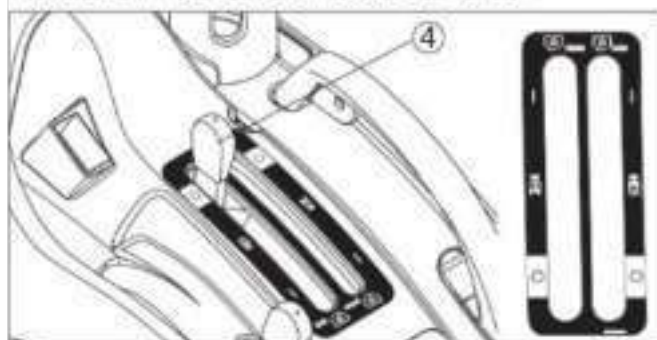

Move the lever forward to engage the REAR PTO. Move the lever rearward to disengage the Rear PTO.

NOTE: Be sure the Rear PTO control lever is in OFF position when starting the engine.

5. MID PTO CONTROL LEVER (If Equipped)

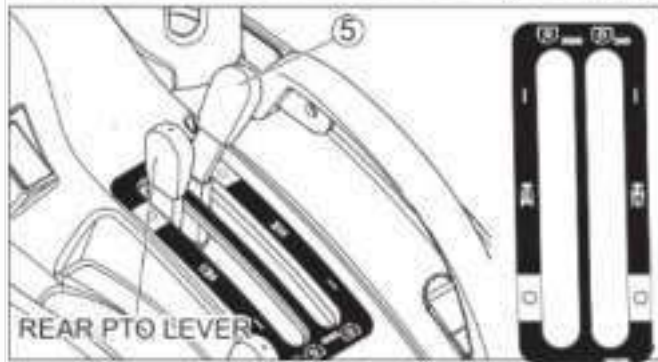

Move the lever forward to engage the Mid PTO. Move the lever rearward to disengage the Mid PTO.

NOTE: Be sure the Mid PTO control lever is in OFF position when starting the engine.

NOTE:

1. The Rear and Mid PTO shaft can be operated at the same time.
2. When not using the Mid PTO shaft, cover the shaft with the Mid PTO cover.

6. HITCH CONTROL LEVER

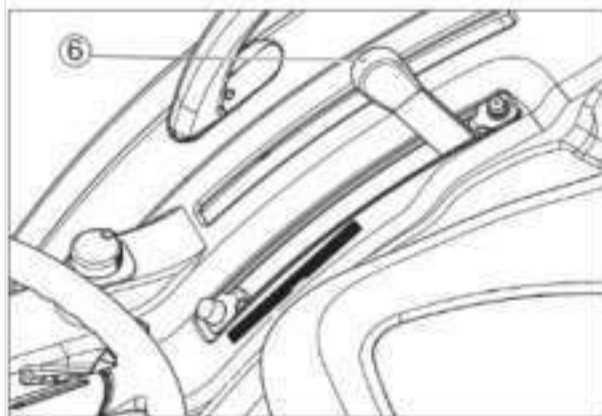

Use this lever to control the position of the hitch. Move the lever forward to lower the Three point hitch. Move the lever to the rearward to raise the Three point hitch.



7. PTO SWITCH (Gear Drive Only)

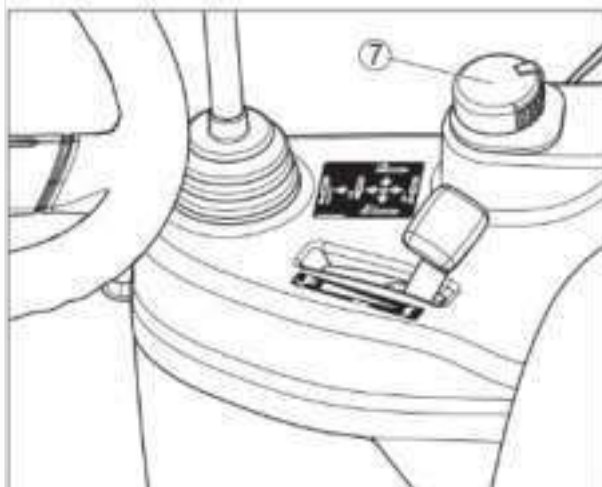

PTO switch is used to engage or disengage the Independent PTO clutch. Turn right PTO switch to engage the PTO clutch. (turning the PTO shaft) Push the PTO switch to disengage the PTO clutch. (stop the turning of PTO shaft)

PTO indicator lamp in the meter panel is illuminating when PTO is in ON position.

PTO indicator lamp is not illuminating when PTO is in OFF position.



NOTE: Be sure the PTO switch is in OFF position when starting the engine.

INSTRUMENT/CONTROLS

8. LOADER VALVE JOYSTICK

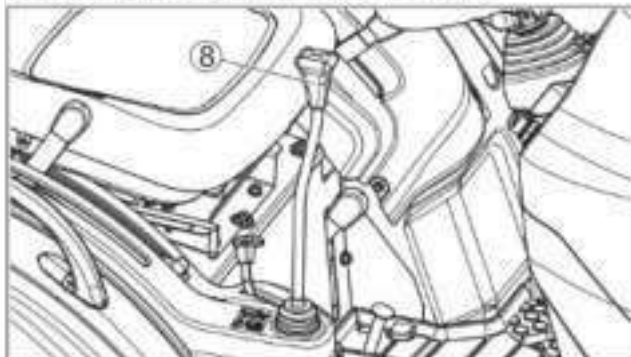

Joystick is utilized to control cylinder connected to port of loader valve.

9. REMOTE HYDRAULIC CONTROL LEVER WITH FLOAT POSITION (If Equipped)

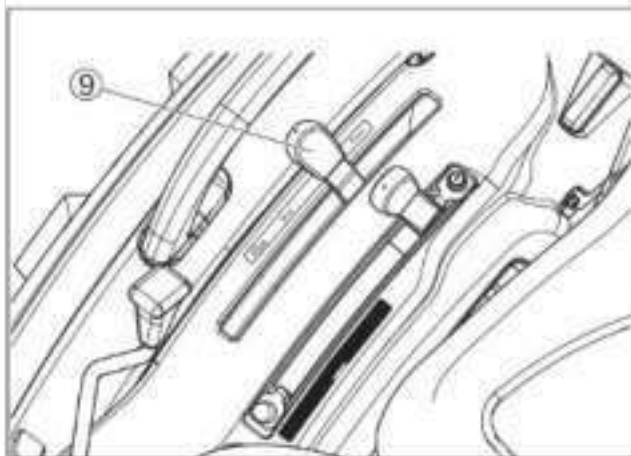

A double acting remote control valve is available for your tractor. The remote hydraulic control lever which operates the remote control valve is located on the RH side fender. See "remote hydraulic control" in this manual for more information.

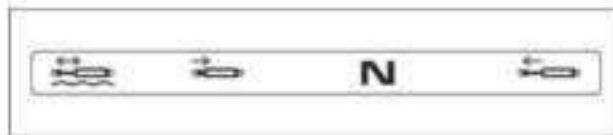

Control Levers and Pedals
(Gear Drive)

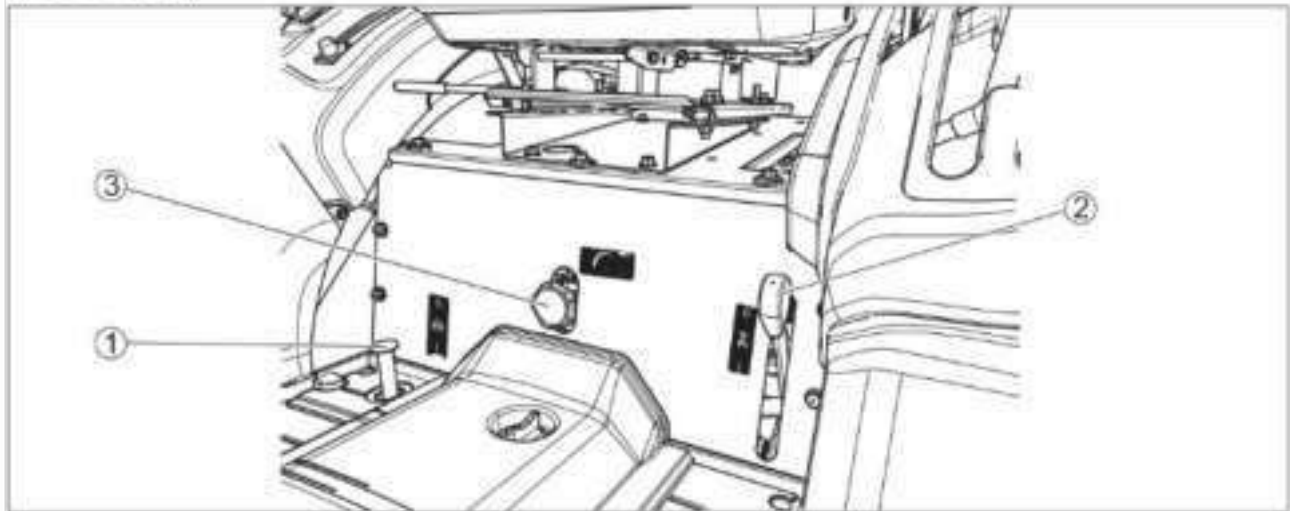

(Hydrostatic Drive)

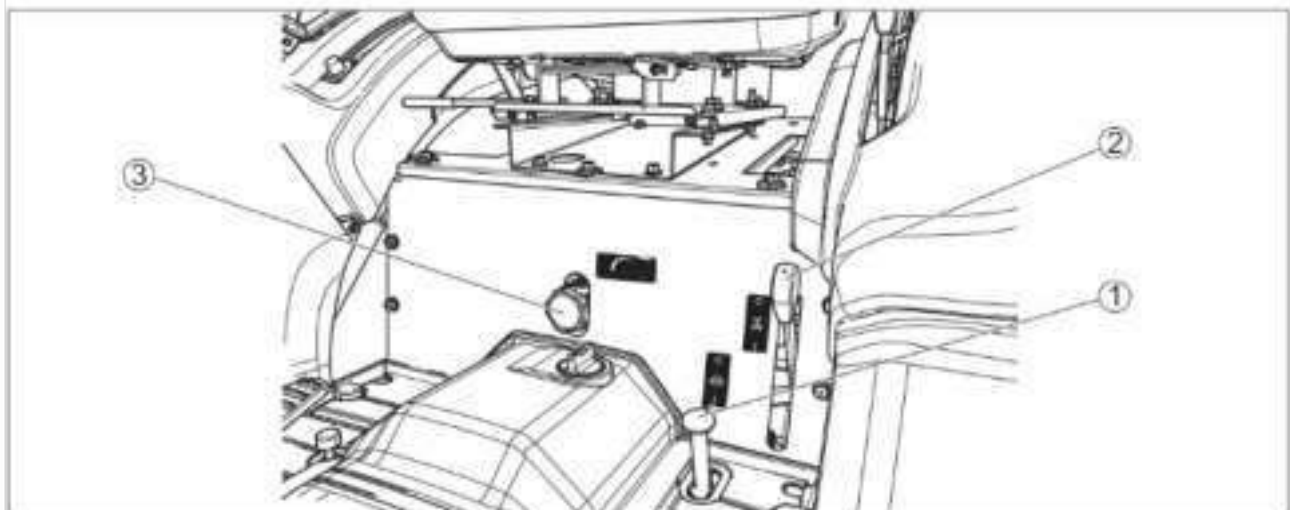

1. DIFFERENTIAL LOCK PEDAL

Push the pedal down to engage the differential lock. A spring inside of the differential lock pushes it out of engagement when pedal is released.

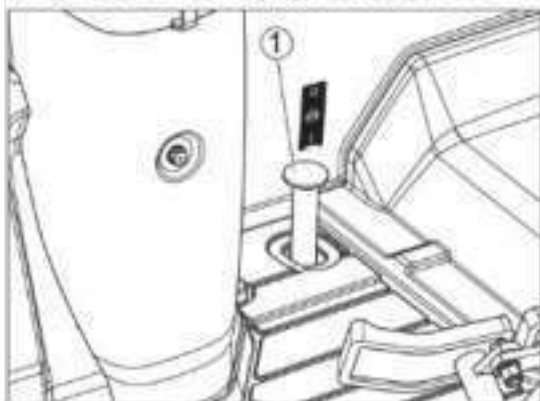

GEAR DRIVE



HYDROSTATIC DRIVE

INSTRUMENT/CONTROLS

NOTE: When engaging the differential lock, push the clutch pedal down or bring speed ratio control pedal to Neutral, to stop the wheels that are rotating, then push the differential lock pedal. Do not operate the differential lock pedal while the wheels are rotating.



Do not drive on roads, or at high speed anywhere, with the differential lock engaged. Difficult steering will occur, and can result in an accident. In field operation, use the differential lock for traction improvement, but release for turning at row ends.

2. MFD CONTROL LEVER

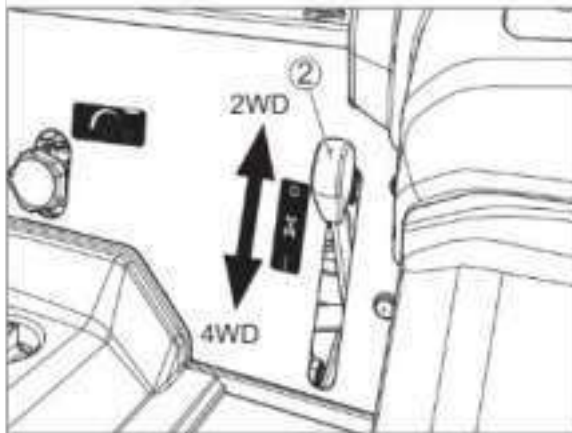

To engage the MFD (Mechanical Front Drive), move the MFD control lever upward. Move the lever downward to disengage MFD (drive to the rear wheels only).

IMPORTANT: The clutch pedal must be pushed down to operate the MFD lever.

3. HYDRAULIC FLOW CONTROL KNOB

Use the hydraulic flow control knob to adjust the hitch lowering speed. Adjust the lowering speed to provide smooth operation of the hitch with the implement being used. Turn the knob fully clockwise to lock the hitch in position. See Hitch Lowering Speed Adjustment in this manual for more information.

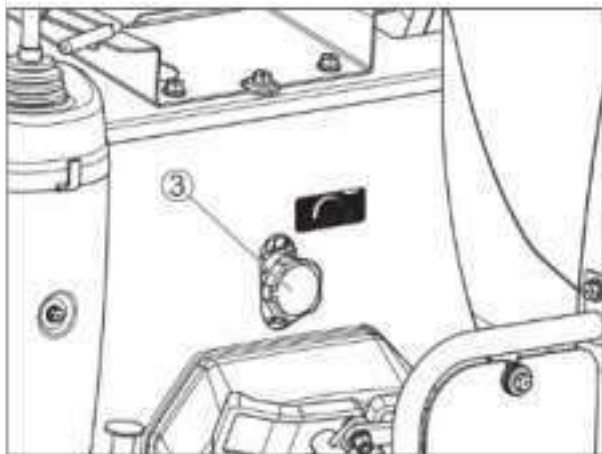

OPERATORS SEAT

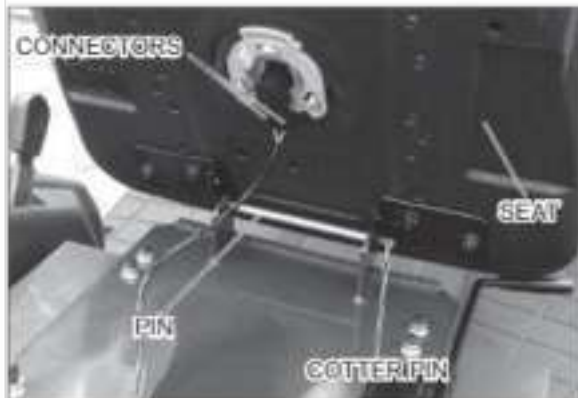

Install the operator's seat with the pin and secure it with the cotter pin.
Connect the connectors.

IMPORTANT: Check the switch as the following procedure after having installed the standard seat.

Checking the switch

- (1) Sit on the operator's seat
- (2) Apply the parking brake.
- (3) Shift the all operating control lever to "N" or "OFF".
- (4) Depress the clutch pedal.
- (5) Start the engine.
- (6) Shift the Mid PTO lever to "ON". (If Mid PTO equipped)
- (7) Leave the operator's seat.
- (8) Make sure the engine must shut off. In case the Mid PTO is disengaged, the engine will remain running if you stand up.

NOTE: If you leave the seat when the Mid PTO is engaged, safety system will automatically shut down the engine.

While engine is running, if you leave a seat, engine will shut off after one (1) second.



WARNING: Do not change the seat bracket position but maintain the seat bracket position as is. There is a possibility of serious injury or death due to altering the seat bracket position.

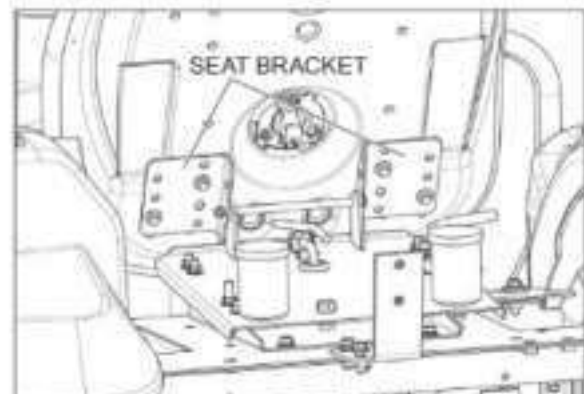

INSTRUMENT/CONTROLS

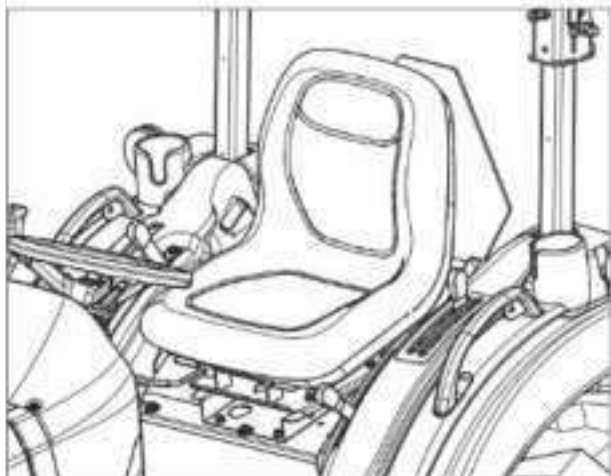

The seat can be adjusted in 5 fore/aft position by the lever located under the RH side of the seat.

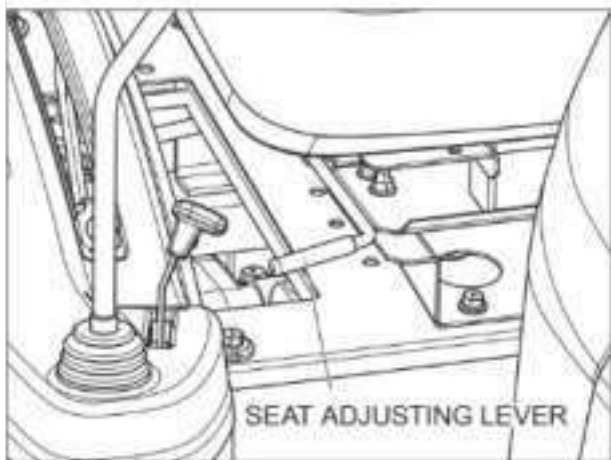

The seat is adjustable fore and aft by moving a lever.

1. Move the lever upward.
2. Move the seat rearward or forward to the required position then release the lever.
3. Push the seat rearward to make sure that the lock is engaged.

STEERING COLUMN TILT

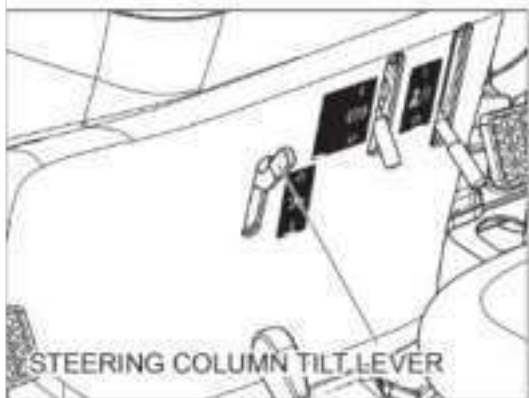

The steering wheel angle can be adjusted in three positions by the lever located under the steering column.

To adjust the position of the steering wheel, use following procedure.

1. Move the lever fully downward to disengage the latch from the column.
2. Move the steering wheel rearward or forward to the required position, then return the lever upward to lock the steering column.
3. Make sure that the lock is engaged.

BEFORE STARTING THE ENGINE

Before starting your tractor for the first time and before each operating period after that, make these checks:

1. Make sure all persons who operate or do maintenance on the tractor understand that clean fuel is important.
2. Check all lubrication fittings for grease as given in the Lubrication Chart.
3. Check the oil level in the engine crankcase. Check the oil level in the transmission.
4. Check the tractor fuel tank is filled with clean fuel that has the specifications given in this manual.

NOTE: Clean around the fuel tank cap before you remove cap.

5. Check the fuel system, cooling system and engine oil pan for leaks.
6. Check the fan belt is adjusted correctly.
7. Remove any water or sediment from the fuel filter cup.
8. Check the air pressure of the tires.
9. Make sure the PTO safety guard is installed.
10. Check the coolant level in the radiator and reservoir bottle. Add water and ethylene glycol coolant as needed.

OPERATING/INSTRUCTIONS

RUN – IN PROCEDURE

If run-in instructions for a new engine are not followed, you can cause damage to piston rings and cylinder walls.

LOAD

Never operate an engine immediately under full load. Allow the engine to warm up before operating it at full load. Run-in the engine carefully as shown in the table.

Period	Engine Speed Control Lever Position	Load
1st Hour	Fully advanced	Maintain engine speed 100 RPM above full load governed speed
2nd Through 5th Hour	Fully advanced	Full load governed speed with occasional short periods of lighter load

NO LOAD

Do not run the engine at idle speed. When not operating the engine with a load, you can keep the correct engine operating temperature if you run the engine at approximately 1500 RPM.

REAR WHEEL BOLTS

After the first 10 hours of operation, check the rear wheel bolts. Tighten all wheel bolts to the torque give in the Wheel Mounting Torques in this manual.(P77)

FRONT WHEEL BOLTS

After the first 10 hours of operation, check the front wheel bolts. Tighten the bolts to the torques shown in the Wheel Mounting Torques in this manual.(P77)

FRONT FRAME BOLTS

After the first 10 hours of operation, check the front frame bolts. Tighten the bolts to the torque shown below.

Front frame mounting torques

Size M14x35, 16Bolts ... 150–170 N·m (110–125Lbft)

LOWER LINK BRACKET BOLTS

After the first 10 hours of operation, check the Lower Link Bracket bolts.

Tighten the bolts to the correct tightening 39 to 44 N·m (29 to 33 Lbft)

NORMAL STARTING PROCEDURE

IMPORTANT: It is very important that enough lubricant reaches the engine parts before operating the engine at rated speed.



Operate controls only when seated in the operators seat.



Engine can start with transmission in gear when neutral or safety start switch is by-passed:

1. Do not connect across terminals on starter.
2. Attach a booster battery by connecting the positive terminal of the booster battery to the "positive terminal" provided or to the positive terminal of the machine battery. Connect the negative terminal of the booster battery to the chassis of the machine. Then use recommended starting procedures from operators seat.
3. When necessary, repair electrical system components promptly so that "jump starting" will not be attempted.

Machine run-away can cause injury or death to operator and bystanders.

STEP 1 (Gear Drive)

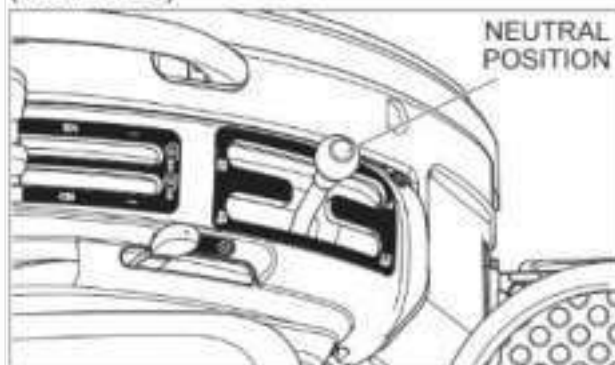

Put the gear shift lever in the Neutral position.

(Hydrostatic Drive)

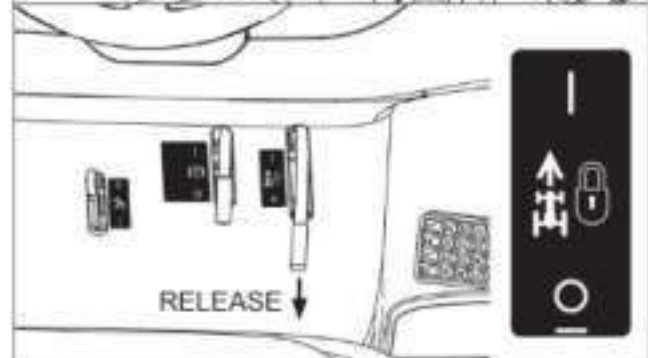
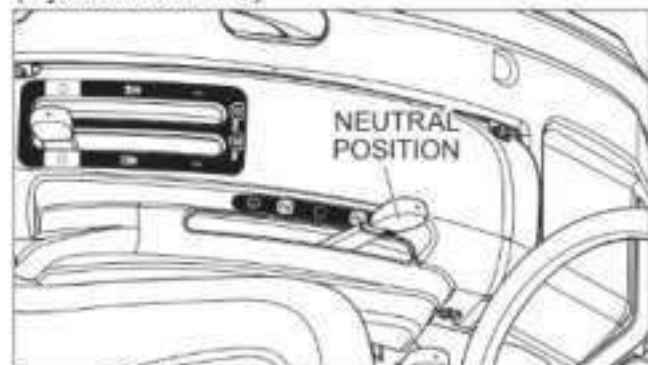

Put the range shift lever in the Neutral position and the Speed Lock Lever to be released.



Before starting the engine, be sure all operating controls are in neutral or park lock position. This will eliminate accidental movement of the machine or start up of power driven equipment.

OPERATING/INSTRUCTIONS

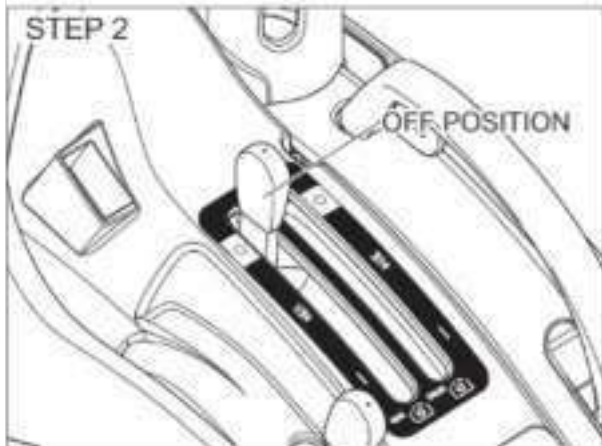

Put the REAR PTO and MID PTO control levers (If equipped) in the OFF (Engine start) position.

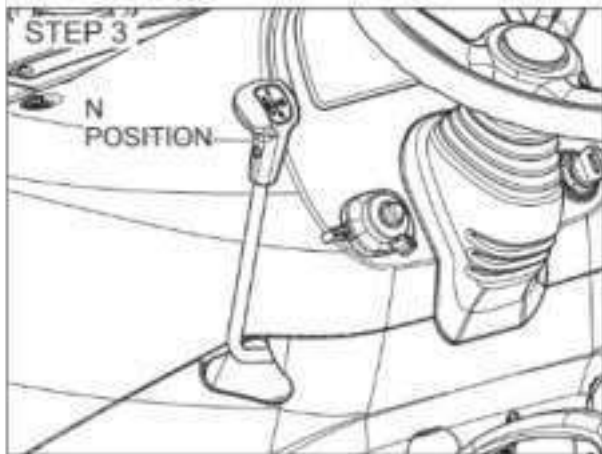

Put the SHUTTLE lever in the N (Engine start) slot (Gear Drive).

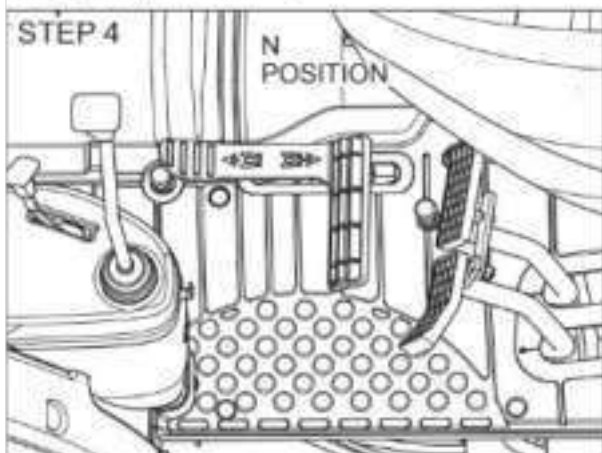

HST control pedal in the N position (Engine start) (Hydrostatic Drive)

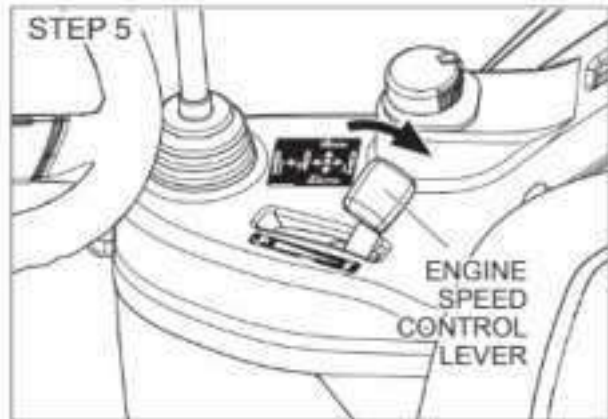

Put the engine speed control lever at the low speed position.

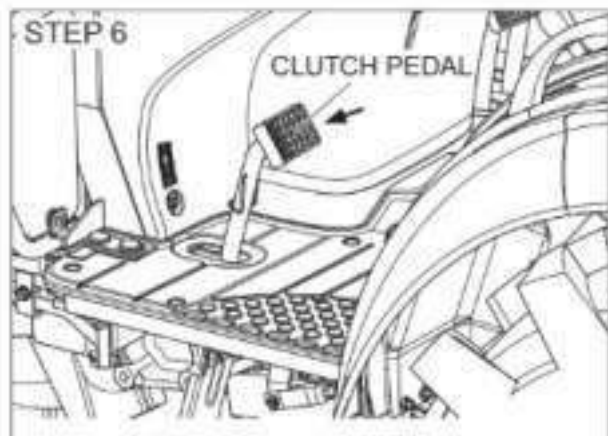

Push the clutch pedal down.

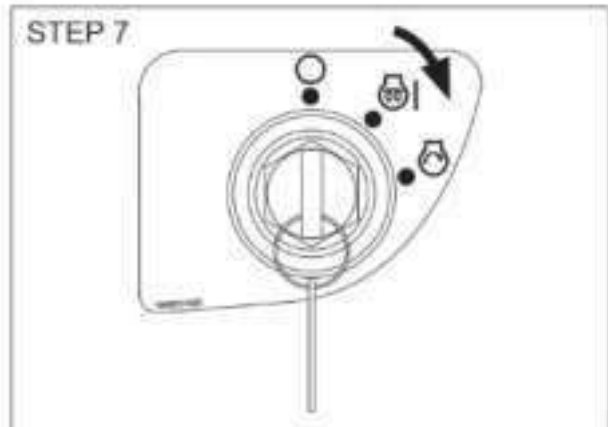

Turn the starter key switch to the heat & ON position.

Wait until the engine electrical heat indicator lamp is put out.

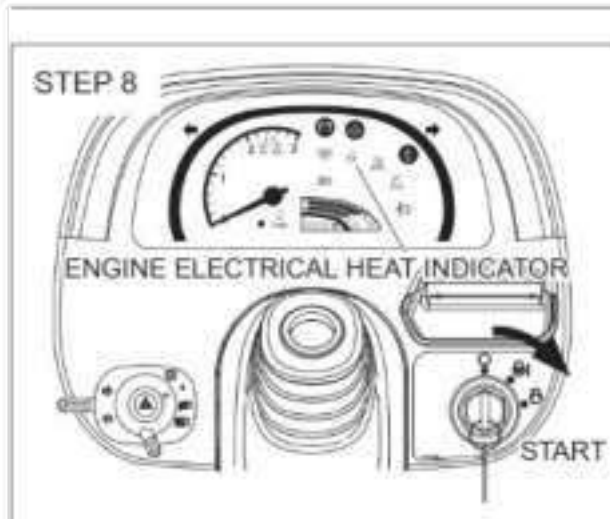

Turn key switch to start position until engine starts, but no more than 10 seconds, then release the key. Run engine for two minutes at 1500 RPM.

STEP 9

When the engine starts, check the oil pressure indicator, charge indicator, engine system failure or malfunction indicator and engine emission system failure or malfunction indicator, if the indicator stays on, stop the engine and find out what is wrong.

NOTE: If the oil pressure indicator stays on after the engine starts, stop the engine and check the oil level in the crankcase. Add oil if necessary. Start the engine, if the indicator is still on, do not operate the engine. Operating the engine without oil pressure will damage engine bearings and other engine parts. See your dealer.

IMPORTANT:

1. If the engine starts and then stops, wait for the starting motor to stop turning before you turn the key switch to START position again.
2. Do not use the starter motor for more than 10 seconds without stopping. Wait one minute between starts so the starter motor can cool.
3. If engine stops when operating with a load, immediately start the engine again to prevent overheating caused by stopping the flow of oil for cooling and lubrication.
4. If the charge indicator comes on during operation, determine and correct the cause to avoid complete discharge of the battery and possible damage to other components of the electrical system. See your Dealer.
5. If the coolant temperature indicator comes on, remove the load and allow the engine to run at 1500 rpm until the indicator goes out. If the indicator does not go out within one minute, stop the engine and determine the cause.
6. If engine system failure or malfunction indicator or engine emission system failure or malfunction indicator comes on during operation, stop the engine immediately. See your dealer.

OPERATING/INSTRUCTIONS

Starting Procedure for Hydrostatic Drive Tractors After Transporting on Truck or Flatcar.

IMPORTANT: Hydrostatic transmission can jump into gear without warning, if the fluid leaks out of the control system. This can occur due to vibration if the tractor is transported on a truck or rail car. It can also happen if the transmission is drained or if the tractor sit still for very long periods. If any of these have happened, start the tractor as follows:

1. Put the range shift lever into the N (Neutral) position and release the speed lock lever to permit the speed ratio control pedal to return to N (Neutral) position.
2. Lock the brake pedals together, press down on the brake pedals.
3. Push the engine speed control lever and start the engine. Set the engine speed to about 1000 RPM.
4. Slowly move the range shift lever to H range for high speed engagement.

If gear clash is obvious, the engine should be shut off immediately and the tractor unloaded by other means. Tow the tractor with the range shift lever in N (Neutral) to an area where the transmission can be checked by your Dealer. Refer to Towing the Tractor in this manual. (P51)

If there is no obvious gear clash, drive the tractor in the normal manner.

STOPPING THE ENGINE

IMPORTANT: When stopping the engine after operating under heavy load, run the engine at 1500 RPM for a short period of time. This will allow the engine temperature to decrease gradually.

STEP1

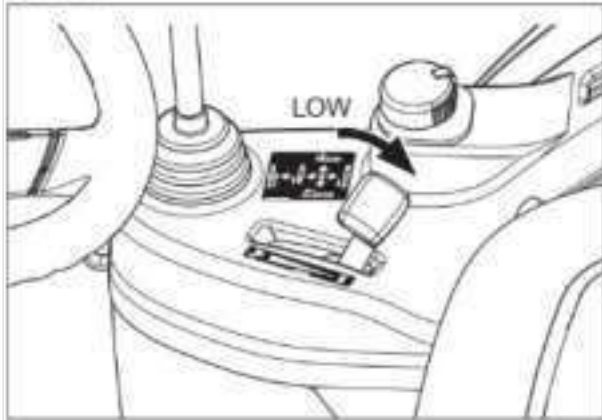

Move the engine speed control lever to run engine at low speed position for three to five minutes to decrease the temperature of engine.

STEP2

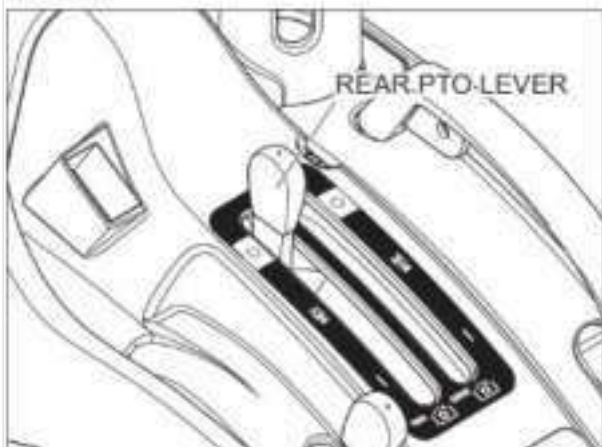

Put the REAR PTO control lever, MID PTO control lever (If equipped) and the range shift lever in the OFF or N (neutral) position.

STEP3

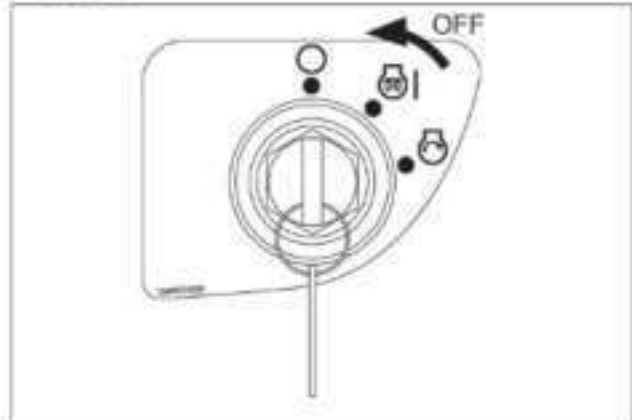

Turn key switch to OFF position.
Remove the key.

COLD TEMPERATURE OPERATION

To start and operate your tractor during cold ambient temperatures, use these procedures:

1. **BATTERY** – Must have a full charge.
2. **FUEL** – Must be clean and with no water.
3. **ENGINE OIL** – Must have the correct viscosity for the ambient temperature range.
4. **TRANSMISSION HYDRAULIC FLUID** – Use Hydraulic Transmission fluid.
5. **COOLING SYSTEM** – Must have ethylene glycol solution for protection.
6. **TIRES** – If there is liquid in the tires, the tires must have protection against temperatures below 0°C(32°F). See your Dealer.
7. **STOPPING THE ENGINE** – Run the engine at idle speed for a short period of time to permit the engine temperature to decrease before stopping.
8. **CONDENSATION IN FUEL TANK** – To prevent condensation in the fuel tank and water entering the fuel system, fill the fuel tank after each operating day.
9. **FUEL FILTER CUP** – During cold ambient temperatures, make sure you remove water from the fuel filter cup each day.

NOTE: Do not use ether as a cold temperature starting aid.

IMPORTANT: During cold ambient temperatures, never run the engine at low idle speed for long periods of time.

During cold ambient temperatures, the engine will not heat to or keep the rated operating temperature can cause damage to the engine. Use the following procedures to warm the engine and transmission oil, and to keep the correct operating temperature.

1. WARMING THE ENGINE AND TRANSMISSION.

- A. To heat the transmission oil to operating temperature, run the engine at 1500 RPM for more than five minutes.

IMPORTANT: Operating the tractor with cold transmission oil can cause rough tractor operation with possible injury to the operator.

2. KEEP THE ENGINE AT CORRECT OPERATING TEMPERATURE.

- A. Never run the engine below 1500 RPM.
- B. Put a cover in front of the grille to control the amount of air going through the radiator.

3. STOPPING THE ENGINE

- A. Run the engine at slow speed for a short period of time. This will permit the engine temperature to decrease gradually before stopping the engine.

OPERATING/INSTRUCTIONS

TOWING

When towing a tractor, follow these rules:

1. Never pull the tractor faster than a ground speed of 16 Km/h (10MPH).
2. Make sure all controls are in the N (neutral) or OFF position.
3. Because of a possible loss of steering and brakes when the tractor engine is not running, use only a rigid towing bar and safety chains to pull the tractor.



Make sure that the weight of a trailed vehicle that is not equipped with brakes, NEVER EXCEEDS the weight of the machine that is towing the vehicle. Stopping distance increases with increasing speed as the weight of the towed load increases, especially on hills and slopes.

HOW TO TRANSPORT TRACTOR

When you transport the tractor by truck or rail, follow these rules:

1. Hold the tractor with tie downs and block the wheels.
2. Gear Drive: Put the gear shift lever in 1 st position and put the rang shift lever in the L position and shuttle shift (over in F or R) position.
Hydrostatic Drive: Move the Speed Lock lever to OFF position and put the range shift lever in the L position.
3. Lock the brake pedals together, push the brake pedals down and move the park brake lever to engage the park brake .

GEAR DRIVE TRANSMISSION

The gear drive transmission has forward and a reverse gear section and a four-speed main shift gear section, and a two-speed range section. This arrangement gives eight forward and eight reverse speeds.

Transmission Operation

1. Push the clutch pedal and stop the tractor. Move the gear shift lever to the gear needed.
2. Move the range shift lever to the position needed, H, L (The tractor must be stopped before the range lever is operated.)
3. Move the shuttle lever to Forward or Reverse position.
4. Release the clutch pedal slowly.

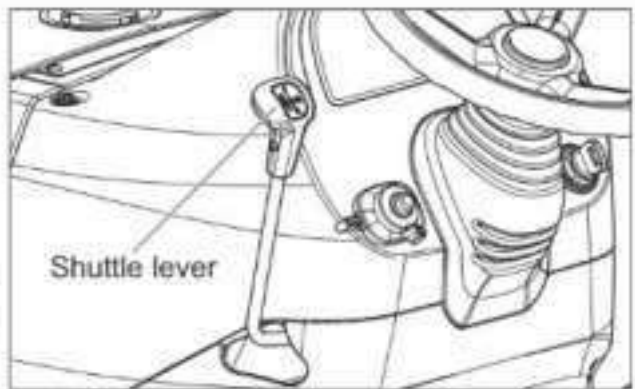
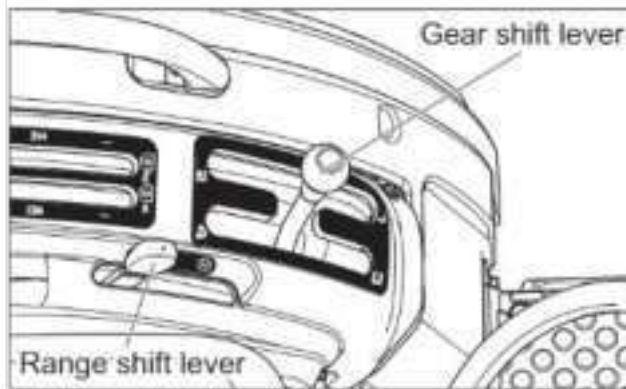

IMPORTANT: Before selecting a new range, push the clutch pedal and stop the tractor. Do not change range when the tractor is moving.

HYDROSTATIC DRIVE TRANSMISSION

The Hydrostatic drive transmission has a forward/reverse hydrostatic section and a three-speed range section. This arrangement gives three forward and three reverse speeds ranges.

Transmission Operation

1. Push the clutch pedal fully and stop the tractor. Move the range shift lever to the position needed, H, M or L.
2. Release the clutch pedal slowly.
3. Operate the speed ratio control pedal to move the tractor.
To shift from reverse to forward or from forward to reverse, reduce the speed and switch to depress the speed ratio control pedal one from the other.

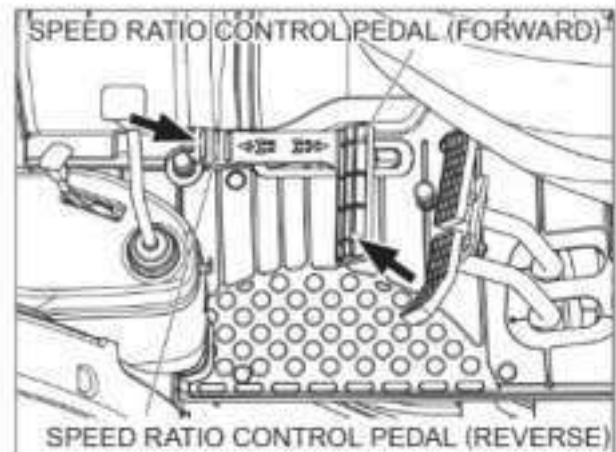
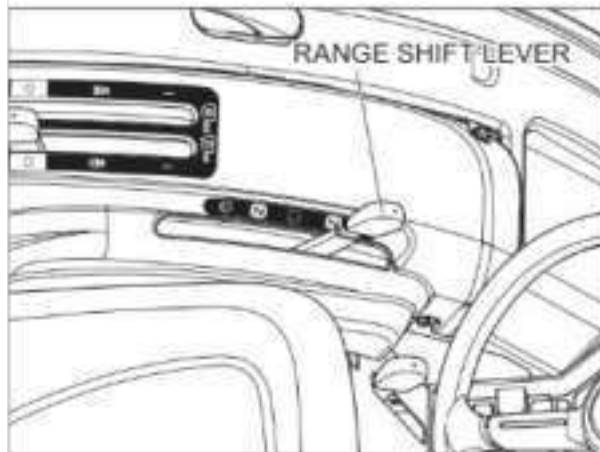

IMPORTANT: Before selecting a new range, stop the tractor and push the clutch pedal. Do not change range when the tractor is moving.



Travel speed should be such that complete control and machine stability is maintained at all times. Where possible, avoid operating near ditches, embankments and holes. Reduce speed when turning, crossing slopes, and on rough, slick, or muddy surfaces.

HYDROSTATIC SPEED LOCK LEVER (Hydrostatic Drive Only)

The speed ratio control pedal of hydrostatic drive has a speed lock lever.

This lever is used to keep a constant forward speed without controlling the pedal. It can not be used for reverse speed. The lever is located under the instrument panel.

Operate the speed lock lever as follows:

1. Determine forward speed as you need by pressing the speed ratio control pedal forward.
2. Move the lock lever upward to lock the position of the pedal. (It can keep the forward speed constant).
3. Remove your foot from the pedal.

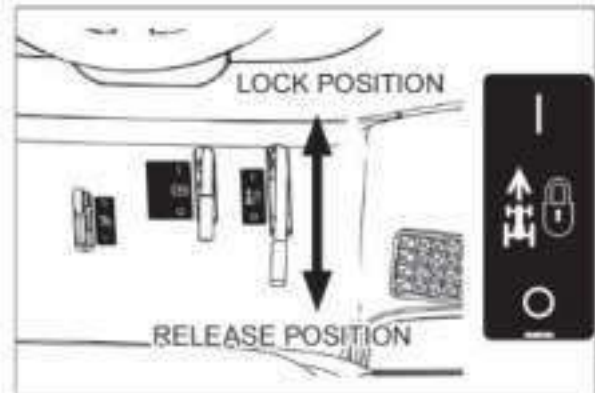

4. To release the lock, move the lock lever downward.

NOTE:

The speed ratio control pedal will return to neutral position and the tractor will stop if your foot is not on the pedal.

5. Increase of forward speed, speed ratio can be obtained to max. speed by pressing the pedal forward while the lock lever is in lock position.
However, decrease of forward speed ratio or change to reverse speed can not be obtained, while the lock lever is in lock position.
6. To decrease forward speed ratio or change to reverse speed, put your foot on the pedal first, then release the lock lever. Control speed ratio or direction with the foot pedal.

NOTE:

1. The lock lever can not be released by pressing the brake pedal.
2. The lock lever can not be released by pressing the hydrostatic speed ratio control pedal.
3. Make sure to keep the lock lever in the off position when starting the tractor.
4. Return the lock lever to the off position when stopping the tractor.

MECHANICAL FRONT DRIVE (4WD)

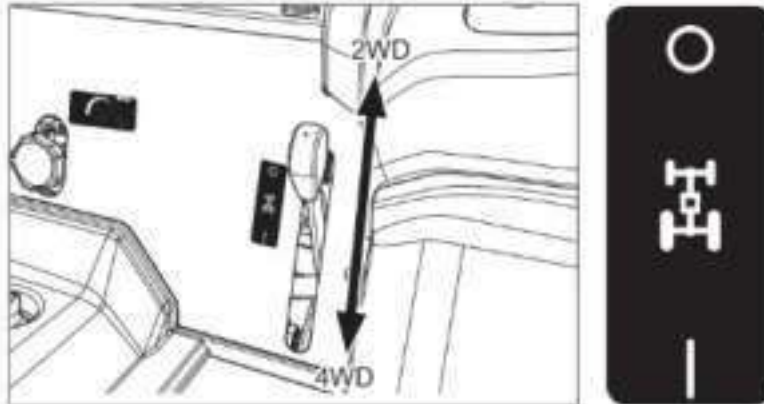

Use the 4WD to obtain improved traction in loose, sandy or wet soil conditions. 4WD will also give improved steering control and will reduce soil compaction. 4WD can be engaged or disengaged as needed by the 4WD control lever located on the LH side below the operators seat.

To engage the 4WD, press the clutch pedal down, stop the tractor and move the 4WD control lever down to the ON position.

IF THE 4WD IS DIFFICULT TO ENGAGE, DO THE FOLLOWING:

1. Push the clutch pedal.
2. Move the range shift lever to L range.
3. Release the clutch pedal slowly, move the tractor forward or rear ward small amount.
4. Move the 4WD control lever down until fully engaged with proper force.

To disengage the 4WD, push the clutch pedal, stop the tractor and move the 4WD control lever up to the OFF position.

IF THE 4WD IS DIFFICULT TO DISENGAGE, DO THE FOLLOWING:

1. Move the range shift lever to L range.
2. Slowly release and press the clutch pedal to move the tractor forward or rearward small amount.
3. Push the clutch pedal and stop the tractor.
4. Move there 4WD control lever up until completely disengaged.



Tractors equipped with mechanical front drive (MFD) have increased traction and can climb steeper slopes. Stay off slopes too steep for safe operation. To prevent rear overruns, back up steeper slopes.

DIFFERENTIAL LOCK

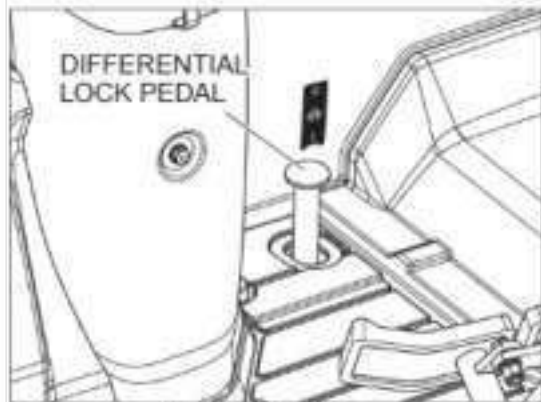

GEAR DRIVE

RIGHT SIDE of the transmission

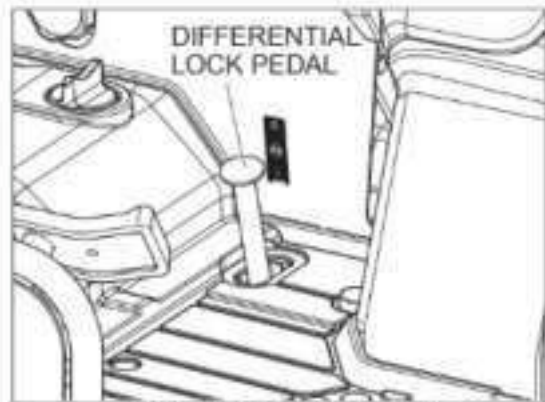

HYDROSTATIC DRIVE

LEFT SIDE of the transmission

Your tractor has a differential lock that will make both rear wheels turn at the same speed. The differential lock prevents loss of power when one wheel does not have traction but the other wheel does have traction. It also provides a straight in line steering aid when opening up the field and to control implement overlap.

TO ENGAGE THE DIFFERENTIAL LOCK:

Depress and hold the differential lock pedal down.

IMPORTANT: Do not engage the differential lock while one rear wheel is rotating and the other rear wheel is stopped. Always stop the wheel that is rotating and then engage the differential lock.

IMPORTANT: When you engage or disengage the differential lock, the front wheels must be in the straight forward position. Before turning the tractor, disengage the differential lock.

TO DISENGAGE THE DIFFERENTIAL LOCK:

The differential lock will disengage when the differential lock pedal is released. If the differential lock does not disengage easily, push down on either brake pedal instantaneously.



Do not drive on roads, or at high speed anywhere, with the differential lock engaged. Difficult steering will occur, and can result in an accident. In field operation, use the differential lock for traction improvement, but release for turning at row ends.

POWER TAKEOFF (REAR PTO) : Gear Drive



WARNING: PTO driven machinery can cause serious injury or death, usually due to wrapped clothing. When required by the job to be in the drive shaft area, stay clear of rotating parts. Before working on the drive shaft, or servicing or clearing the driven machine, where applicable on this tractor, put the PTO clutch lever in the DISENGAGE position, the PTO lever in the NEUTRAL or OFF, and STOP the engine.

Rear PTO

The rear PTO is a 540 RPM with a 34.9 mm (1 3/8 inch) diameter 6 spline output shaft.

ENGAGE THE REAR PTO AS FOLLOWS:

1. Confirming disengage the clutch, pushing the PTO switch.
2. Move the PTO control lever to the ON position.
3. Turn right PTO switch to engage the PTO clutch. (turning the PTO shaft)

DISENGAGE THE REAR PTO AS FOLLOWS:

1. Push the PTO switch to disengage the PTO clutch. (stop the turning of PTO shaft)
2. Move the PTO control lever to the OFF (Engine Start) position.

NOTE: Keep the PTO control lever in the OFF (Engine Start) position when starting the engine and when the PTO is not being used.

The following table shows the required speed to get the required Rear PTO output shaft speed.

Push the PTO switch in the emergency. The rotation of PTO stops.

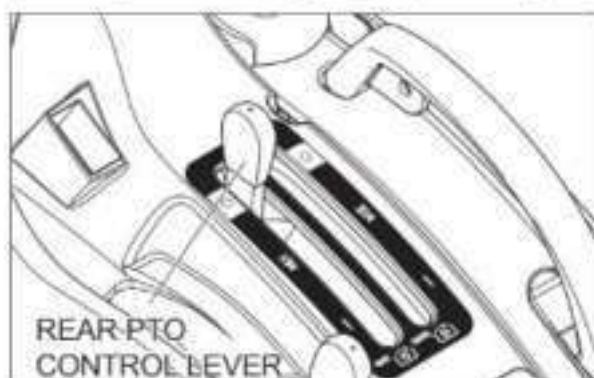
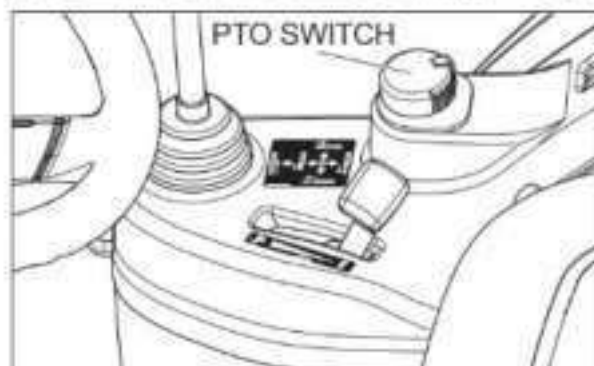

PTO Output Shaft Speed	Required Engine Speed
540 RPM	2376 RPM

POWER TAKEOFF (REAR PTO) : Hydrostatic Drive



PTO driven machinery can cause serious injury or death, usually due to wrapped clothing. When required by the job to be in the drive shaft area, stay clear of rotating parts. Before working on the drive shaft, or servicing or clearing the driven machine, where applicable on this tractor, put the PTO clutch lever in the DISENGAGE position, the PTO lever in the NEUTRAL or OFF, and STOP the engine.

Rear PTO

The rear PTO is a 540 RPM with a 34.9 mm (1 3/8 inch) diameter 6 spline output shaft.

ENGAGE THE REAR PTO AS FOLLOWS:

1. Push the clutch pedal fully.
2. Move the PTO control lever to the ON position.
3. Release the clutch pedal slowly.

DISENGAGE THE REAR PTO AS FOLLOWS:

1. Push the clutch pedal fully.
2. Move the PTO control lever to the OFF (Engine Start) position.
3. Release the clutch pedal slowly.

NOTE: Keep the PTO control lever in the OFF (Engine Start) position when starting the engine and when the PTO is not being used.

The following table shows the required speed to get the required Rear PTO output shaft speed.

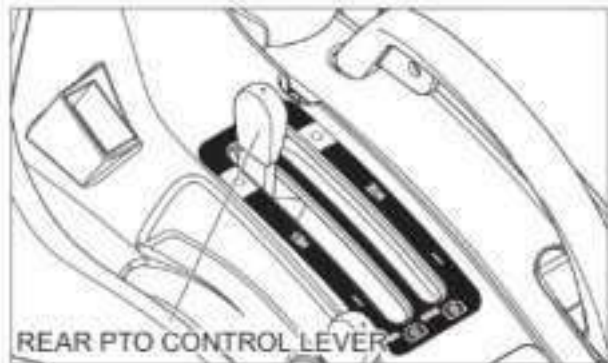
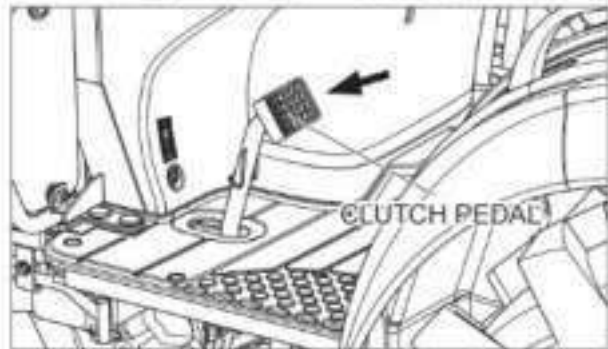

PTO Output Shaft Speed	Required Engine Speed
540 RPM	2376 RPM

LOADER VALVE JOYSTICK OPERATION

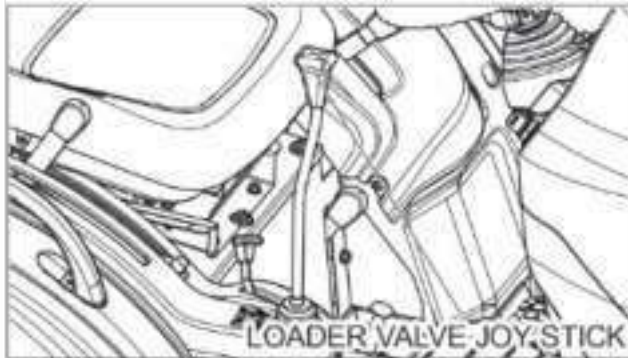

Joystick is utilized to control cylinder connected to port of loader valve and it will function as described.

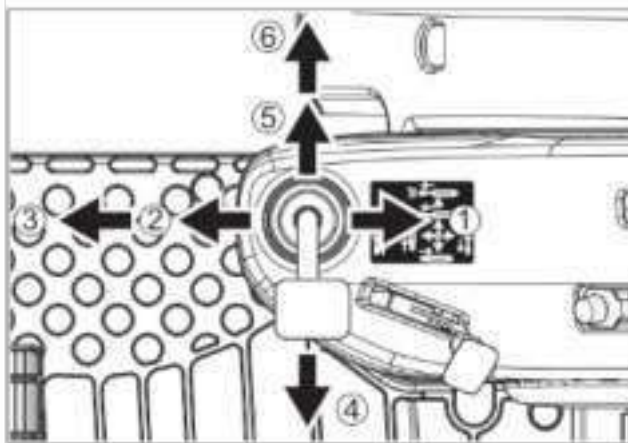

JOYSTICK POSITION

- ①. Push the handle full forward to activate float position.
- ②. Push the handle forward to shorten lift cylinder connect rod end of lift cylinder to port A2.
- ③. Push the handle rearward to lengthen lift cylinder connect base end of lift cylinder to port B2.
- ④. Pull the handle inward to shorten tilt cylinder connect rod end of tilt cylinder to port B1.
- ⑤. Push the handle outward to lengthen tilt cylinder connect base end of tilt cylinder to port A1.
- ⑥. Push the handle further outward to activate regen position which will dump attachment at a faster rate.

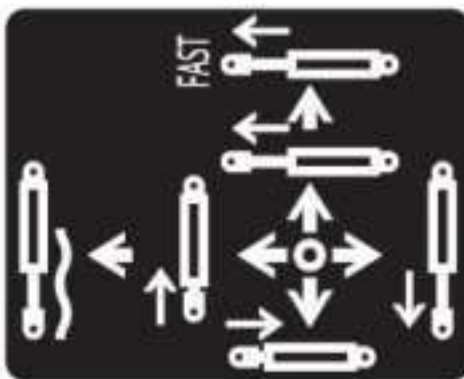

NEUTRAL POSITION

The loader valve has a "neutral position" which prevents movement of loader or other applications. When the joystick is manually released from the work position, the valve spool will return to the neutral position.

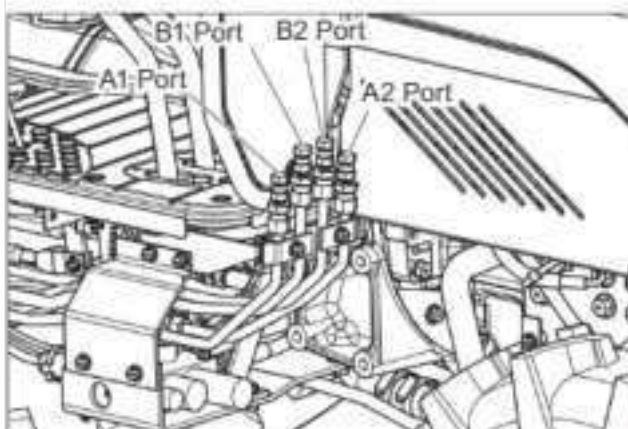

FLOAT POSITION

The loader valve has a "float position". To activate float position, push the joystick all the way forward into detent. The valve will stay in float position until the operator manually pulls joystick out of detent position to deactivate float.

IMPORTANT : Never use joystick as a handle when getting on or off of tractor. Failure to follow these instructions will cause joystick damage not covered under warranty.

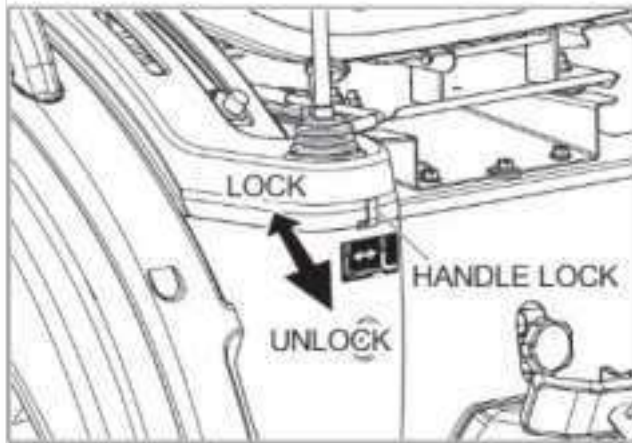
**HANDLE LOCK AND UNLOCK POSITION**

Loader valve is equipped with a valve handle lock. This handle lock allows the operator to lock the loader valve joystick in the neutral position. It should always be used when the tractor is not in use and when traveling a long distance with an empty loader attachment.



1. To lock the joystick, push the lock lever forward to locked position.
2. To unlock the joystick, pull the lock lever rearward to unlock position.

POWER TAKEOFF GUARDS

All tractors have a safety guard for the Rear PTO shaft and safety cover for the Mid PTO shaft.

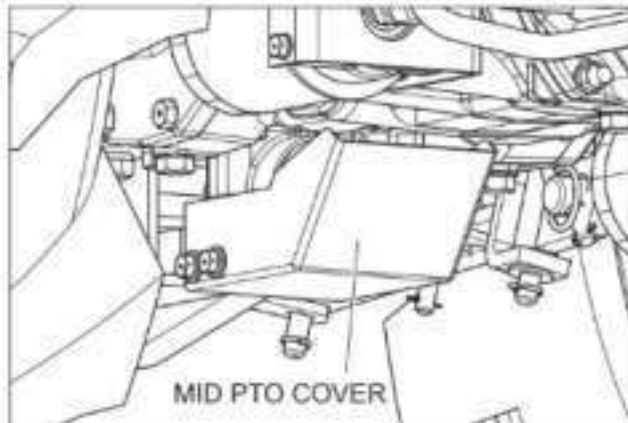
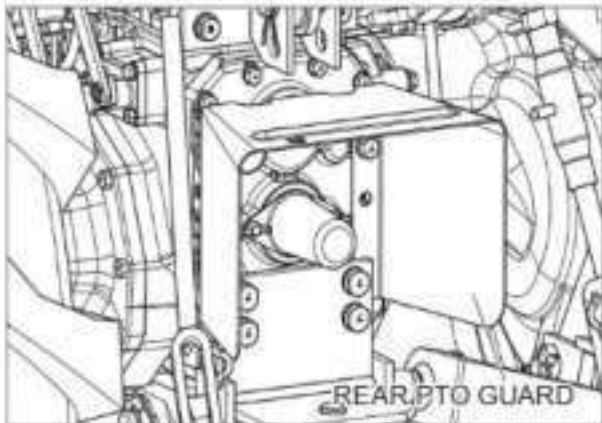

Whenever a PTO driven machine is in operation, the PTO guard must be in place for most operations to prevent injury to the operator or bystanders. Where attachments, such as pumps, are installed on the PTO shaft (especially if the tractor PTO guard is moved upward or removed) extended shielding equivalent to the PTO guard must be installed with the attachment. Install the PTO guard to its original position immediately when the attachment is removed.

STATIONARY REAR PTO WORK

According to the following instructions, use the Rear PTO for chipper, pump, or other stationary implements.

In this way, only the Rear PTO can be used.

1. Set the blocks at the tires.
2. Sit on the operator's seat.
3. Apply the parking brake.
4. Make sure the all operating control levers are in "N" or "OFF".
5. Depress the clutch pedal and start the engine.
6. Shift the Rear PTO control lever to "ON".
7. Adjust the proper engine speed for the Rear PTO work.
8. Leave the operator's seat.

NOTE: If you leave (stand up from) the seat when the Mid PTO is engaged, safety system will automatically shut down the engine.



If you leave the tractor with engine automatically shutting down, the battery is running down and possibly dead.

To prevent it turn key switch to OFF position in case engine automatically shutting down.

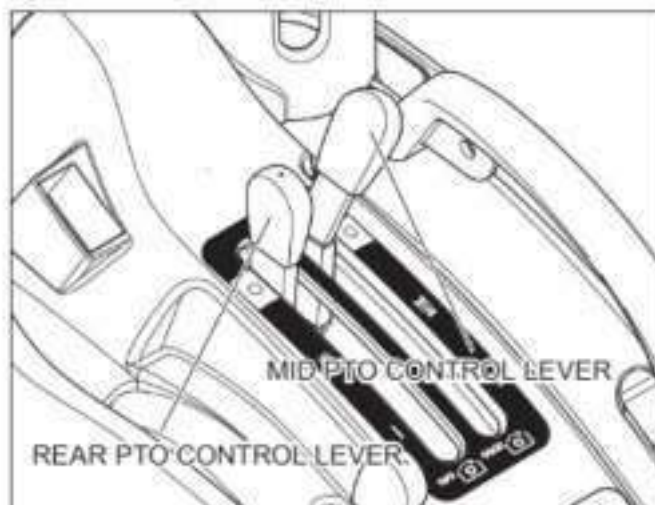

PTO OPERATING SAFETY

For the safe operation of the PTO, follow these safe operating procedures.

Three Point Hitch Connecting Implements

1. Connect the implement to the hitch.
See **THREE POINT HITCH SYSTEM** in this manual.
2. Connect the implement driveline to the tractor.
3. Check the driveline for correct length and for free telescopic movement by lifting and lowering hitch system. The correct length is important to prevent the driveline from hitting bottom or from separating in any tractor implement operating position.

Drawbar Connecting Implements

1. Connect the implement hitch to the drawer with a hardened steel pin. Make sure the pin is securely held in place with a cotter pin or lock pin and does not make contact with the implement driveline.
2. Connect the implement hitch to the tractor drawbar before connecting the implement driveline to the PTO
3. Connect the implement driveline to the tractor. Check the driveline for correct length and for free telescopic movement. The correct length is important to prevent the driveline from hitting bottom or from separating in any tractor or implement operating position.



PTO driven machinery can cause serious injury. Before working on or near the PTO shaft, or servicing or clearing the driven machine, put the PTO lever in the **DISENGAGE** position and **STOP** the engine.



When doing stationary PTO work and dismounting from the tractor with the PTO running, keep clear of all moving parts as they are a potential safety hazard.

IMPORTANT: Follow the implement manufacturers recommendations in adjusting and aligning the implement and implement driveline with the tractor.

DRAWBAR

Your tractor is equipped with a drawbar. Use the drawbar for connecting all pull-behind implements.

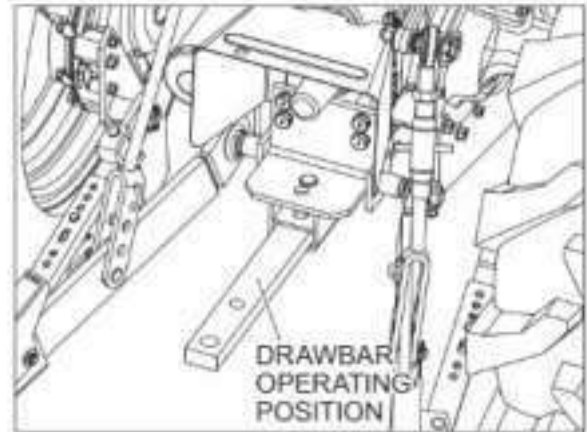
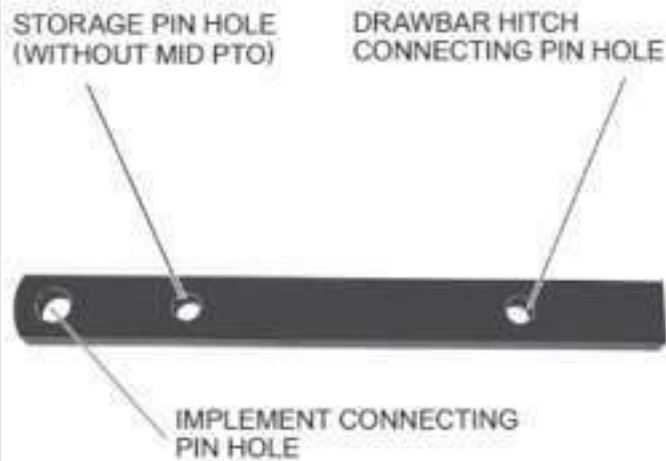

The drawbar must be in the storage position when using the three-point hitch.

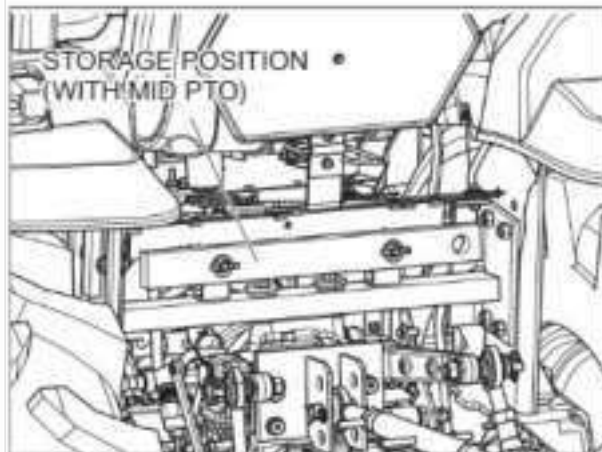

WITH MID PTO

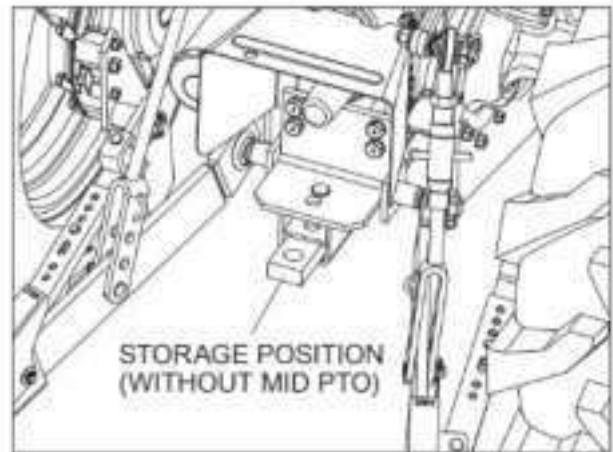

WITHOUT MID PTO



Try to balance the load primarily on the implement wheels – as in loading a trailer or spreader. Avoid overloading the drawbar. Add front end weights for improved stability. Engage the clutch smoothly, avoid jerking and use the brakes cautiously to avoid jackknifing.



Rear upset can result if pulling from wrong location on tractor. Hitch only to the draw bar. Use 3 point hitch only with the implements designed for its use – not as a draw bar.

WARNING LAMPS



The lamp switch has three positions. Turn the switch clockwise to illuminate the headlamp and rear red lamp.

Push the hazard switch down to operate the amber warning lamps.

When the turn signal switch is moved turns the right hand to make a right turn, the RH warning lamp will illuminate ON and OFF and the LH lamp will illuminate continuously.

When the turn signal switch is moved turns the left hand to make a left turn, the LH warning lamp will illuminate ON and OFF and the RH lamp will illuminate continuously.

When the turn signal switch is returned to the center position, both warning lamps will illuminate ON and OFF.

IMPORTANT: When towing an implement or wagon by the tractor, the complete rear area warning system (amber warning lamps, rear red lamp and SMV emblem) must be easily seen by any vehicle operator coming near the tractor.

CONNECTING IMPLEMENT TO DRAWBAR

The correct connection of the implement to the drawbar will prevent stress on both the tractor and the implement.

To assure proper tractor operation and optimum implement performance, the implement must be connected to the drawbar correctly.

1. Connect pull-behind implements to the drawbar only.
2. Use a hardened steel hitch pin to connect the implement to the drawbar. Make sure the pin is held securely in place with a lock pin.
3. When working with the drawbar, raise the lower links as high as possible to prevent interference between the lower links and the implement.
4. The drawbar provides the standard hitch distance from the end of the PTO shaft to the centerline of the rear hole in the drawbar. This is necessary for safe PTO operation of trailing type equipment.

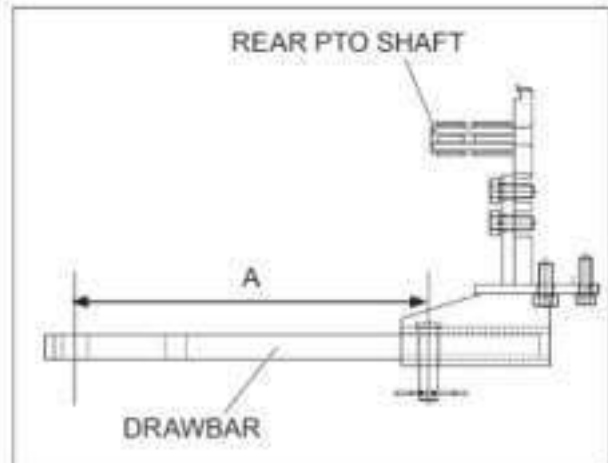
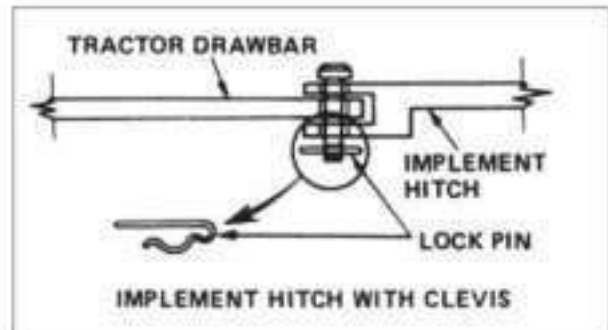

PTO RPM	PTO SHAFT DIAMETER	DIMENSION A
540	1.375 In (34.9 mm)	14 In (358 mm)

IMPORTANT: The maximum fixed drawbar vertical load is 440 kg(970 lbs)

FIELD OPERATION

SAFETY CHAIN

When towing equipment on a highway, use a safety chain as an auxiliary connection between the tractor and the towed equipment. The safety chain must have a rating greater than the gross load of the towed equipment. Connect the chain to the tractor drawbar support and the towed equipment as shown in the illustration. Check the adjustment of the safety chain by turning the tractor completely to the right and left. Adjust the chain as necessary.

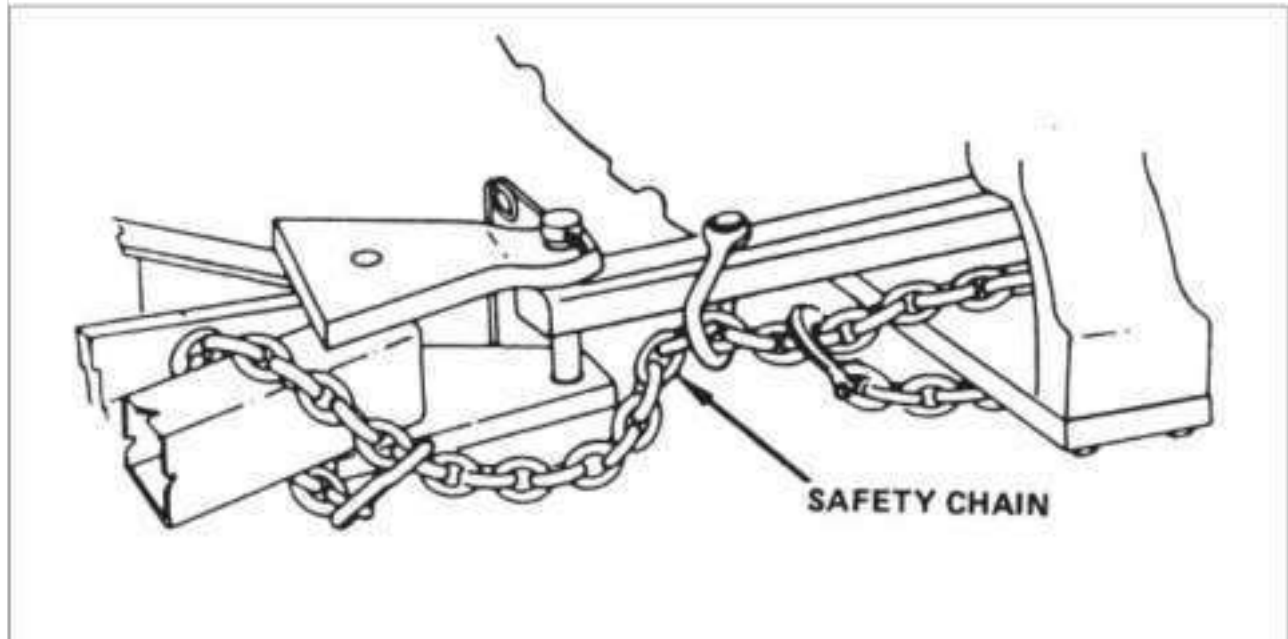

THREE POINT HITCH SYSTEM

The three point hitch system gives position control of implements.

This tractor is equipped with a category I hitch.

The three-point hitch dimensions are shown in the following table.

Implement identification Dimensions	Cat I Implement
A - Gap in top of implement mast	44.5 mm (1-3/4 inch)
B - Diameter of holes in top of Implement mast	19.1 mm (3/4 inch)
C - Diameter of hitch pins	22.2 mm (7/8 inch)
D - Lower Hitch Pin Inner Shoulder Spread	682.6 mm (26-7/8 inch)

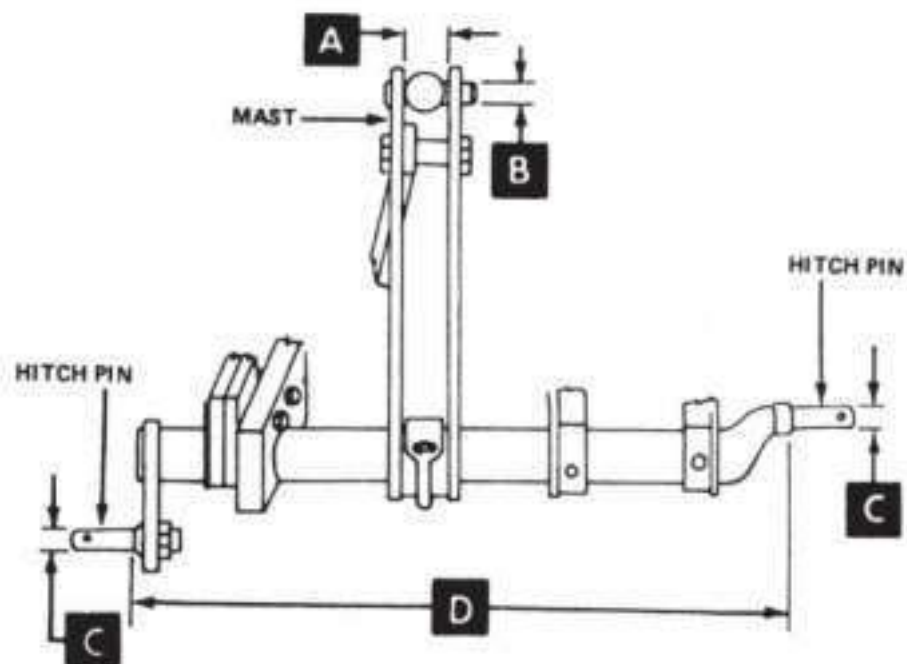

HITCH SYSTEM ADJUSTMENTS

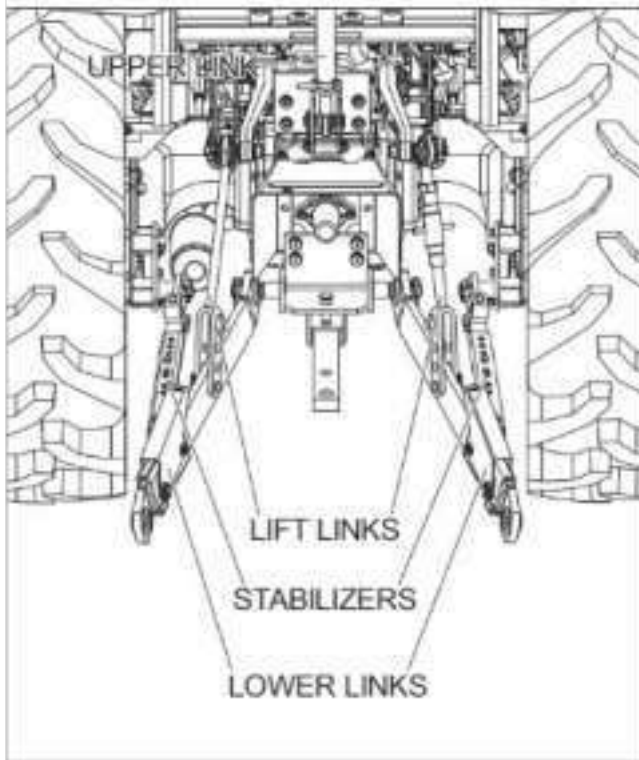

The upper and lower links must be adjusted correctly so the implement can work at the needed depth and the links are free to move up and down with the shape of the ground.

Lift Links

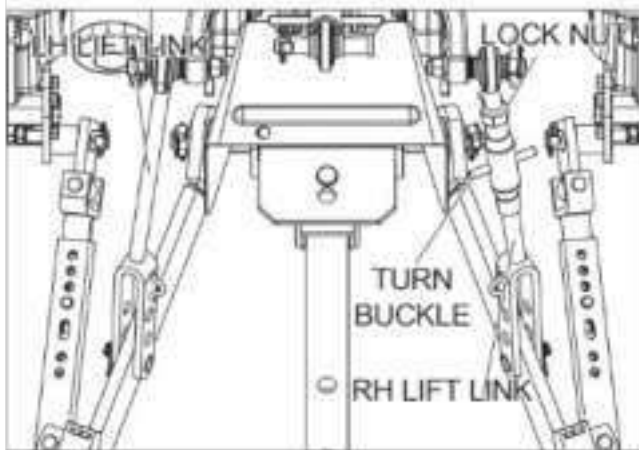

1. Connect the lift links to the lift arm of the tractor and to the lower links. Make sure the lift links are installed on the proper side as shown.
2. The RH side lift link is adjustable by the turnbuckle to obtain the desired position of the hitch point.
Turn the turnbuckle clockwise to shorten the link or counterclockwise to lengthen the link.

IMPORTANT: After the lift link is adjusted, make sure the locknut is tightened against the turnbuckle.

Upper Link

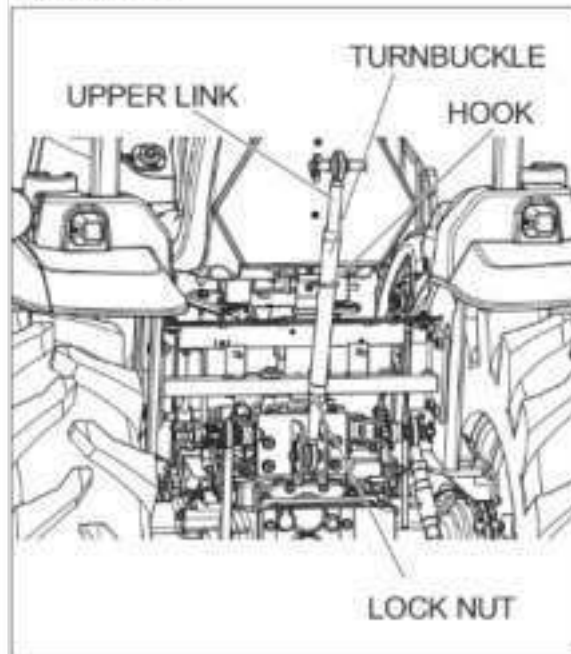

The length A of the upper link can be adjusted from 470 to 750 mm (18.5 to 29.5 inches).

Turn the turnbuckle clockwise to shorten the link or counterclockwise to lengthen the link.

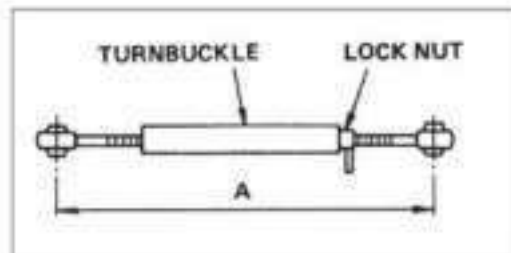

IMPORTANT: After the upper link is correctly adjusted, make sure the lock nut is tightened against the turnbuckle.

Stabilizer

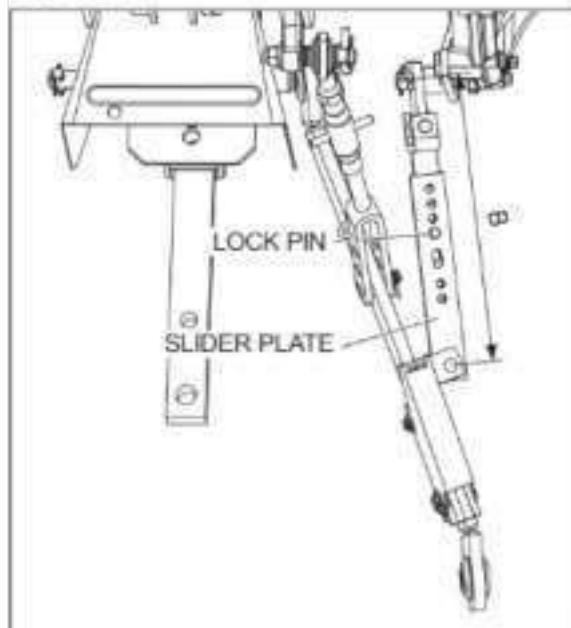

When side movement of the hitch is undesirable or hazardous, the lateral swing is adjusted by select hole on the stabilizer.

Slide REAR STABILIZER and adjust hole REAR and FRONT STABILIZER set clevis pin the hole.

IMPORTANT: After making final adjustments carefully raise the implement to make sure that there is proper clearance between the implement and tractor components.

NOTE: Insert pin to hole in clevis pin surely.

IMPORTANT: When the implement is not installing, adjusting to becoming dimension B=325mm(12.8inch) or more length of the stabilizer.

Even if lower links shakes, it checks that it is not in contact with a tire.

stabilizer may be changed or damaged if tire contacts lower links.

IMPORTANT: Adjust hole to reduce the load, if the pressed STABILIZER is applied the load when the implement sways left and right.

HITCH OPERATION

Connecting Implement to Hitch

To connect an implement to the hitch, use the following procedure:

NOTE: Be sure the tractor and implement are on level ground.

1. Put the drawbar in the storage position.
2. Slowly move the tractor backwards to the implement.
3. When the hitch points on the tractor and implement are in the correct position, stop the tractor.
4. Apply the park brake and stop the engine.
5. Press the bracket (A) in lower link and pull link (B) to extend as needed.

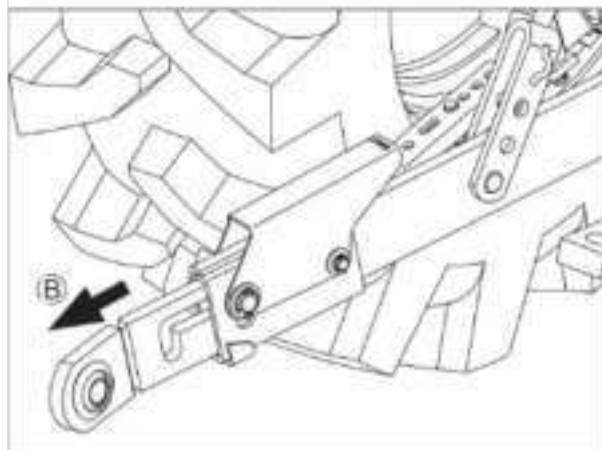
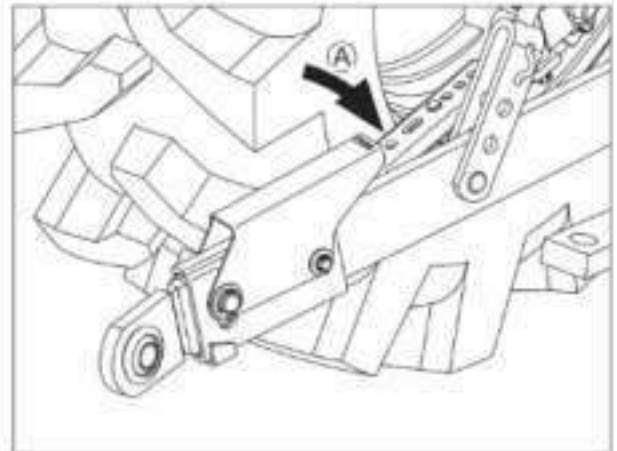
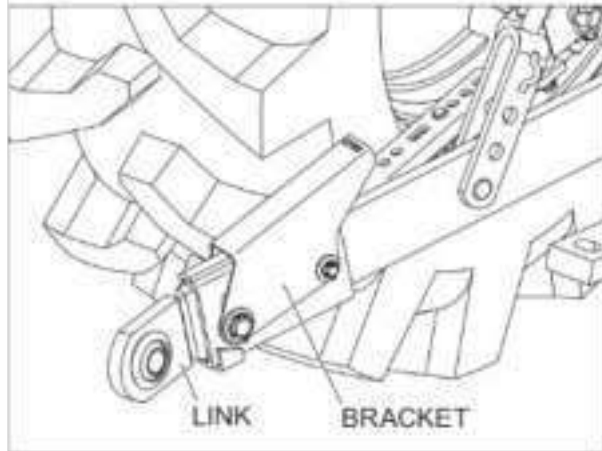

6. Connect lower links to the implement. Sit on operator's seat and start engine.
7. Back tractor until each lock lever snaps and secures each lower link into the lock position.
8. Connect the implement to the Upper Link.
9. Adjust the Upper and Lower Links as necessary. See Hitch System Adjustments in this manual.

Disconnecting Implement from Hitch

To disconnect an implement from the hitch, use the following procedure:

NOTE: Be sure the tractor and implement are on level ground.

1. Stop the tractor completely and apply the park brake.
2. Disengage the PTO, lower the implement to the ground.
3. Gear Drive: Place the gear shift and range shift levers in Neutral.
Hydrostatic Drive: Release the speed lock lever, and place the range shift lever in Neutral.
4. Stop the engine and remove the key from the key switch before leaving the tractor.
5. Disconnect the implement from the hitch.

NOTE: Be sure the tractor and implement are stable and free from any tendency to roll over.

Hitch Control Lever

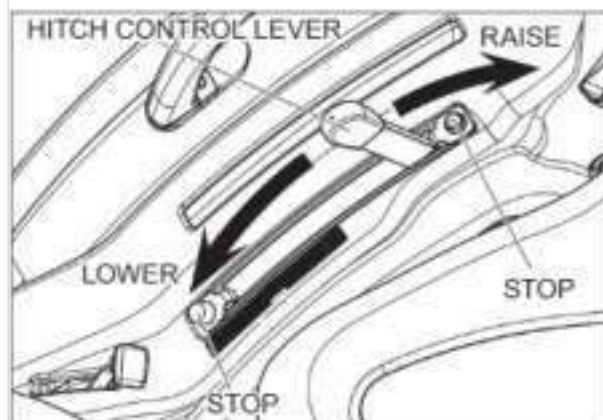

The hitch control lever is used to raise or lower the implement mounted to the three point hitch. To raise the hitch, move the lever to the rear. To lower the hitch, move the lever forward.

Adjustable stops are provided for use whenever it is desirable to return the hitch control lever to the same operating position.

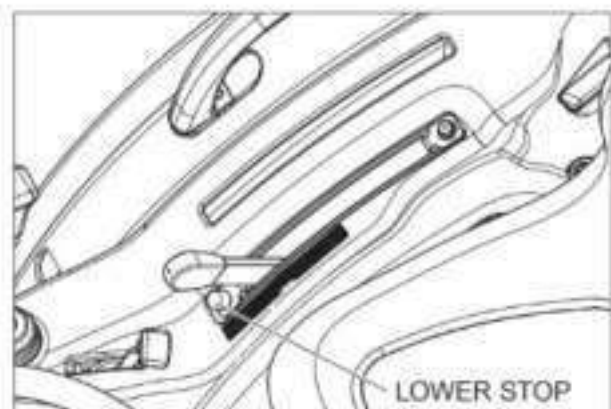
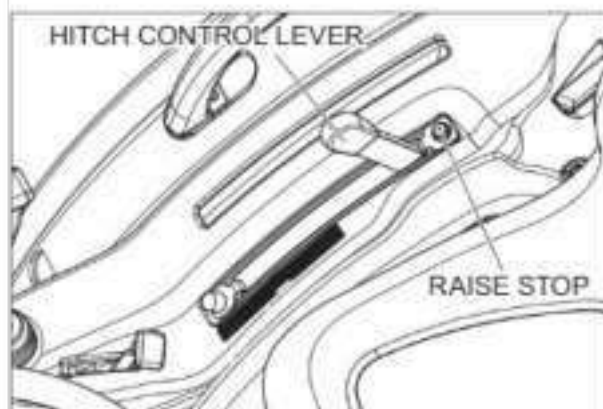

IMPORTANT: The position of the raise stop should not be set so rearward that a insufficient free play of the lift arms is available at the highest position when hitch control lever is moved until the lever is reached to the raise stop.

FIELD OPERATION

Hitch Lowering Speed Adjustment

To adjust the hitch lowering speed, use the following procedure:

1. Move the hitch control lever forward to lower the implements.
2. Turn the hydraulic flow control knob to adjust the lowering speed. Turn the knob counter clockwise to increase the lowering speed. Turn the knob clockwise to decrease the speed or lock the hitch.
3. After adjusting the speed, raise the hitch and then lower it to check the speed.

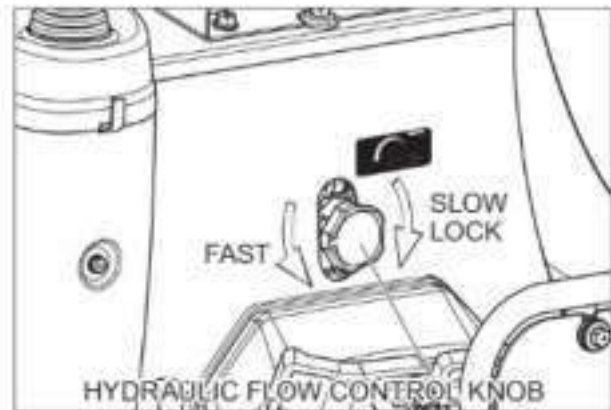

NOTE: When transporting the tractor on the road with the implement mounted on the three point hitch, always set hydraulic flow control knob to the LOCK position.

IMPORTANT: Never park a tractor with an implement in the raised position. Moving the hitch control lever forward will lower the implement even though the engine is not running. If it is necessary to service the implement in the raised position, use jack stands to safely block the implement in place. Put the hydraulic flow control knob in the LOCK position.



Lower or block elevated implements and other attachments before servicing or when leaving the equipment.

HYDRAULIC BLOCK

A hydraulic block is located on the right side of the tractor. This block can provide an external hydraulic circuit for loader use or other applications. See your dealer.

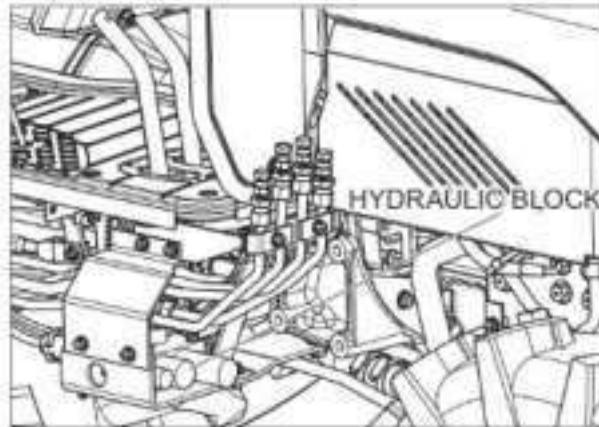

IMPORTANT: Never park a tractor with an implement in the raised position. Moving the hitch control lever forward will lower the implement even though the engine is not running. If it is necessary to service the implement in the raised position, use jack stands to safely block the implement in place. Put the hydraulic flow control knob in the LOCK position.

FIELD OPERATION

Adding Fluid after Connecting Cylinders and Hoses

Operate the engine at a moderate idle speed. Set the stroke stop at the yoke end of the cylinder rod to provide maximum stroke. Then operate the cylinder in both directions about five times at least by moving the control lever up and down.

This will fill the cylinder and hoses with fluid and remove the air from the system. Fill the cylinder completely, stop the engine and check the fluid level with the transmission dipstick.

Add sufficient, clean specified fluid to bring the oil up to the proper level.

See TRANSMISSION AND HYDRAULIC LUBRICATION in this manual.

NOTE: If any of the hydraulic units are removed and replaced for any reason, check the oil level and add the specified fluid to the transmission to bring the oil up to the proper level.



When remote cylinders are connected to the hydraulic system, cycle the control lever about five times to remove air from the cylinder and hoses. With air in the system, raised equipment can drop accidentally and cause personal injury or machine damage.



Hydraulic oil or diesel fuel leaking under pressure can penetrate the skin and cause infection or other injury.

To Prevent Personal Injury:

Relieve all pressure, before disconnecting fluid lines.

Before applying pressure, make sure all connections are tight and components are in good condition.

Never use your hand to check for suspected leaks under pressure.

Use a piece of cardboard or wood for this purpose.

If injured by leaking fluid, see your doctor immediately.



The implement should be lowered to the ground before uncoupling of the remote hydraulic hoses.



Lower or block elevated implements and other attachments before servicing or when leaving the equipment.

TIRE AND RIM EQUIPMENT

Tire Inflation Specifications

For normal tractor operation use the inflation pressure shown in the tire and wheel chart. The inflation pressure are based on cold inflation pressure recommendations by Tire and Rim Association Inc.

For maximum tractor performance, always adjust the tire pressure within the minimum/maximum range to conform with the actual load on the tires. Under normal conditions, use the minimum pressure rating for general drawbar work. Use the higher pressure rating, up to the maximum, for heavy three point hitch mounted equipment, or heavy front and mounted equipment.

Example A shows the cross section of a tire inflated for maximum load but with a minimum load on the tire. The tire tread is not making full contact with the ground which will give poor performance.

Example B shows the cross section of a tire with inflated pressure correctly adjusted to the load on the tire. The tire tread is making full contact with the ground which will give maximum performance.

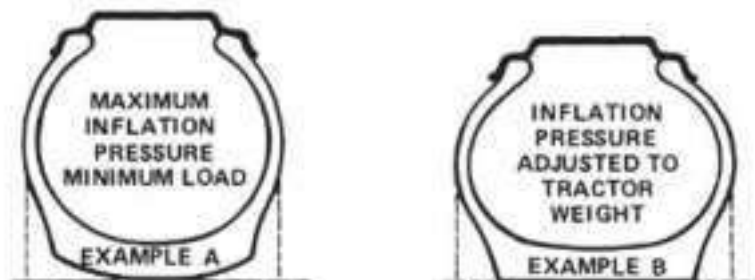

Tire pressure can also be adjusted as required to satisfy the following requirements.

- A. Severe Service. Tire pressure can be increased 28 kPa (4 psi) more than the maximum pressure shown in the chart for tires used in severe service. Severe service includes the furrow tire in regular plowing operations, the downhill tire in plowing and in other hillside operations.
- B. Tires With Liquid Ballast. Inflate the tires 14 kPa (2 psi) more than the recommended pressure. This will compensate for aeration that occurs when the tires are in motion.

IMPORTANT: During transportation on a railroad car or trailer, the tractor tires are often inflated to higher than normal operating pressures. Before using your tractor, check the air pressure in the tires to make sure that the air pressure does not exceed the maximum pressures shown in the tire and wheel equipment chart.

TIRES/WHEELS/SPACING/BALLAST



A tire can explode during inflation and cause serious injury or death. Never increase air pressure beyond 35 psi to seat the bead on the rim. Replace a tire if it has a defect. Replace a wheel rim which has cracks, wear or severe rust. Make sure that all the air is removed from a tire before removing the tire from the rim. Never use force on an inflated or partially inflated tire. Make sure the tire is correctly seated before inflating.

Tire Load Capacity

The maximum load capacity, shown in the tire pressure and load capacity chart, is of the wheel with the tire inflated to the maximum pressure. Do not exceed the maximum load capacity of the tire.

TYPE	POSITION	TIRE SIZE	TIRE RATING	MAX LOAD CAPACITY AT MAX INFLATION PRESSURE	INFLATION PRESSURE
INDUSTRIAL TIRES	FRONT	28X8.50-15	6PR	1960 lbs	45 psi
	REAR	43X16.00-20	4PR	3080 lbs	20 psi

Check Air Pressure

Tire Pressure Check Interval ... Every 50 hours of operation or weekly.

Check the condition of the tires and rims for wear or damage. Keep the tires inflated to the recommended pressures. See Tire and Wheel Specifications in this manual for recommended inflation pressures for each tire size.

For tires equipped with liquid ballast, check the air pressure as follows:

1. Use an air-water gauge. The valve must be at the bottom of the tire to get an accurate reading.
2. Use a standard air gauge as follows:
 - A. The valve must be at the top of the tire.
 - B. Measure the rim diameter.
 - C. Add 3.5 kPa (1/2 psi) for each 305 mm (12 inches) of rim diameter to the standard gauge reading.

Tire Inflation Procedure



A tire can explode during inflation and cause serious injury or death. Never increase air pressure beyond 35 psi to seat the bead on rim. Replace a tire if it has a defect. Replace a wheel rim which has cracks, wear or severe rust. Make sure that all the air is removed from a tire before removing the tire from the rim. Never use force on an inflated or partially inflated tire. Make sure the tire is correctly seated before inflating.

DO NOT inflate a tire that has had a complete loss of air. If the tire has lost all air pressure, have a qualified tire mechanic service the tire.

To add air to a partly inflated tire, use the following procedure:

1. Use an air hose with a remote shutoff valve and a self – locking air chuck.
2. Stand behind the tread of the tire and make sure all persons are away from the side of the tire before you start to add air.
3. Inflate the tire to the recommended air pressure. DO NOT inflate the tire more than the recommended pressure.

NOTE: Tires can be inflated 28 kPa (4 psi) over maximum recommended in chart when tractor is used for heavy draft operation and ground compaction is not a problem.

FRONT AND REAR WHEEL ADJUSTMENT



The front wheels are tightened with six bolts for MFD to the axle hubs.
The rear wheels are tightened with six bolts to the rear axle hubs.

Torques for wheel bolts as follows:

BOLTS POSITIONS	TORQUE
Front wheel disc to axle hub bolts	118 to 132 N·m(87 to 98 Lbf·ft)
Rear wheel disc to axle hub bolts	118 to 132 N·m(87 to 98 Lbf·ft)

IMPORTANT: Check the wheel bolts and nuts after the first 10 hours of operation and again after every 100 hours of operation. Also do this procedure any time the wheel or rim is removed.

NOTE:

1. The front wheel of tires must always be assembled with the valve side out.
2. When putting the wheels on the axle, make sure that the tires rotate in the correct direction.
See Tire Installation in this manual.

TIRE SIZE COMBINATIONS-MFD

Your MFD Tractor must use front and rear tire combinations that are correctly matched. The use of recommended tire combinations will give maximum tractor performance, extended tire and reduced wear on drive train components.

IMPORTANT: The tire size combinations shown below are specified to provide matched ground speeds of the front and rear tires. Mixing worn and new tires or tires of different diameters or loaded radii can give incorrect ground speed match. When replacing tires, consult your Dealer.

TYPE	POSITION	TIRE SIZE	TIRE RATING
INDUSTRIAL TIRES	FRONT	28X8.50-15	6PR
	REAR	43X16.00-20	4PR

TRACTOR BALLAST

Ballast for your tractor includes front-end weights, rear wheel weights and liquid ballast in the rear tires. Front-end weights improve the steering characteristic when heavy hitch loads cause a movement of tractor weight from the front to the rear wheels. Rear wheel weights and adding liquid to the rear tires increase traction by putting weight on the driving wheels.

IMPORTANT: The Maximum operating weight of tractor should not exceed the following values. The operating weight of tractor includes the weight of tractor, ballast weight and implement.

Front Axle	1500kg (3307lbs)
Rear Axle	1500kg (3307lbs)
Total	2535kg (5589lbs)

CRITICAL NOTE: Mahindra 1538L loader is the only approved loader for use on the 1640 tractors see 1538L loader operator manual for loader/tractor specifications.

Front End Weights

Front-end weights can be mounted on the front-end bracket of the tractor with locking bolts and nuts. The weights, locking bolts and nuts are available from your Dealer. A maximum of three weights at 22 kg (49 lbs) each can be installed, depending on implement application and soil conditions.

Use front-end weights as needed to provide effective steering control and front end stability and to achieve maximum operating efficiency and tractor field performance.

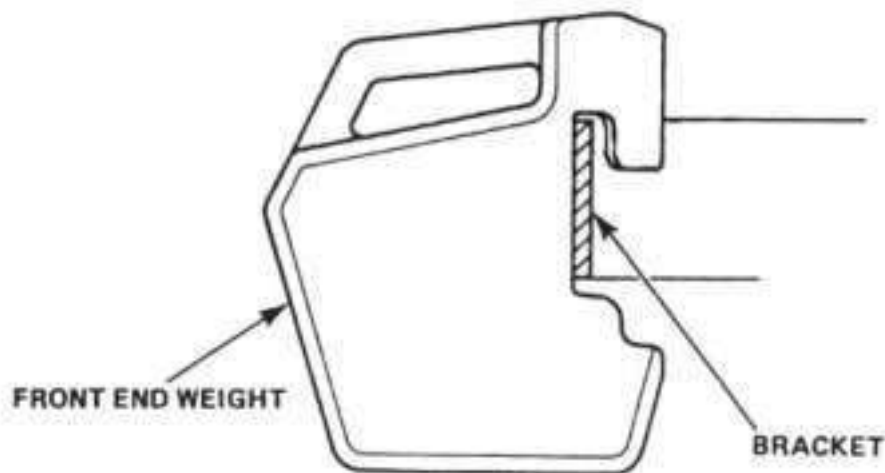

NOTE: When you have too much ballast installed on the tractor, you will see the clear shape of the tire tread in the ground which is an indication of no slippage. With too little ballast, the tire tread marks will not show because of the tire slippage.

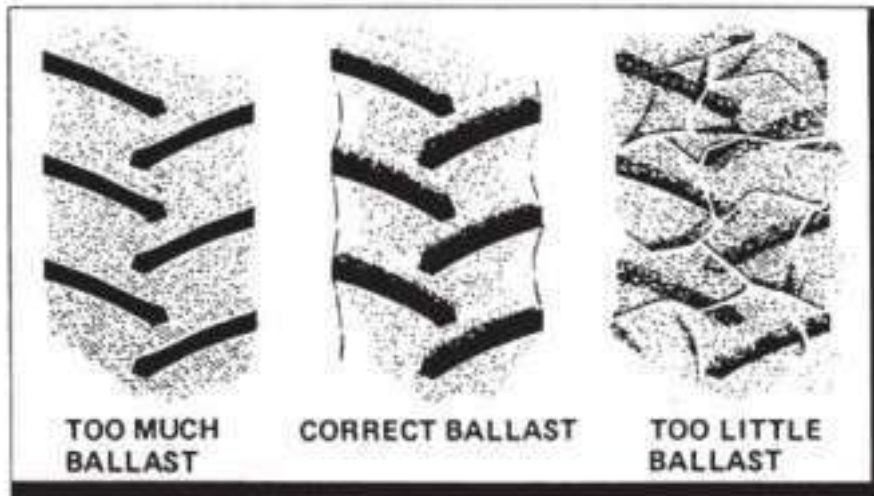

HOOD

To do maintenance work on the engine lubrication system, cooling system, fuel system and air induction system, you must lift the tractor hood and remove the side cover.

STEP1

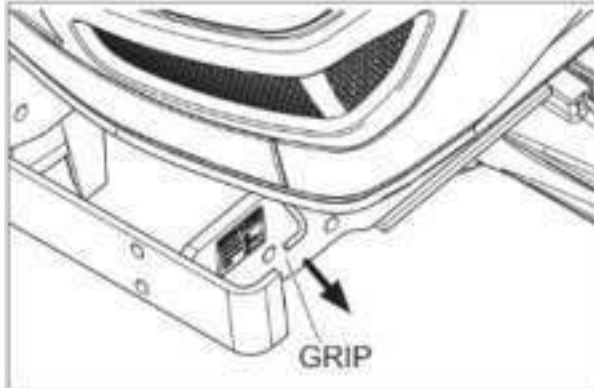

Pull the Grip to release the lock.

STEP2

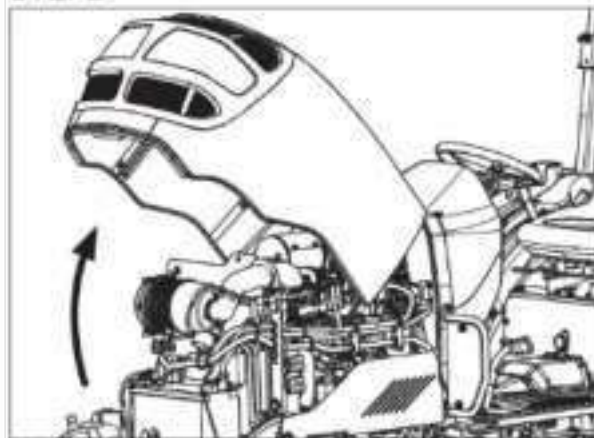

Push the front of the hood upward as shown.

STEP3

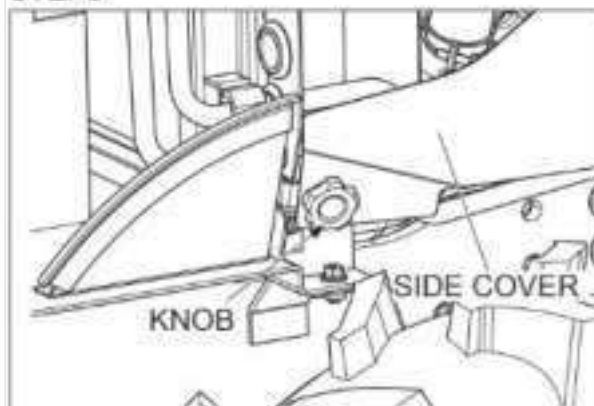

Remove the knob bolt. (The following procedures are the same for both sides.)

STEP4

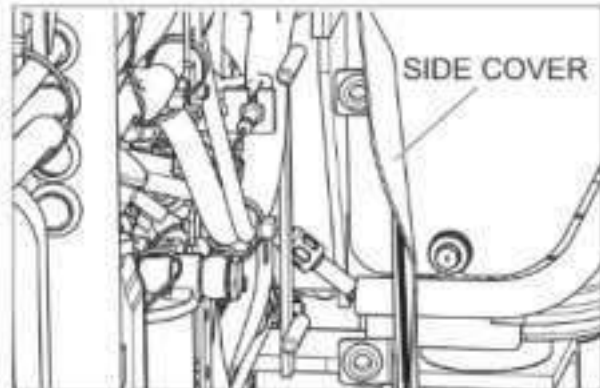

Slide the side cover as pulling it forward, and remove the side cover.

Lubrication Table

Application	Kind of Oil	API Classification	Ambient temperature	Grade (SAE No.)		Description	Recommendation Oil Brand				
				Single	Multi						
Engine	Engine Oil	CJ-4	-25° C (-14° F)	5W	5W-20	Use high Grade Diesel Oil	(For 15W 40 oil) Mahindra SAE 15W-40 Deccal engine oil Citgo-Citgard 600 15W 40 Chevron-Dele 400LE Mobil-Devias Elite Shell-Rotella T3 Texaco-Ultra Premium TDS EC SAE 15W40 ESSO - XDS Extra CJ4				
			-20-0° C (-4-32° F)	10W	10W-30 15W-40			Engine Oil			
			-10-10° C (14-50° F)	20W		Use high Grade Diesel Oil					
			0-20° C (32-68° F)	20							
			10-30° C (50-86° F)	30							
			30° C (86° F)	40	20W-40						
			Transmission oil front diff. oil	Hydraulic Transmission Fluid		Hydraulic Transmission Fluid					Mahindra Universal Tractor Hydraulic Fluid Citgo-Transgard Tractor Hydraulic Fluids Exxon-Torque Fluid 58 Chevron-Chevron 1000 THF Mobil-Mobil Fluid 424 Shell-Dorex TD Texaco-THD oil Special
			Grease Nipple	Grease							Use good grade grease designed for pin and bushings on agricultural equipment. Lithium or aluminum complex type grease with high viscosity base oil, talc and molybdenum disulfide are suitable. Grease approved for the NLGI certification mark GC-LB are recommended.

SERVICE HOUR INTERVAL

Service your tractor at the intervals and locations given on the Lubrication and Service Chart. When you service your tractor, use only high quality lubricants.

Engine Hour meter

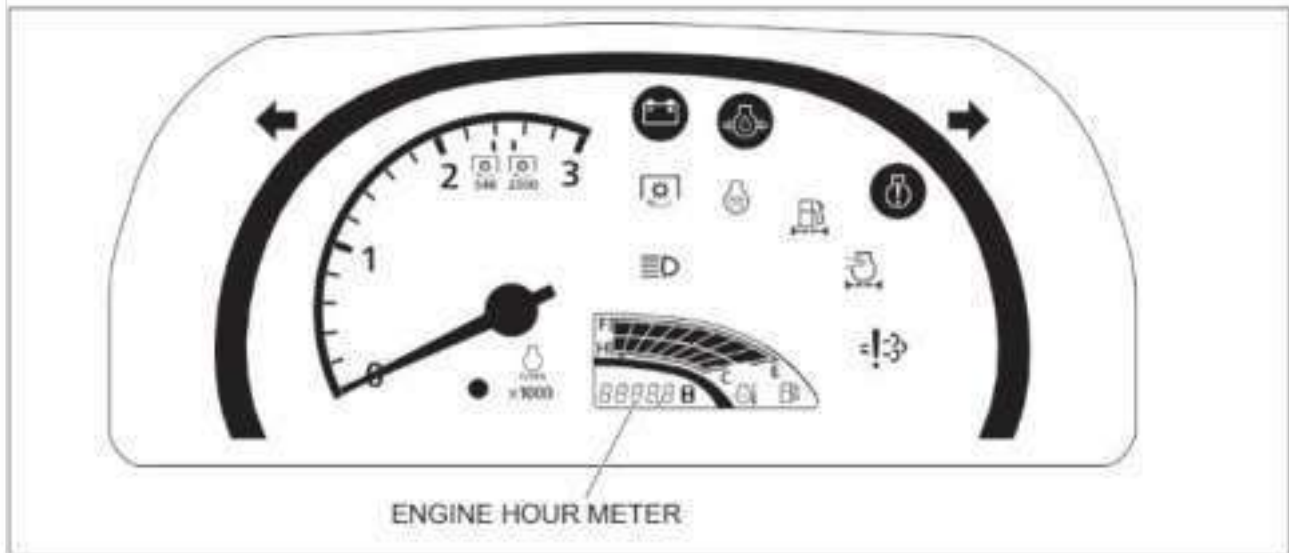

The engine hour meter shows the total amount of actual engine operated hours of the tractor. The first number to the right side displays added one by one every six minutes. The remaining numbers are displays added one by one every one hour. Use the hour meter along with the Lubrication Chart to service your tractor at the correct time periods.

Service After First 50 Hours

1. Engine Oil
Drain all the oil from the crankcase while the engine is warm and refill with new oil to the upper Notch (full) on the engine oil dipstick. See Engine Oil Change in this manual.
2. Engine Oil Filter
Replace the engine oil filter. See Engine Oil Filter in this manual.
3. Transmission & Hydraulic System
 - (1) Transmission Oil
Check the level of the transmission oil. Add the specified fluid as needed to maintain proper level. See Transmission Oil Level (Gear Drive) or Transmission Oil Level (Hydrostatic Drive) in this manual.
 - (2) Hydrostatic System Filter (Hydrostatic Drive)
Replace the filter with a new one. See Hydrostatic System Filter in this manual.
 - (3) Hydraulic Filter
Replace filter with a new one. See Hydraulic Filter in this manual.
4. Front Axle Lubricant (MFD)
Change the oil. See FRONT AXLE LUBRICATION (MFD) in this manual.
5. Radiator Core
Inspect the radiator core and clean if necessary. See COOLING SYSTEM in this manual.
6. Hoses and Connections between Air Cleaner and Manifold.
Inspect for loose fit or leakage. See AIR INDUCTION SYSTEM in this manual.
7. Water Pump, Fan and Alternator Belt Tension.
Check the belt for tension, replace if necessary. See Fan Belt Adjustment in this manual.

LUBRICATION/FILTERS/FLUIDS

SYSTEM CAPACITIES

SYSTEM	U.S. MEASURE	METRIC MEASURE
Engine Oil	6.7 QTS	6.3 Liters
Fuel tank	7.7 Gallons	29 Liters
Coolant Engine and radiator (Only open model) Engine and radiator (Only CABIN model) coolant bottle	5.8 QTS 7.7 QTS 0.4 QTS	5.5 Liters 7.3 Liters 0.4 Liters
Transmission Oil gear drive hydrostatic drive	8.2 Gallons 8.7 Gallons	31 Liters 33 Liters
Front Axle MFD	4.9 QTS	4.6 Liters

LUBRICATION/FILTERS/FLUIDS

SERVICE POINT	NO OF POINTS	FREQUENCY IN HOURS					DESCRIPTION
		CHECK	CLEAN	CHANGE	GREASE	ADJUST	
Engine Oil Level	1	10					
Engine Oil	1			350 ^{*1}			*FIRST TIME-50 ^{*1} 350 hours or 2 years, whichever comes first*
Engine Oil Filter	1			350			FIRST TIME-50
Engine Valve Clearance (See Note 1)		1000					
Starter Moter		1000					
Fuel Filter (Main & Pre)	1			200			FIRST TIME-50
Air Induction Systems	1	200					
Air Cleaner Filter Element	1		10	200 ^{*2}			^{*2} 200 hours or yearly, whichever comes first
Radiator Coolant	1	10		Y			Coolant level
Grill and Radiator Area	1	DAILY	DAILY				
Fan Belt Tension	1	10					
Battery Water Level		10	AS NEEDED				
Battery Terminals			200				
Power Steering Cylinder End	1	50			10		No loose
Brake Pedal	2	DAILY				50	
Brake Pedal Boss	2				10		
Clutch Pedal	1	DAILY				50	
Clutch Pedal Boss	1				10		
Transmission Oil Level	1	10					
Transmission Oil	1			200 ^{*3}			*FIRST TIME-100 ^{*3} 200 hours or 2 years, whichever comes first*
Hydraulic System		AY					
Hydrostatic System Filter (Hydrostatic Drive)	1			300			FIRST TIME-50
Hydraulic Filter	1			300			FIRST TIME-50
MFD-Front Axle Lubricant	1			200			FIRST TIME-50
Tire Pressure	4	50					
Wheel Bolts Torque	24	100					FIRST TIME-50
Engine Frame Bolts Torque	16	50					FIRST TIME-10
ROPS Equipment		200					
All Linkage Pivot Points (See Note 2)	8		AY				
Threads of 3-Point Hitch Links	2				AY		
Compressor Belt Tension	1	100					
Cab Air Filter	1		10				
Front Axle Tie Rod End	2				10		

MARK

Y: Yearly or 1000 Hours, Whichever occur first.

AY: Yearly or as needed.

Note 1: Consult your Dealer.

Note 2: Apply gear oil.

LUBRICATION/FILTERS/FLUIDS

OIL SUPPLY , OIL LEVEL CHECK , GREASE SUPPLY , FILTERS CHANGE

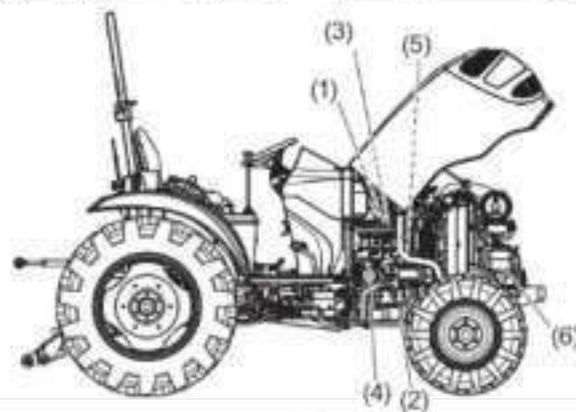
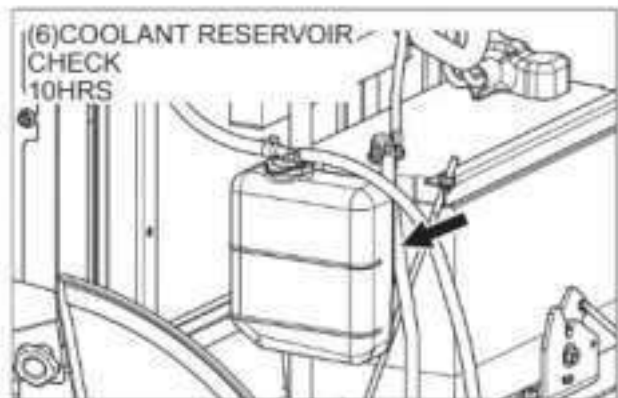
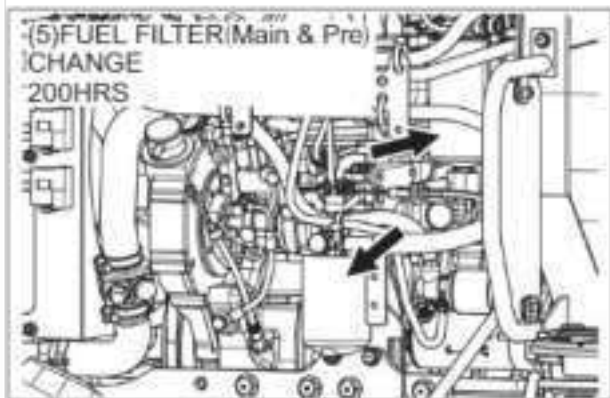
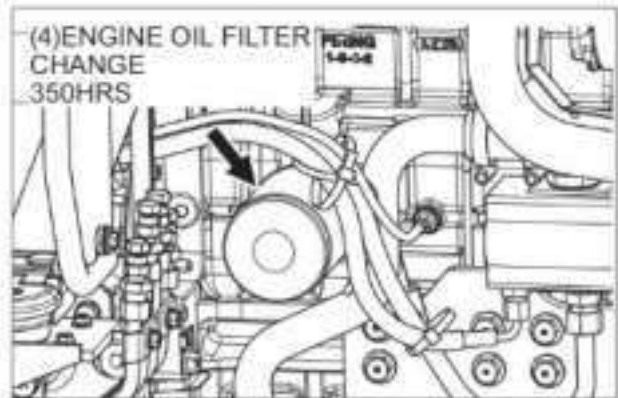
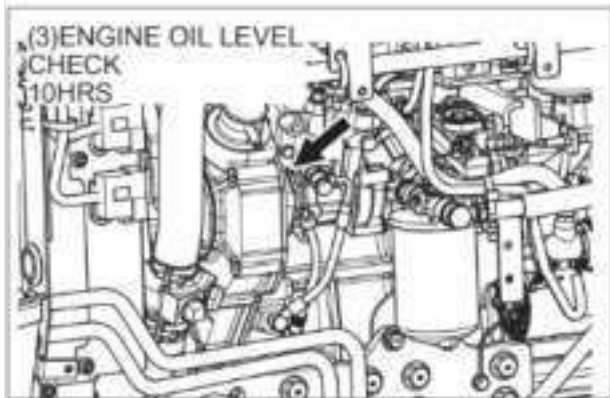
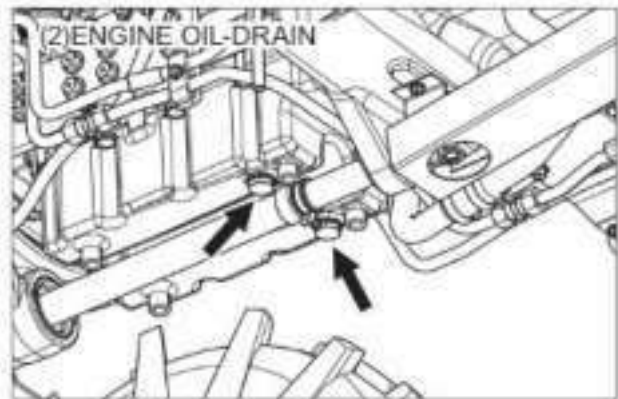
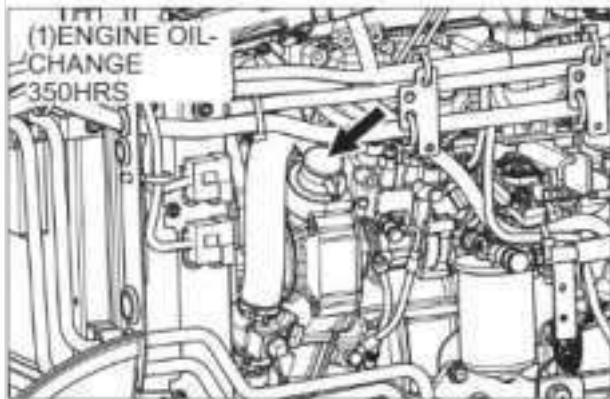

OIL SUPPLY , OIL LEVEL CHECK , GREASE SUPPLY , FILTERS CHANGE

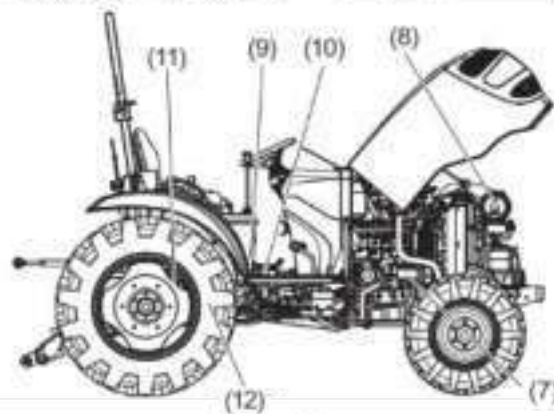
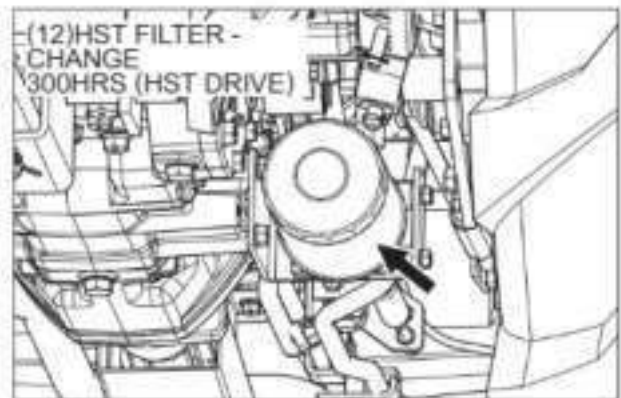
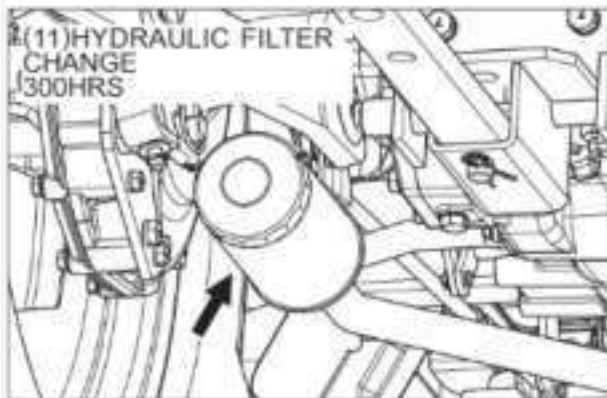
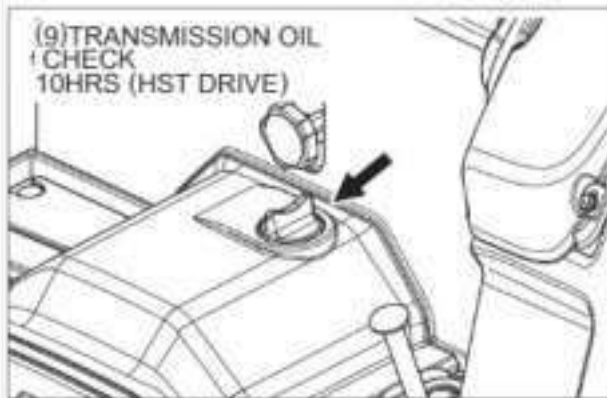
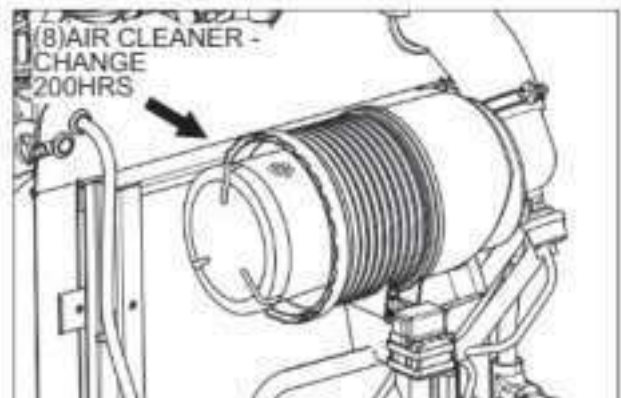
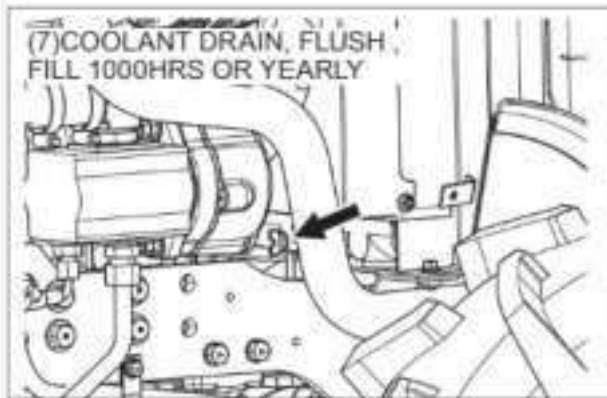

LUBRICATION/FILTERS/FLUIDS

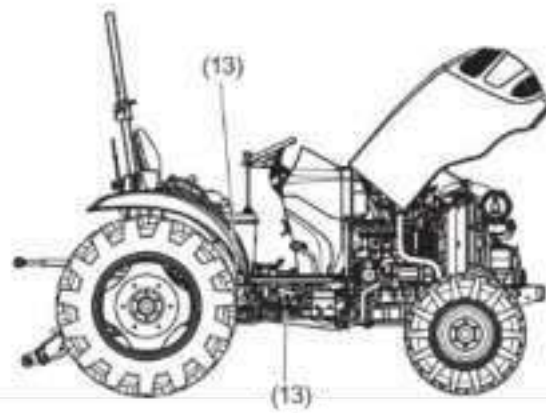
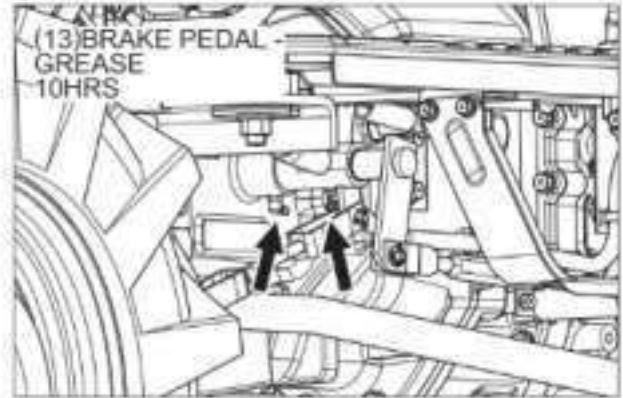
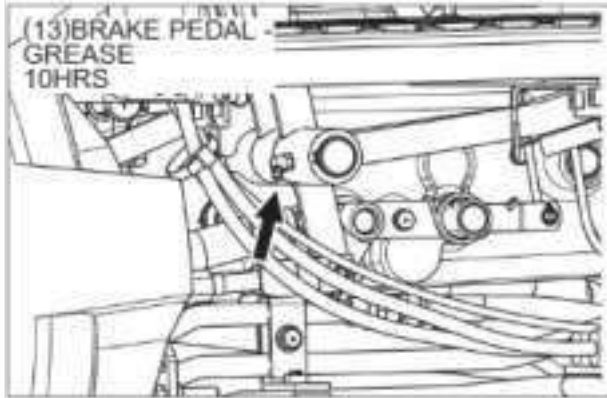

LUBRICATION/FILTERS/FLUIDS

(1) FRONT AXLE OIL - CHANGE
200HRS

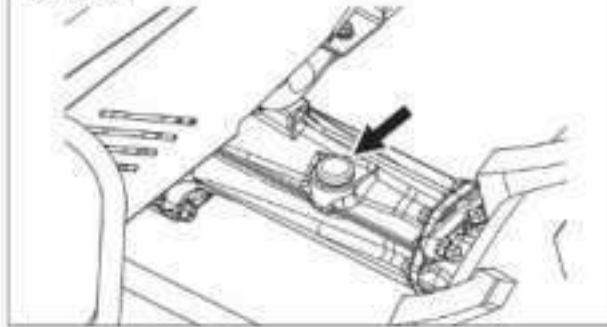

(2) FRONT AXLE OIL - DRAIN

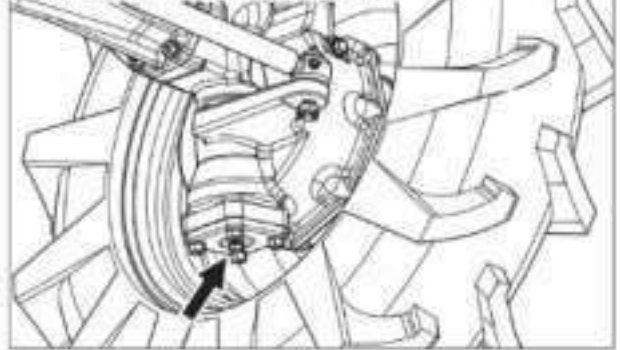

(3) FRONT AXLE OIL - CHECK

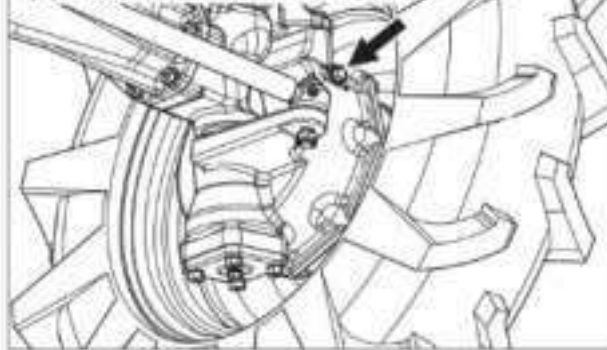

(4) POWER STEERING CYLINDER END
-GREASE
10HRS

(5) FRONT AXLE TIE ROD END GREASE
10HRS

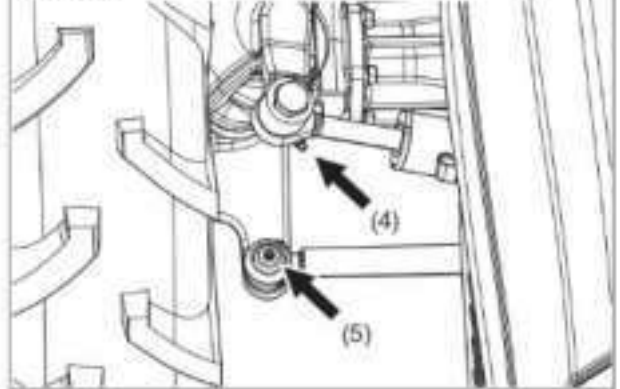

(6) ENGINE FRAME BOLTS -
CHECK
RH: EIGHT PIECES
50HRS

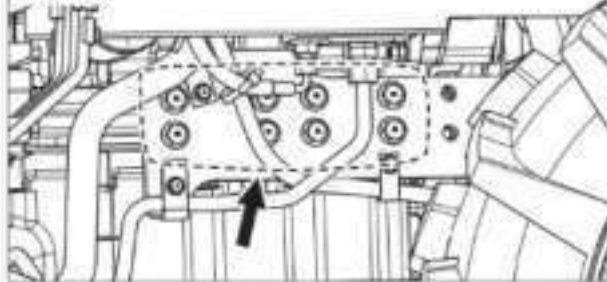

(7) ENGINE FRAME BOLTS -
CHECK
LH: EIGHT PIECES
50HRS

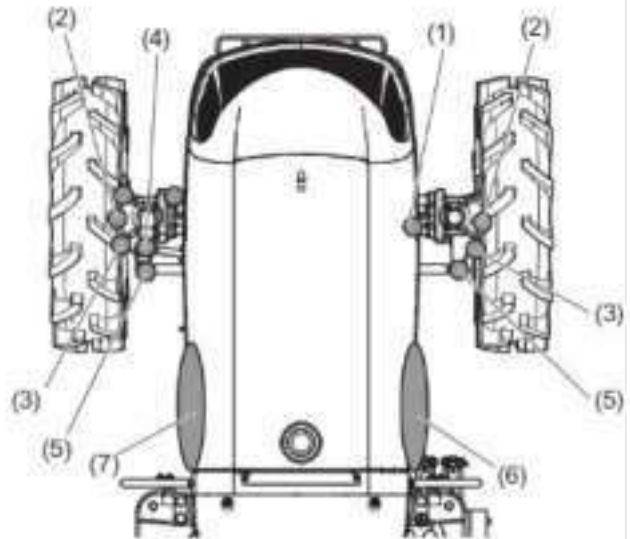
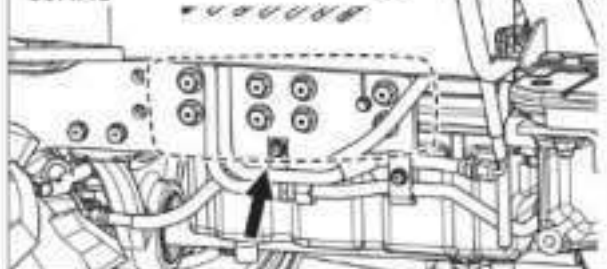

USE NLGI NO. 2 MULTIPURPOSE
LITHIUM GREASE.

ENGINE LUBRICATION

Service Specifications

Oil Level Check Interval.....	Every 10 hours
Oil Change Interval.....	Every 350 hours (See NOTE)
Oil Type	See Lubrication Table in this manual.
Oil Capacity	6.3 Liters (6.7 QTS)

NOTE: Change the engine oil after the first 50 hours of operation and then use the regular change interval. Change the engine oil more frequently when the operating conditions are severe, such as, operating in very high or very low ambient temperatures, very dusty.

Engine Oil Level

To check the engine oil level, put the tractor on level ground and stop the engine. Pull the dipstick out, wipe the dipstick with a dry cloth and install the dipstick to check the oil level. If the oil level is below the A (Add) mark, add oil to raise the oil level to the F (Full) mark. Do not raise the oil level above the F (Full) mark.

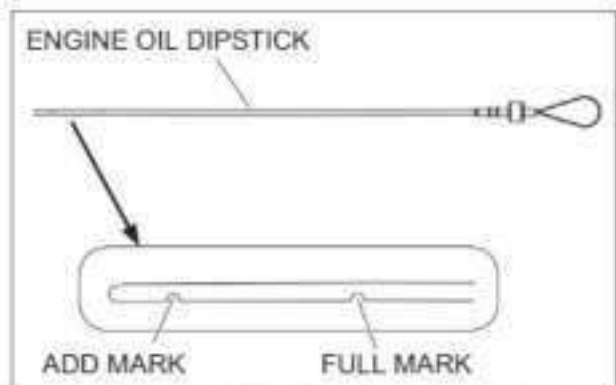
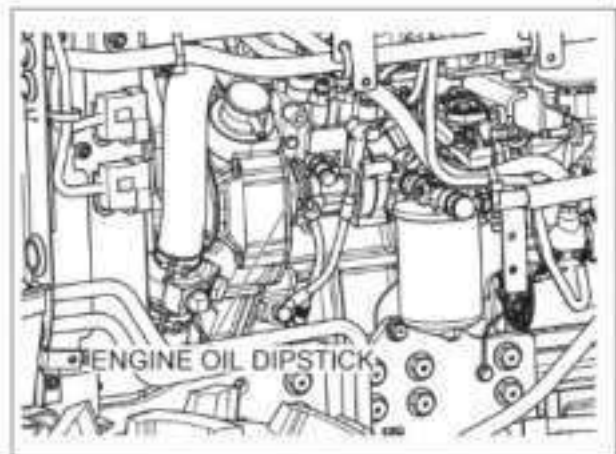

IMPORTANT: The level should be checked before starting or 5 minutes after the engine has been shut off.

Engine Oil Change

To change the engine oil, put the tractor on level ground and stop the engine. Change the engine oil as follows:

NOTE: For best results change the oil while the engine is still warm.

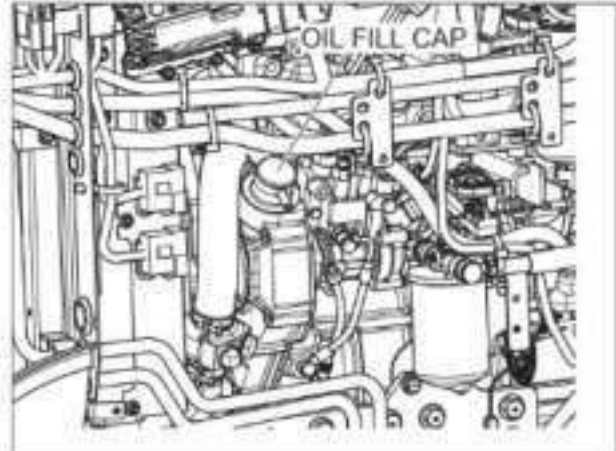
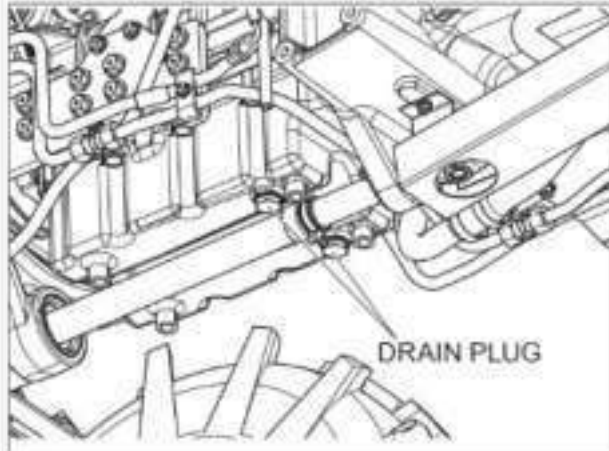

1. Remove the oil pan drain plug and drain the oil from the engine.
2. See Engine Oil Filter in this manual, if the filter needs to be changed.
3. Install the drain plug in the oil pan. Tighten the plug to a torque of 30 to 40 Nm (22 to 29 Lbf).
4. Put the correct type and amount of new oil into the engine. See Engine Oil Selection in this manual for the recommendation of oil type.

IMPORTANT: Do not use the oil level dipstick as a guide when you fill the oil to engine crankcase. Always measure the amount of oil you install.

5. Start the engine. Operate the engine for five minutes at 1200 rpm.
Check for oil leaks at the filter base and drain plug.
6. Stop the engine. Wait approximately five minutes for the oil return to the oil pan. Check the oil level on the dipstick and add oil if needed.

LUBRICATION/FILTERS/FLUIDS

Engine Oil Filter

Change Interval..... Every 350 hours (See NOTE)

NOTE: Change the engine oil filter after the first 50 hours of operation and then use the regular change interval.

IMPORTANT: Change the oil filter at the recommended time interval. Your Dealer has approved genuine filters. Do not use other type filters.

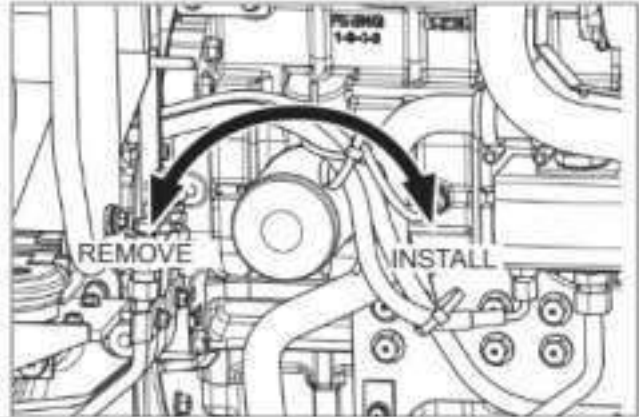

Change the engine oil filter as follows:

1. Drain the oil from the engine. See Engine Oil Change in this manual.
2. Turn the oil filter counterclockwise to remove. Use a filter wrench, if necessary.
3. Apply clean oil to the O-ring on the new filter.
4. Install the filter. Turn the filter until the O-ring comes in contact with the case surface. Tighten the filter an additional 2/3 turns by hand.

IMPORTANT: DO NOT use a filter wrench to install the oil filter. When the filter is too tight, you can cause damage to the O-ring and filter.

5. Put new oil in the engine. See Engine Oil change in this manual.

COOLING SYSTEM

Service Specifications

Coolant Change Interval..... Every 1000 hours or once per each year whichever occurs first.

Capacity of System

Engine and Radiator (Only open type).....	5.5 Liters (5.8 QTS)
Engine and Radiator (Only CABIN type)	7.3 Liters (7.7 QTS)
Coolant reserve bottle.....	0.4 Liters (0.4 QTS)

Thermostat..... 80°C to 96°C (176°F to 204.8°F)

Radiator Cap Pressure 88 kPa (12.8 psi)

Daily before starting the engine, check the coolant level the coolant reserve bottle. The coolant level should be between the "FULL" and "LOW" lines when the engine is cool.

Pressure Cooling System



Check and service cooling system according to maintenance instructions. Hot coolant can spray out if radiator cap is removed while system is hot. To remove radiator cap, let system cool, turn to first notch, and then wait until all pressure is released. Scalding can result from fast removal of radiator cap.

1. The pressure cap on a pressure cooling system has a control valve that operates as a SAFETY RELIEF VALVE to keep the pressure within the system operating range. Operating the engine without a pressure cap or with a pressure cap but not setting value to operate at the correct pressure can cause damage.

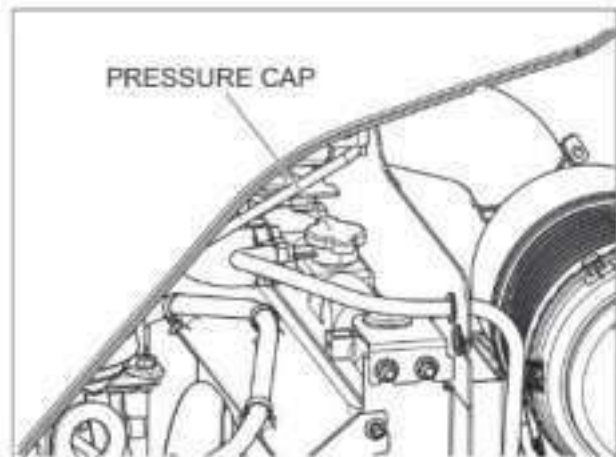

2. A pressure cooling system decreases the loss of coolant caused by evaporation or boiling. The system must have good seals at the radiator cap, hoses and hose connections. It is important that you stop ALL LEAKS OF ANY SIZE as soon as the leaks are found. A small leak can become a large flow when pressure is increased in the cooling system. While the tractor is in operation, a weak hose can break and cause injury or damage. Check all hoses and hose connections with frequency. KEEP HOSES, HOSE CONNECTIONS AND PRESSURE CAP IN GOOD CONDITION.

Coolant Solutions

Your tractor cooling system is equipped with an ethylene glycol coolant solution that has a high boiling point.

IMPORTANT: Change the coolant solution at the change interval recommended in this manual (See Lubrication and service Chart). The heat generated by the diesel engine causes a natural change in the inhibitors in the coolant, which results in loss of corrosion protection. The loss of the inhibitors may cause water pump cavitations and cylinder block erosion.

Install only ethylene glycol coolant solution in the cooling system. Use a good quality, high boiling point, ethylene glycol that does not have any additives to stop leaks. Do not install any rust inhibitors that are not approved. It is possible that the rust inhibitors and ethylene glycol will not mix and work against each other to decrease corrosion protection, from deposits in the cooling system and cause damage to the cooling system and the radiator.

Do not use a low boiling point, alcohol type coolant solution.

The boiling point of alcohol is below the tractor minimum operating temperature; loss of coolant due to evaporation will result.

IMPORTANT: Always have a minimum of 50 percent ethylene glycol coolant in the cooling system at all times and at all ambient temperature ranges. Do not install more than 50 percent ethylene glycol in the cooling system unless the ambient air temperature will be less than -34°F . More than 50 percent ethylene glycol decreases heat transfer and will cause the engine surface temperature to be higher than normal.

Cleaning The Cooling System

IMPORTANT: NEVER PUT COOLANT IN A HOT ENGINE: THE ENGINE BLOCK OR CYLINDER HEADS CAN GET CRACKS BECAUSE OF THE DIFFERENCE IN TEMPERATURE BETWEEN THE METAL AND THE COOLANT.

Clean the cooling system each time when the coolant is changed. See the Lubrication and Service Chart in this manual for recommended change intervals. Clean the system as follows:

1. Turn on the plug to drain the coolant. Turn off the plug after the system is empty.
2. Install a good type of radiator cleaner and fill the system with clean water. Follow the instructions given with the radiator cleaner.
3. Remove the radiator cleaner solution. Flush the system with clean water.
4. Fill the cooling system with the coolant solution specified in this manual. Install coolant system treatment (if required). See Coolant Solutions in this manual for more information. (P95)
5. Check the hoses, radiator, pump and water manifold for leaks.

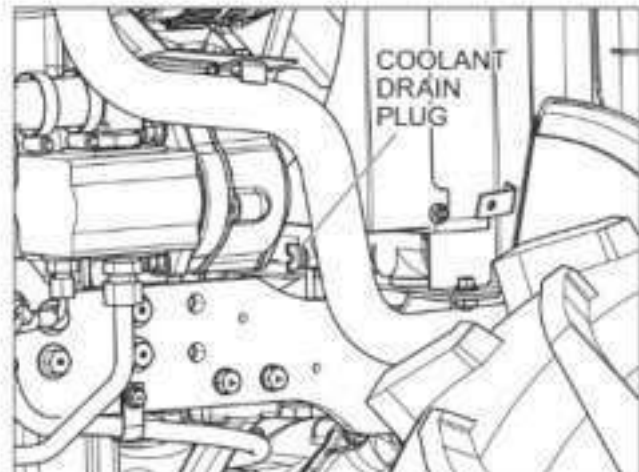
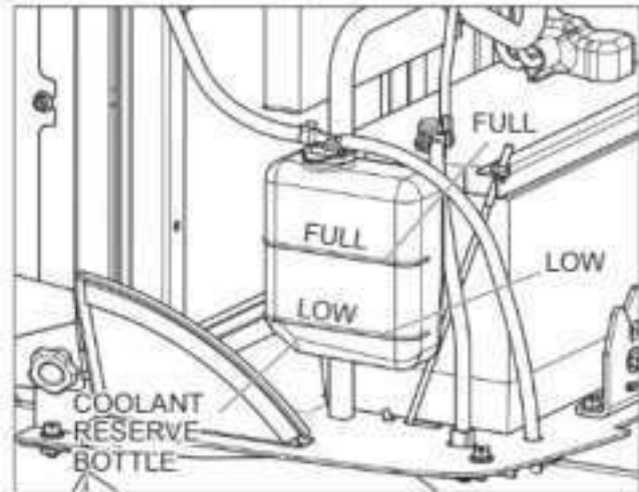

IMPORTANT: Never drain the coolant when the engine is hot.

NOTE: After the cooling system is completely filled, run the engine for approximately five minutes to remove all air from the system. Check the coolant level and add coolant if needed.

FUEL SYSTEM

Service Specifications

Fuel Filter Element Change..... Replace when loss of power or misfiring occurs

This type of filter cannot be cleaned. Change the filter when the engine is misfiring or a loss of power is evident. It is necessary to remove the air from the system after each replacement.

Only a filter recommended by your Dealer should be used to be sure that it is both effective and capable of withstanding the required suction or pressure without damage to the filter element.

Fill the fuel tank at the end of each day to reduce condensation.

NOTE: Do not fill the fuel tank to its full capacity. Space is required for vapor expansion in the event of a temperature change. A tank filled to capacity may overflow if exposed to a rise in temperature or direct sunlight.

Water Removal from the Filter

If fuel main-filter indicator illuminates, drain off the water as follows :

1. Pull out the coupler from the water level sensor
2. Turn the water level sensor counterclockwise to remove.
3. After drain water, install the water level sensor and tighten to a torque of 2 N•m(1.5Lb ft)
4. Connect the coupler to the water level sensor.
5. Push the hand primer several times until it is difficult to push.

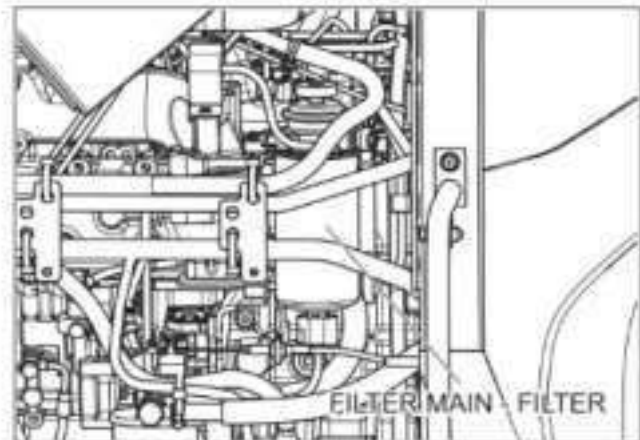

NOTE : Drain water once in a week or earlier if water contamination is excessive. Continued driving with water accumulation in fuel filter will cause damage to fuel pump / other fuel system components.

NOTE : Replace fuel filter at the recommended period or whenever it gets clogged. Discard the old filter and do not repair or clean the filter. Always fit the spin-on filter dry.

Main Fuel Filter Element Replacement

To replace the filter element, use following procedure:

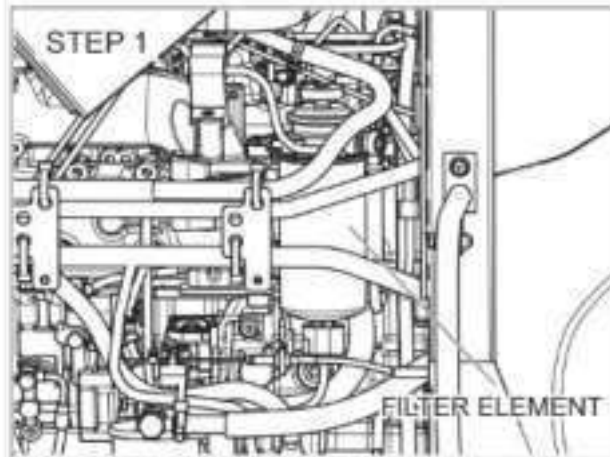

Clean the outside of the filter element to prevent dirt or foreign materials from entering into the system.

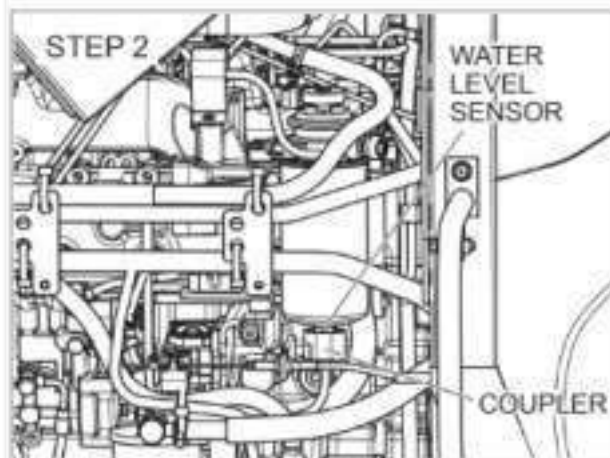

Pull out the coupler from the water level sensor, and turn the water level sensor counter clockwise to remove.

Remove the filter element by turning it counter clockwise.

STEP 3

Apply film of fuel to the gasket. Install the new filter element by hand up to the base, and tighten by hand to +270°

IMPORTANT: Do not use a filter wrench to install the filter element.

STEP 4

Install the water level sensor and tighten to a torque of 2 N•m(1.5Lb ft).

Connect the coupler to the water level sensor.

STEP 5

Push the hand primer several times until it is difficult to push.

STEP 6

Clean off the fuel from the engine. Start the engine to check for fuel leaks around the filter, lines and fittings.

NOTE: If the engine does not have power with a full load after you have done the filter service and removed the air from the system, see your Dealer to find and correct the cause.

LUBRICATION/FILTERS/FLUIDS

Pre Fuel Filter Element Replacement

To replace the filter element, use following procedure:

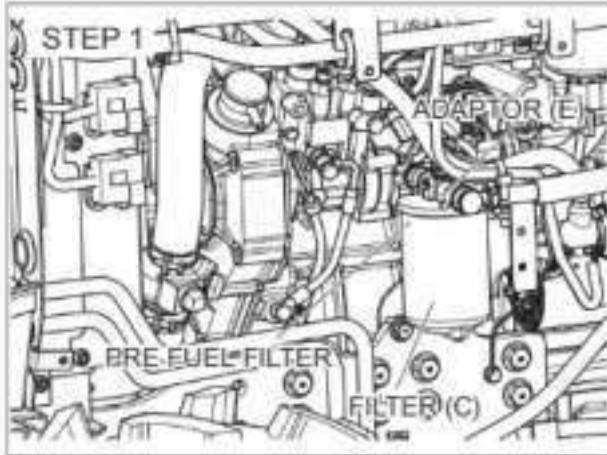

To remove filter, unscrew the filter (C) from adaptor (E).

STEP 2

Check O-rings of fuel filter for any crack / damage. Smear oil on the new O-ring before installation.

STEP3

Clean the adaptor with clean diesel from inlet and outlet. Ensure no dirt, foreign particles entangled in flap valves or filter head.

STEP4

Assmble the new filter. Do not over tighten.

Fuel System Air Removal

AIR MUST BE REMOVED FROM THE FUEL SYSTEM.

AIR CAN ENTER THE FUEL SYSTEM WHEN:

1. The engine stopped caused from lack of fuel.
2. The fuel filter has been replaced.
3. Any connections between the injection pump and fuel tank have been loosened or disconnected for any reasons.
4. The tractor has not been operated for long time.
5. The fuel pump has not operated correctly.

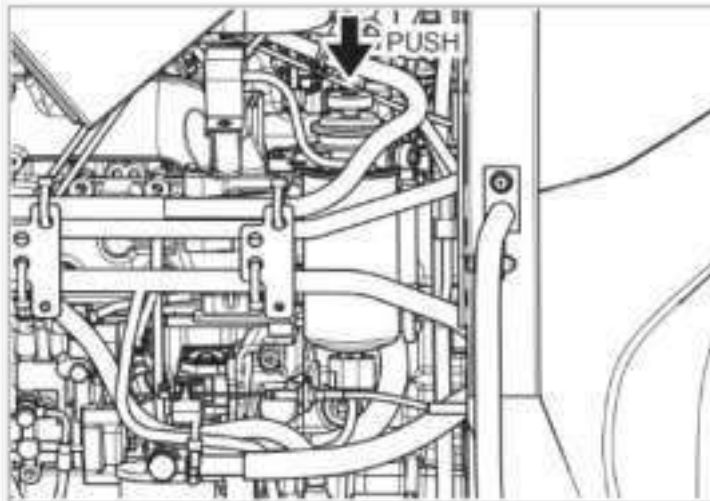

Push the hand primer several times until it is difficult to push.

LUBRICATION/FILTERS/FLUIDS

Fuel Injection Pump and Nozzle Check

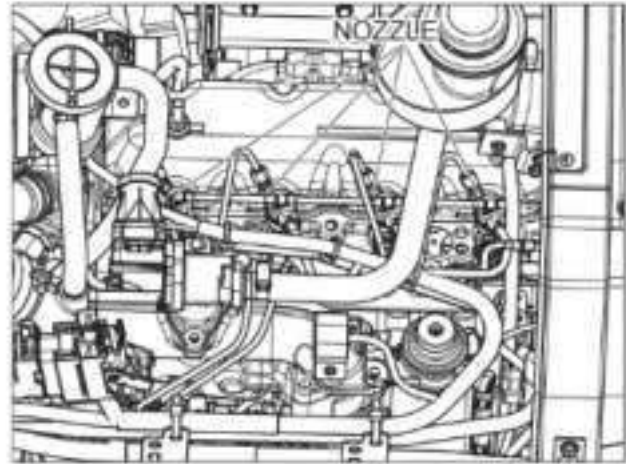
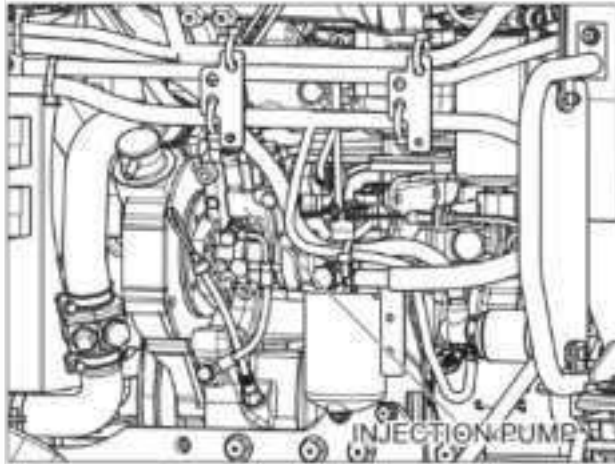

NOTE: Figure of the engine Unit

The fuel injection pump and nozzles are precision units and must be serviced only by your dealer.

The injection pump is correctly set and sealed at the factory and should not require an adjustment. Whenever adjustment or repairs are necessary, see your dealer. Do not tamper with any of the pump units.



Hydraulic oil or diesel fuel leaking under pressure can penetrate the skin and cause injection or other injury.

To Prevent Personal Injury:

Relieve all pressure, before disconnecting fluid lines.

Before applying pressure, make sure all connections are tight and components are in good condition.

Never use your hand to check for suspected leaks under pressure.

Use a piece of cardboard or wood for this purpose.

If injured by leaking fluid, see your doctor immediately.

AIR INDUCTION SYSTEM

The air induction system components require service at different intervals according to local operating conditions.

Service Specifications

Dump Valve..... Clean daily or every 10 hours

Filter Element

Clean Element..... When necessary

Replace ElementAfter 10 cleanings or When necessary or yearly

System Inspection..... Every 200 hours or yearly whichever occurs first

Your tractor is equipped with a dry-type air cleaner with a replaceable element.

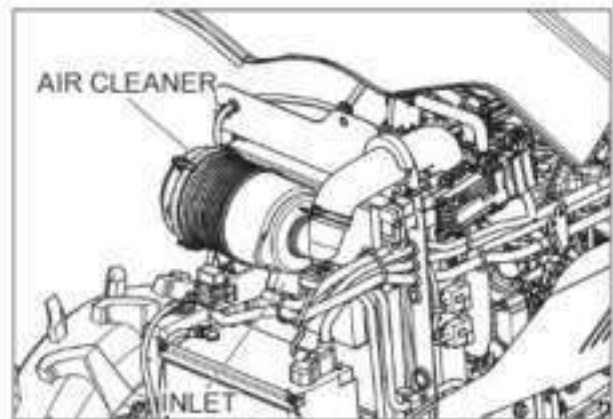

IMPORTANT: Service the air induction system at the given service intervals. Correct maintenance will make longer life of the engine. Keep all connections on the outlet hose tight.

Dump Valve

The dust in the filter case should be dumped daily by using the dump valve when operating in extremely dusty conditions.

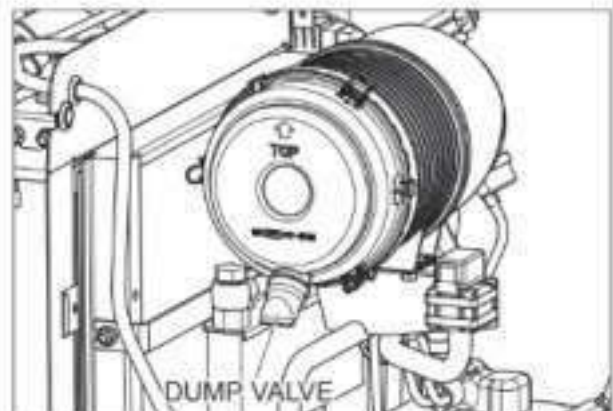

LUBRICATION/FILTERS/FLUIDS

Air Filter Element Removal

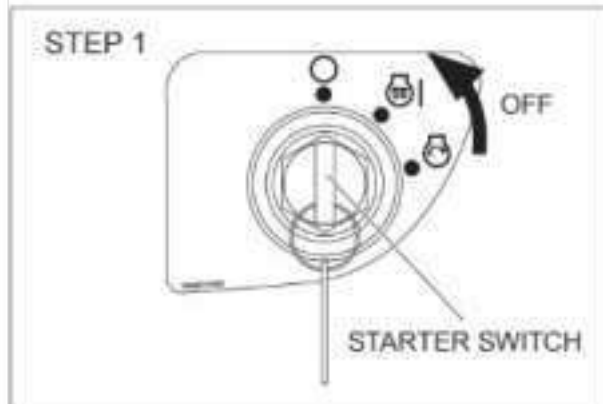

Stop the engine.

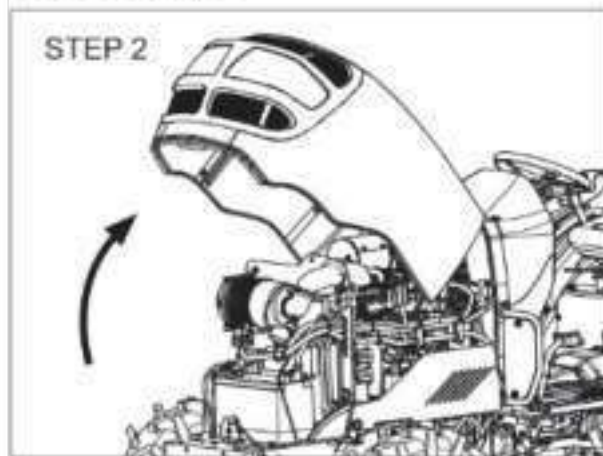

Open the hood.

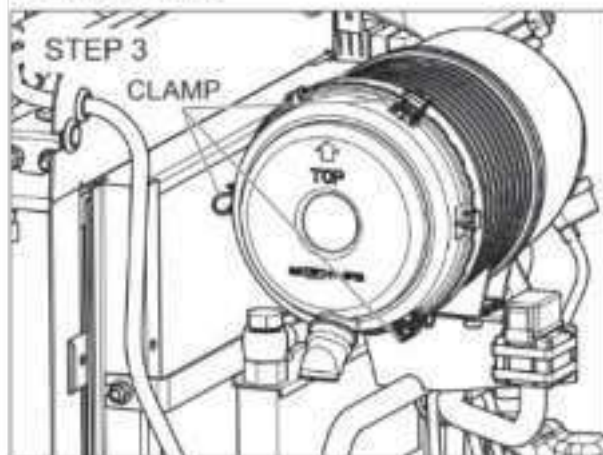

When servicing the air filter element, unhook the clamp and remove element by pulling it straight out very carefully. Clean interior of canister.

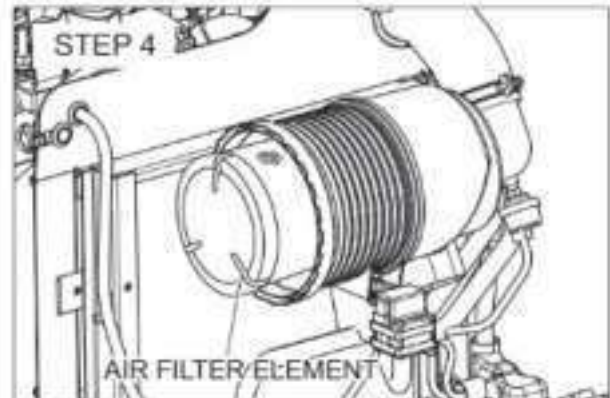

After replacing the new or cleaned element, install and hook the clamp.

NOTE: Never attempt to remove the element from the air cleaner while the engine is running.

When installing the element, inspect the element gasket. If the gasket or element surface is damaged, replace the element immediately.



Element Cleaning

Use clean, dry compressed air up and down the pleats on the clean side (inside) of the element.

Continue this until the element is clean.



NOTE:

1. The paper element must be handled with care. Do not hit the element against a hard surface.
2. Air pressure at the nozzle must not exceed 689 kPa (100 psi).
3. It may be necessary to replace the element sooner if the time interval between servicing becomes short indicating the element does not respond to cleaning (soot contaminated).

System Inspection

Check the dump valve and the all hoses for cracks and wear. Replace if needed. All the connections on the hoses must be tight. All the gaskets must be in good condition and the bolts must be drawn up tight.

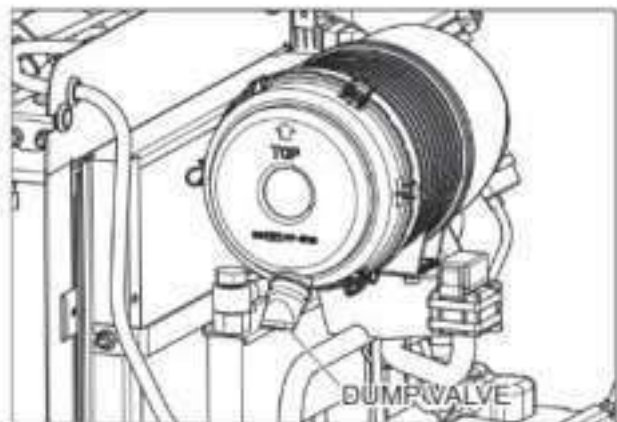

NOTE: Inspect the hoses and connections after the first 50 hours of operation and replace when necessary.

TRANSMISSION & HYDRAULIC LUBRICATION

Service Specifications

Oil Level Check Interval.....	Every 10 hours.
Oil Change Interval.....	Every 200 hours.
Oil Capacity	
Gear Drive	31 Liters (8.2 Gallons).
Hydrostatic Drive	33 Liters (8.7 Gallons).
Oil Type	
Gear Drive	HYDRAULIC TRANSMISSION FLUID
Hydrostatic Drive	HYDRAULIC TRANSMISSION FLUID
Hydraulic System Check.....	Yearly inspect for leaks, cracks and abrasion. Tighten fittings or replace as needed.

Transmission Oil Level (Gear Drive)

To check the transmission fluid level, put the tractor on level ground.

Unscrew the filler cap with dipstick and wipe it clean. Check fluid by dipstick level, Do not screw in cap when checking. If the fluid level is below the lower line of the dipstick, add the recommended fluid to raise the fluid level between the F (Full) and L (Low) marked position.

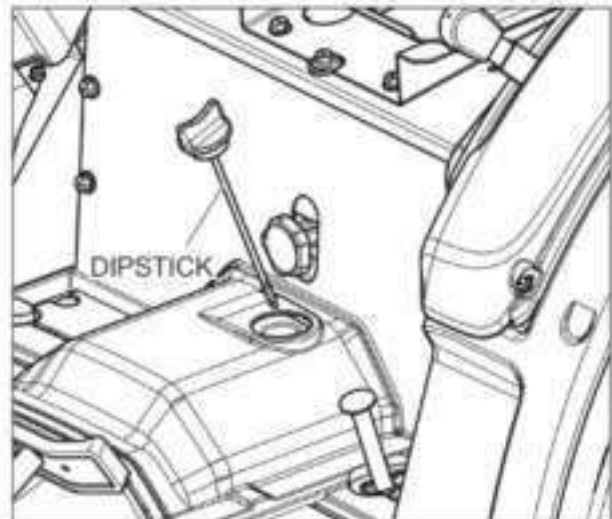

Transmission Oil Level (Hydrostatic Drive)

Before checking the oil level of the hydrostatic drive tractor, run the engine for three to five minutes at 1500 RPM with the speed ratio control lever, range shift lever and PTO control lever in Neutral or OFF position. Afterwards, stop engine. Then check the oil level in the transmission.

To check the transmission oil level, put the tractor on level ground.

Check the oil level on the transmission dipstick. If the oil level is below the lower line of the dipstick, add the recommended oil to the transmission to raise the oil level to the F (FULL) marked position.

Transmission Oil Change

Oil Change Interval..... Every 200 hours

To change the transmission oil, use the following procedure:

1. Put the tractor on level ground, apply the park brake and stop the engine. Move the range shift lever to L position.
2. Remove the drain plugs from the transmission case. (5 pieces)

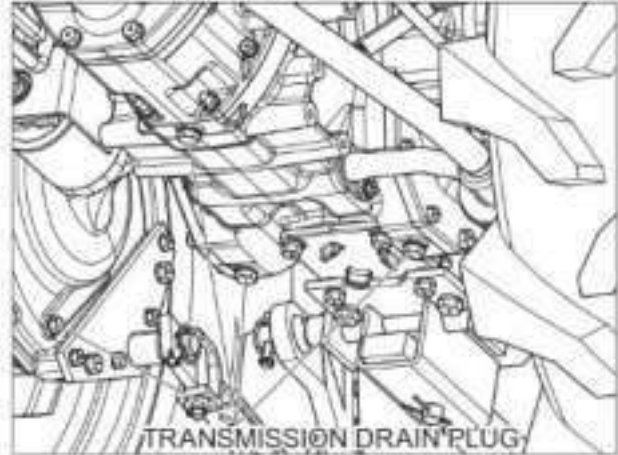

NOTE: For best results, drain the oil when the oil is warm.

3. Replace the hydraulic filter. See Hydraulic Filter in this manual.
4. For the hydrostatic drive tractor, replace hydrostatic filter if needed, See Hydrostatic Filter (Hydrostatic Drive) in this manual.
5. Install the drain plugs with a seal washer and tighten to a torque of 39 to 44 Nm (29 to 33 Lbft).

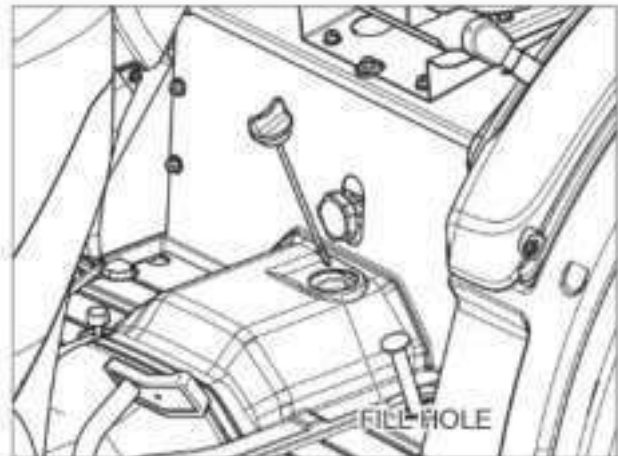

6. Add the recommended oil through the fill hole and check the oil level.
7. Start the engine and check for leaks.
8. Recheck the oil level after stopping the engine. If the oil level is low, add oil up to the specified level.

LUBRICATION/FILTERS/FLUIDS

Hydraulic Filter (Gear & Hydrostatic Drive)

Change Interval..... Every 300 hours (See NOTE)

NOTE: Replace the hydraulic filter after the first 100 hours of operation and every 300 hours of operation thereafter. Your Dealer has approved genuine filters. Do not use other type filters.

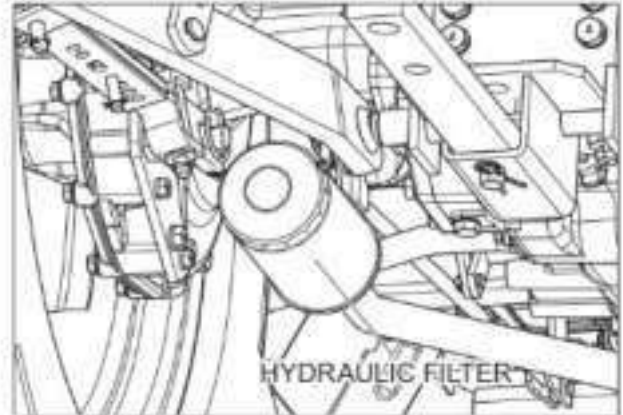

CHANGE THE HYDRAULIC FILTER AS FOLLOWS:

1. Put the tractor on level ground, move the range shift lever to the L position and apply the park brake.
2. Put an oil canister under the hydraulic filter.
3. Turn the filter counterclockwise to remove. Use a filter wrench if needed.
4. Apply clean oil to the O-ring on the new filter.
5. Install the filter. Turn the filter until the O-ring comes in contact with the case surface. Tighten the filter an additional 2/3 turns by hand.

IMPORTANT: DO NOT use a filter wrench to install the hydraulic filter. When the filter is too tight, you can cause damage to the O-ring and filter.

6. Wipe around the hydraulic filter with a dry cloth.
7. Change the transmission oil. See Transmission Oil Change in this manual.

Hydrostatic System Filter (Hydrostatic Drive)

Filter Change Interval... Every 300 hours (See NOTE)

NOTE: Change the filter after the first 100 hours of operation and every 300 hours of operation thereafter. Replace the filter more frequently when operating under unusual dirt and dust conditions. Your Dealer has approved genuine filters. Do not use other type filters.

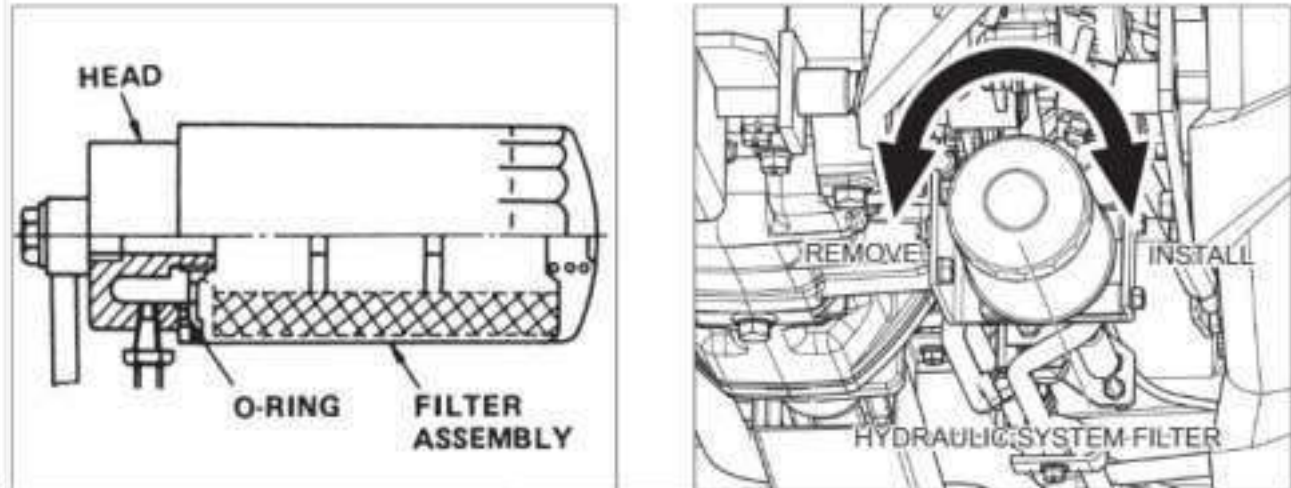

When the transmission oil filter needs changing, change the filter as follows:

1. Drain the transmission oil. See Transmission Oil Change in this manual.
2. Remove the hydrostatic system filter by turning it counterclockwise. Use a filter wrench, if necessary.
3. Apply clean oil to the O-ring on the new filter.
4. Install the new filter. Turn the filter clockwise until the O-ring comes in contact with the filter head surface. Tighten the filter an additional 2/3 turns by hand.
5. Add the transmission oil through the fill port and check the oil level.
6. Run the engine and check for leaks.
7. After stopping the engine, check the oil level. If it is low, add clean oil.

FRONT AXLE LUBRICATION (MFD)

Service Specifications

Oil Change Interval.....	Every 200 hours (See NOTE)
Oil Capacity.....	4.6 Liters (4.9 Quarts)
Oil Type	Hydraulic Transmission Fluid

NOTE: Change the oil after the first 50 hours of operation and then every 200 hours of operation.

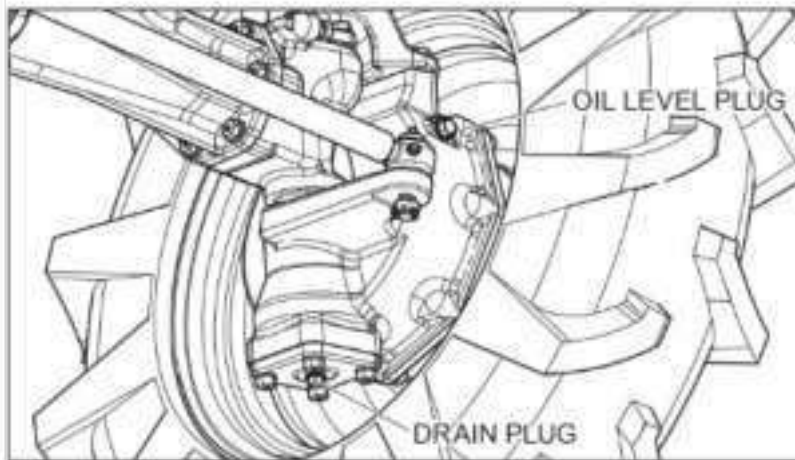

To check the front axle oil level, put the tractor on level ground. Remove the oil level plugs located on the rear of the both gear cases. If the oil level is low, add the recommended oil type through the fill hole located on the RH side of axle housing until the oil begins to flow out of the level plugholes.

Front Axle Oil Change

1. To change the front axle oil, put the tractor on level ground. Put the range lever in L, engage the park brake and stop the engine.

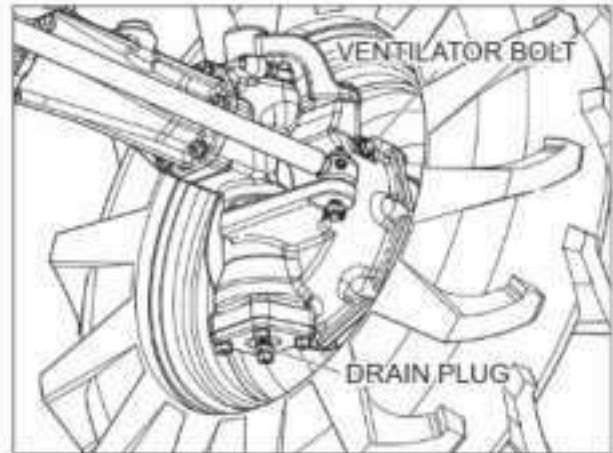
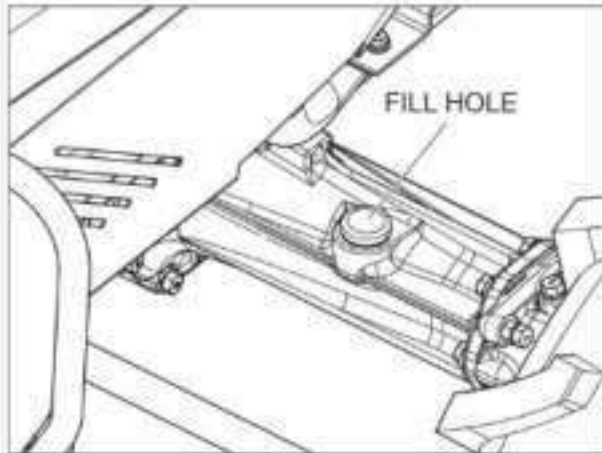

2. Remove the fill cap located on the axle housing, the front axle drain plugs located on the bottom of both side gear cases to drain the oil.

NOTE: For best results, drain the oil when the oil is warm.

3. Install the both front axle drain plugs. Supply the oil of the specified quantity.
Remove the ventilator bolt of right side and left side.
Tighten the ventilator bolt, after oil flows out.
(During 20 seconds, oil flows out after having removed a ventilator bolt.)
Afterwards, remove the oil level plug and confirm that oil flows out.
Finally, tighten the oil level check bolt.

COOLING SYSTEM

Grill Screens and Radiator Area

Grille Screens and Radiator Area

Service Interval..... Every 50 hours or more frequently if required.

To clean the radiator screen, put the tractor on level ground, apply the park brake and stop the engine.

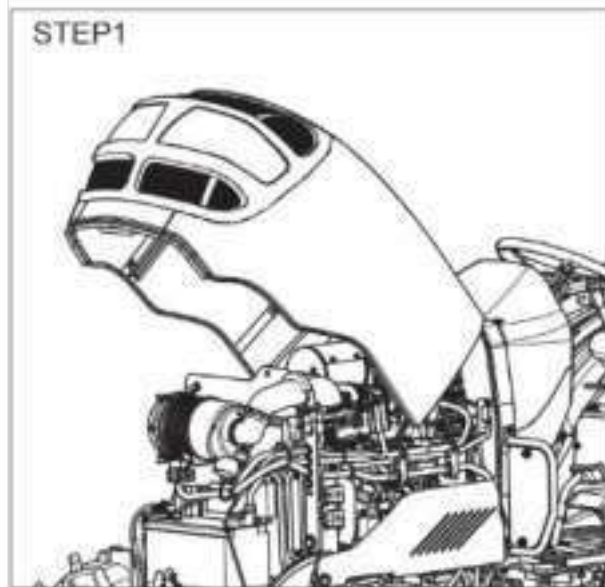

Open the hood.

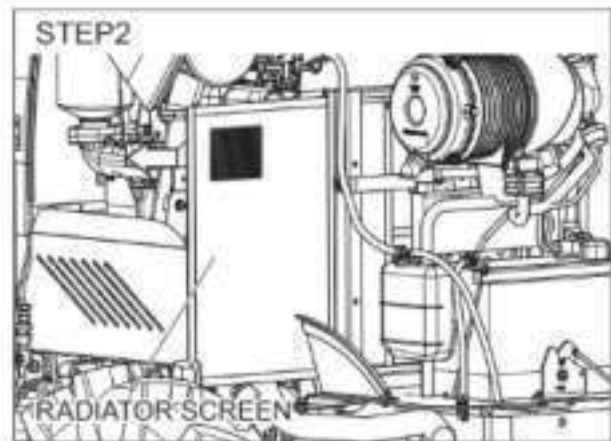

Lift the radiator screen.

STEP3

Clean the radiator screen and the surrounding area.

STEP4

Install the radiator screen.
Lower the hood.

Fan Belt Adjustment

Fan Belt Tension Check Interval..... 10 Hours

NOTE: Adjust the belt tension after the first 50 hours of operation and replace when if needed.

Measure the fan belt for correct tension. Check to see if the belt deflection is about 7 ~ 10mm (0.25 ~ 0.4 inch) at point (A).

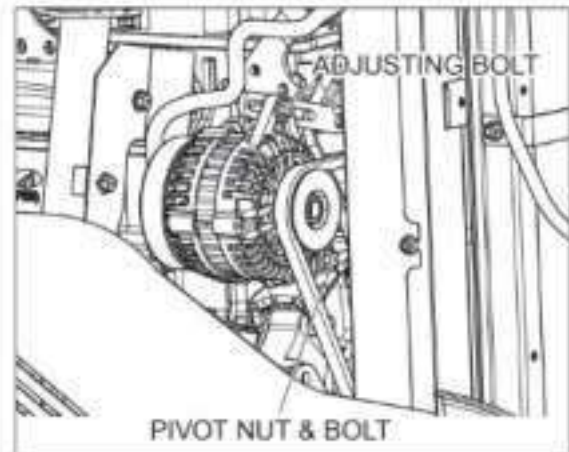
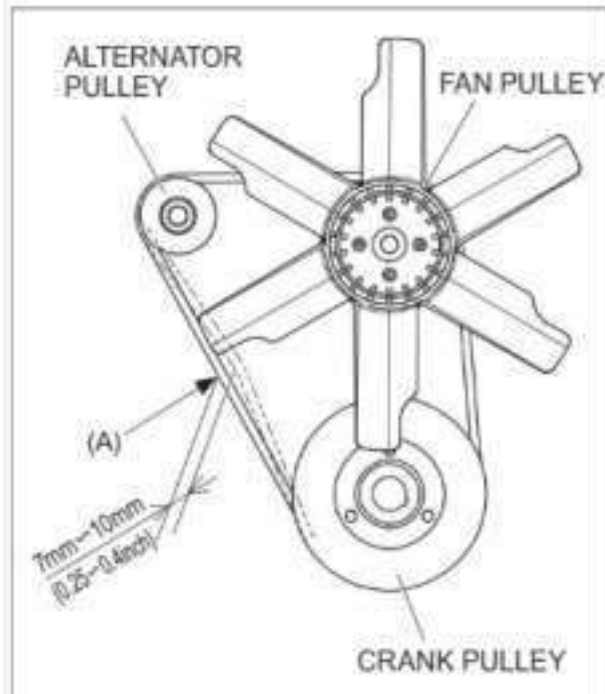

Rotating fan and belts. Contact can injure. Keep clear.

To adjust the fan belt tension, loosen the adjusting bolt and pivot nut of the alternator. Move the alternator away from the engine until as shown above. Tighten the adjusting bolt and pivot nut to a torque of 16 Nm (12 Lbft).

NOTE: Too high tension will cause alternator and water pump bearing failure and belt wear. Too low tension will cause a decrease in alternator output and belt wear.

MAINTENANCE/ADJUSTMENT

Fan Belt Replacement

To replace the fan belt, use following procedure:

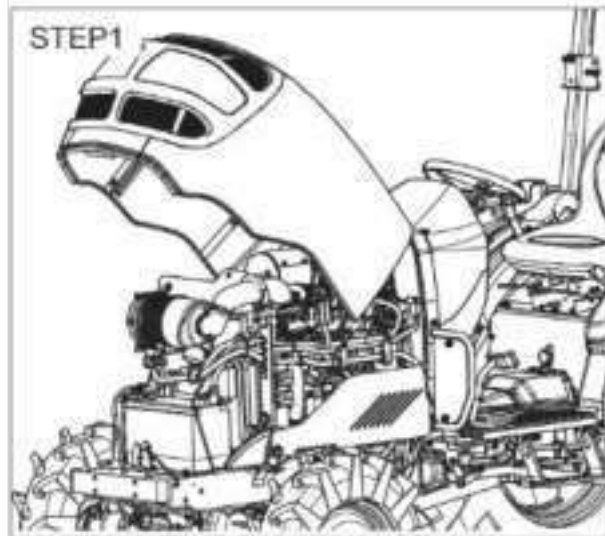

Open Bonnet.

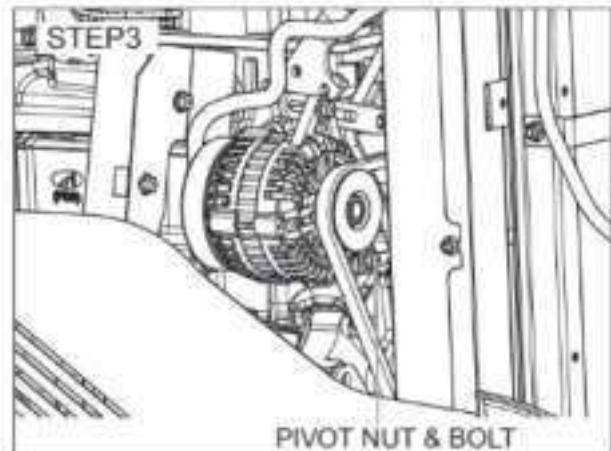

Loosen the alternator pivot nut and push the alternator toward the engine to remove the belt.

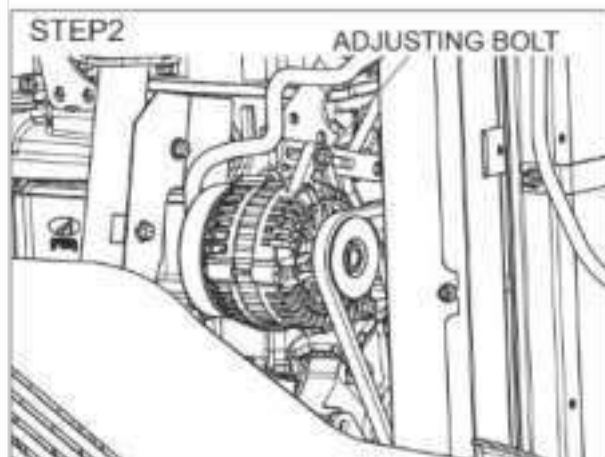

Loosen the alternator-adjusting bolt.

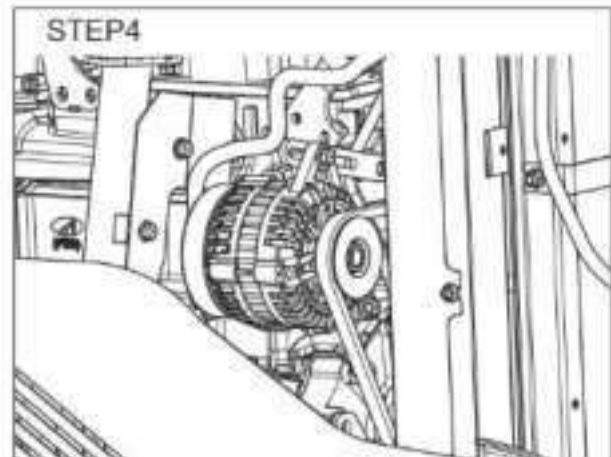

Install new fan belt and adjust the belt tension. See Fan Belt Adjustment in this manual for instructions.

CLUTCH PEDAL ADJUSTMENT

Service Specifications

Clutch Pedal Check and Adjustment Interval.....	Every 50 hours of operation or yearly
Free Pedal Movement.....	20-30mm (0.8-1.2 inch)

Free Movement Adjustment

Clutch pedal free movement is very important and must be checked at the recommended intervals. If there is no free movement, the clutch disc will wear quickly. If there is too much free movement, the clutch will not disengage correctly and the transmission will be difficult to shift.

1. Put the tractor on level ground, move the range shift lever in the L position, apply the park brake, stop the engine and adjust the clutch pedal free movement as follows.

2. Push the clutch pedal down by hand, to measure the amount of pedal free movement.

3. The pedal free movement must be within the specification shown above.

4. Loosen the lock nut.

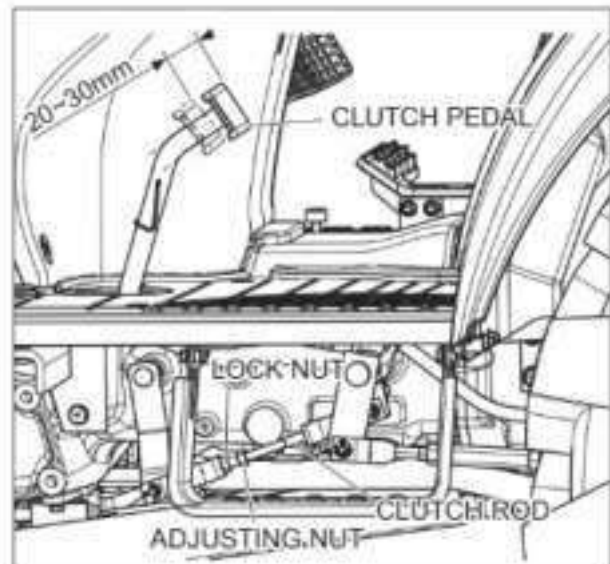

5. Adjust the pedal free movement as necessary with the adjusting nuts on the clutch rod.

6. To increase free movement, turn the nuts at inside.

7. To decrease free movement, turn the nuts at outside.

8. Tighten the lock nuts to the torque of 44 to 54 Nm (32 to 40 Lbft).

BRAKE PEDAL ADJUSTMENT

Service Specifications

Brake Pedal Check and Adjustment Interval... Every 50 hours or yearly

Free Pedal Movement Specification... 35 to 45mm (1.38 to 1.77inch)

Brake pedal free movement is very important and must be checked at the recommended intervals. If there is no free movement, the brake disks will wear quickly.

If there is too much free movement, accidents may occur. If there is not the same free movement between LH pedal and RH pedal, it may cause serious accidents.

Put the tractor on level ground, move the range lever in the L position.

Stop the engine.

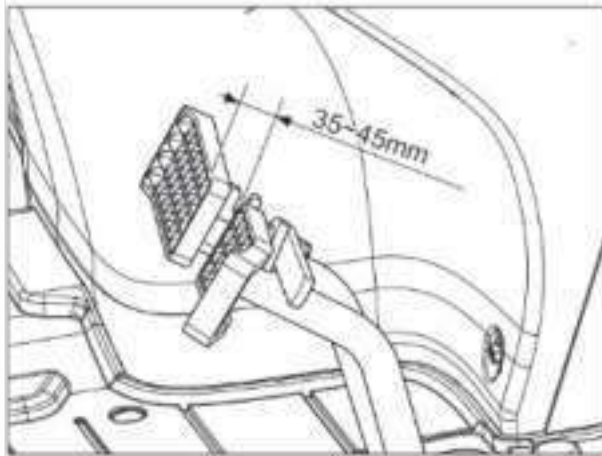

Loosen lock nut and rotate the brake rod to make a free play of 35 to 45 mm (1.38 to 1.77 inch.)

at the brake pedal.

With this free movement is obtained, tighten the lock nut.

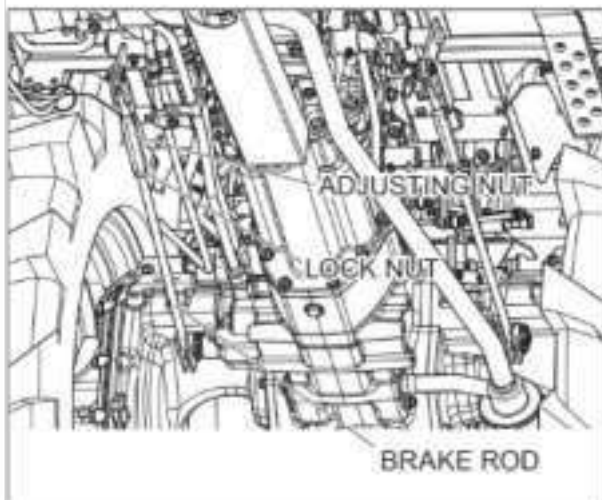

Confirm that the right and left brakes operate simultaneously by running the tractor.

If not, adjust both of them by means of the brake rods.

RAISE STOP SETTING POSITION

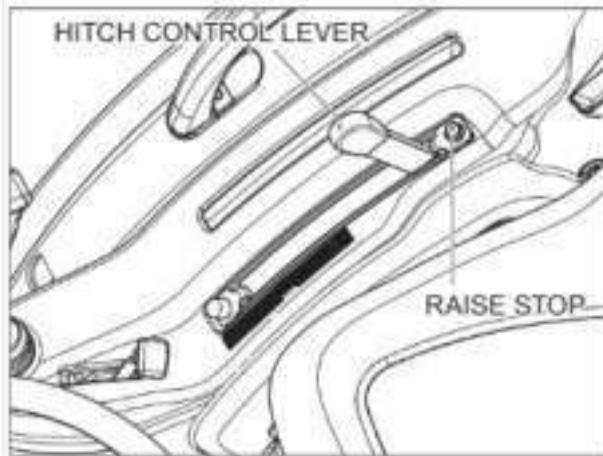

If raise stop setting position is incorrect, the hydraulic pump might be damaged. Therefore carefully adjust as below.

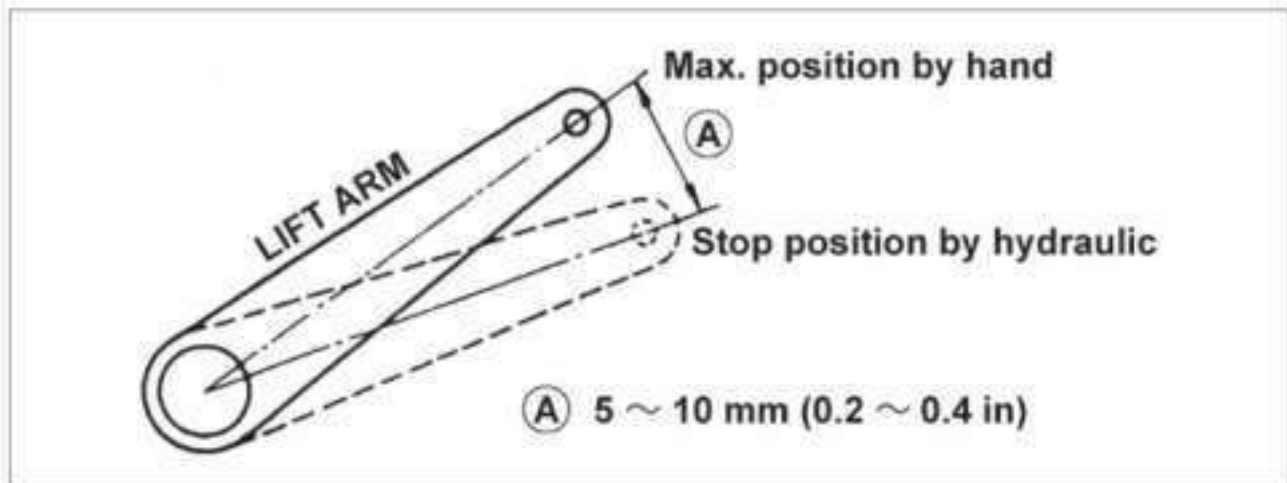

1. Disconnect an implement from the hitch. (See Disconnecting Implement from Hitch in this manual.)
2. Disconnect LH and RH lifts rods from the lift arms.
3. Start the engine.
4. Move the hitch control lever rearward to raise the lift arm to the maximum lifting position.
5. With the arm so raised, stop the engine.
6. Check a free play of the lift arm to be 5 to 10 mm at the top of the lift arm by hands.
7. If the free play is insufficient, move the raise stop forward and check again with the same procedure as before.

CHECKING ENGINE START SYSTEM



Do not allow anyone near the tractor while testing.
If the tractor does not pass the test do not operate the tractor.

[Gear Drive]

□ Preparations before the check.

1. Sit on the operator's seat.
2. Apply the parking brake.
3. Shift the all operating control lever to "N" or "OFF".

□ Check 1: Switch for the shuttle lever.

1. Depress the clutch pedal.
2. Shift the shuttle lever to "F" or "R".
3. Turn the key fully clockwise.
4. Make sure the engine must not crank.

□ Check 2: Switch for the Rear PTO lever.

1. Depress the clutch pedal.
2. Shift the Rear PTO lever to "ON".
3. Turn the key fully clockwise.
4. Make sure the engine must not crank.

□ If the tractor is equipped with Mid PTO, you check in accordance with same procedure as check 2.

□ Check 3: Switch for the operator's seat.

1. Depress the clutch pedal.
2. Leave the operator's seat. (Stand up)
3. Turn the key fully clockwise.
4. Make sure the engine must not crank.

[HST Drive]

□ Preparations before the check.

1. Sit on the operator's seat.
2. Apply the parking brake.
3. Shift the all operating control lever to "N" or "OFF".

□ Check 1: Switch for the clutch pedal.

1. Release the clutch pedal.
2. Turn the key fully clockwise.
3. The engine must not crank.

□ Check 2: Switch for the speed ratio control pedal.

1. Depress the clutch pedal.
2. Depress the speed ratio control pedal forward or reverse.
3. Turn the key fully clockwise.
4. The engine must not crank

□ Check 3: Switch for the Rear PTO lever.

1. Depress the clutch pedal.
2. Shift the Rear PTO lever to "ON".
3. Turn the key fully clockwise.
4. Make sure the engine must not crank.

□ If the tractor is equipped with Mid PTO, you check in accordance with same procedure as check 3.

□ Check 4: Switch for the operator's seat.

1. Depress the clutch pedal.
2. Leave the operator's seat. (Stand up)
3. Turn the key fully clockwise.
4. Make sure the engine must not crank.

ELECTRICAL SYSTEM

SPECIFICATIONS

Electrical System

Type of System.....12 Volt, Negative Ground
 Battery.....12 Volt, 925 CCA at 0°F (1050 CCA at 32°F)
 BCI Group Size 31, Top Stud Terminals
 Alternator.....12 Volt, 90 Ampere Output
 Voltage Regulator..... IC Built in Alternator
 Starter Motor 12 Volt, 2.2 kw with Solenoid Switch
 Head Lamp..... 55/60 Watt
 Flasher Lamp..... 23 Watt
 Rear Red Lamp..... 10 Watt
 Rear Working Lamp (If Equipped)..... 23 Watt
 Room Lamp (Cabin)..... 5 Watt
 Working Lamp Rear (Cabin)..... 27 Watt
 Working Lamp Front (Cabin)..... 55 Watt

FUSE DETAILS (MAIN)	
(a)10A	MAIN
(b)10A	HAZARD (TURN) LAMP, METER
(c)10A	ENGINE, STARTER RELAY, FUEL FILTER, METER
(d)15A	HEAD LAMP
(e)10A	TAIL LAMP, TURN SIGNAL
(f)10A	PTO VALVE, EXTRA POWER SUPPLY

FUSE DETAILS (ENGINE)	
(a)10A	ECU (K04) SUPPLY
(b)15A	FUEL METERING
(c)10A	ECU (K06) SUPPLY
(d)10A	DIAG CONN

FUSE DETAILS (CABIN)			
(a)-A	-	(g)10A	AUDIO (ACC)
(b)10A	HAZARD (TURN) LAMP, METER	(h)10A	ROOM LAMP, AUDIO (BACKUP)
(c)10A	ENGINE, STARTER RELAY, FUEL FILTER, METER	(i)15A	WORK LAMP (FRONT)
(d)15A	HEAD LAMP	(j)10A	WORK LAMP (REAR)
(e)10A	TAIL LAMP, TURN SIGNAL	(k)15A	AIR CONDITIONER
(f)10A	EXTRA POWER SUPPLY	(l)15A	WIPER MOTOR, WASHER PUMP

GENERAL SERVICE INFORMATION

Alternator Charging System

Follow these general rules to prevent damage to the electrical system:

1. Before working on the electrical system, disconnect the battery cables.
2. Do not make a reverse battery connection.
3. When you use an auxiliary for starting, connect positive-to-positive and negative on the auxiliary to the tractor side rail as a ground.
4. When charging the tractor battery, disconnect the battery cables from the battery terminals. Do not use a battery-charging machine for starting the tractor.
5. Never operate the tractor when the battery cables are disconnected.
6. When you do maintenance on the engine, prevent foreign material from entering alternator.
7. If you must do welding, disconnect the battery. Put the welder ground cable as close as you can to the weld area. Do not put the ground cable where the current can flow through bearings or along channels with wire harnesses.

ELECTRICAL SYSTEM

Fuses

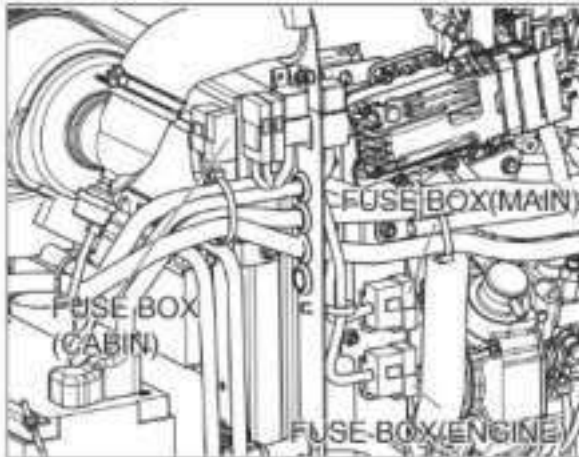

When opening the lid of the fuse box, push the lock part and the lid is opened.

Cartridge type fuses are used for headlamps, rear red lamp, instrument lamps, turn signal and flasher lamps, and rear work lamp (if equipped).

The fuses are in the fuse block located, L.H. front of engine room.

If a short circuit occurs, the fuse will burn out and break the circuit preventing damage to the electrical system.

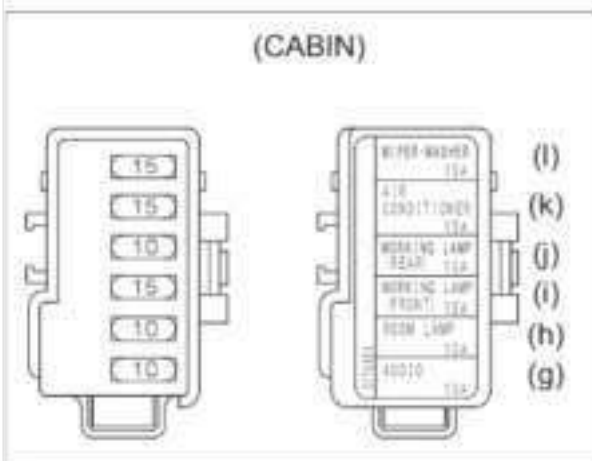
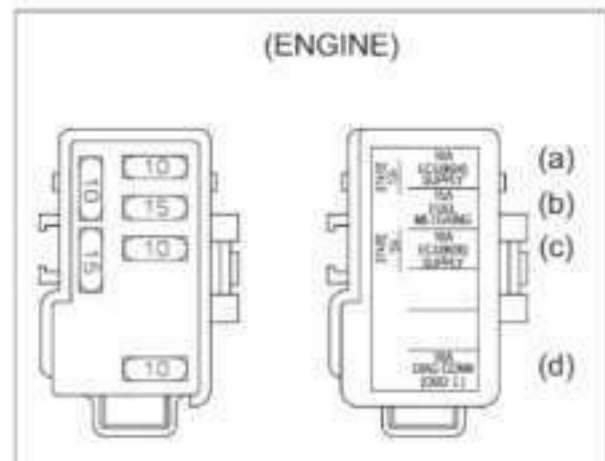
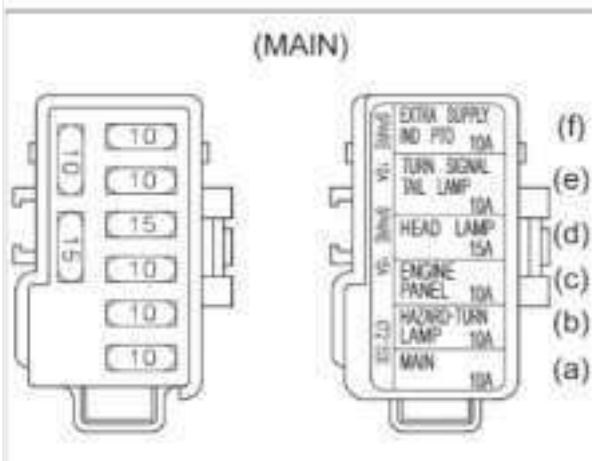

Line Fuse

If the electrical circuit is accidentally grounded or a reverse battery connection is made, the Line fuse located over the battery will burn out and break the circuit to prevent to damage the solenoid switch, wiring harness and alternator charging system . If electrical problems occur, the Line fuse must be checked for continuity to determine if one of the circuits is broken, see your Dealer to replace and correct.

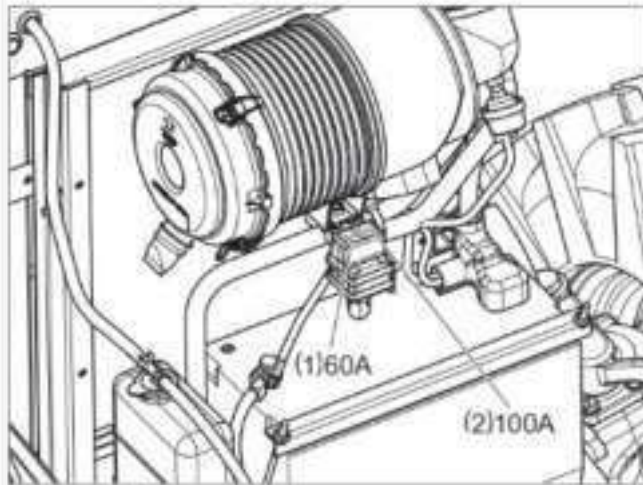

- (1) Protection of the main electrical machinery circuit.
- (2) Protection of the CHARGE circuit.

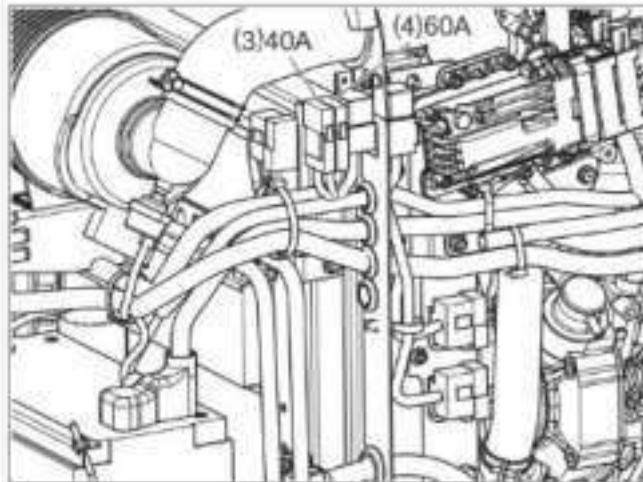
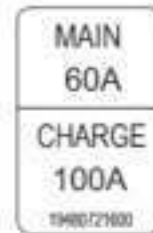

- (3) Protection of the Engine circuit.
- (4) Protection of the Engine electrical heat circuit.

NOTE: Exchange of the fuse is performed by opening the lid

BATTERY

Auxiliary Battery Connections



Engine can start with transmission in gear when neutral or safety start switch is by-passed:

1. Do not connect across terminals on starter.
2. Attach a booster battery by connecting the positive terminal of the booster battery to the "positive terminal" provided or to the positive terminal of the machine battery. Connect the negative terminal of the booster battery to the chassis of the machine.
Then use recommended starting procedures from operators seat.
3. When necessary repair electrical system components promptly so that "jump starting" will not be attempted.
Machine run-away can cause injury or death to operator and bystanders.

When connecting an auxiliary battery or charger to the tractor battery, make sure you connect positive-to-positive and negative on the auxiliary battery to the tractor side rail as a ground. Do not connect auxiliary battery cables across the terminals of the starter. Start the engine from the operator's seat.

IMPORTANT: This is the only safe method to start the tractor engine with an external power supply. Any other method of starting can cause injury or death to the operator or other persons.

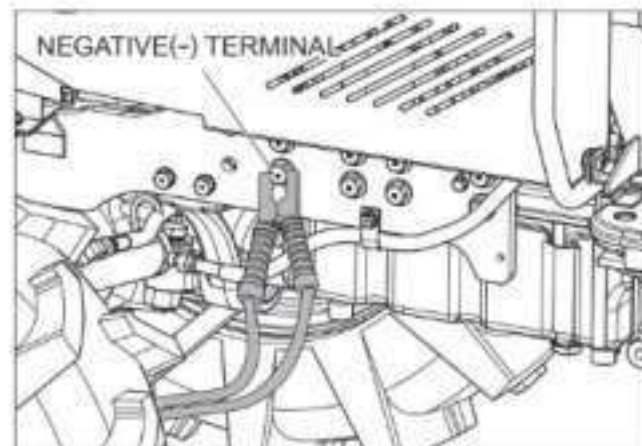
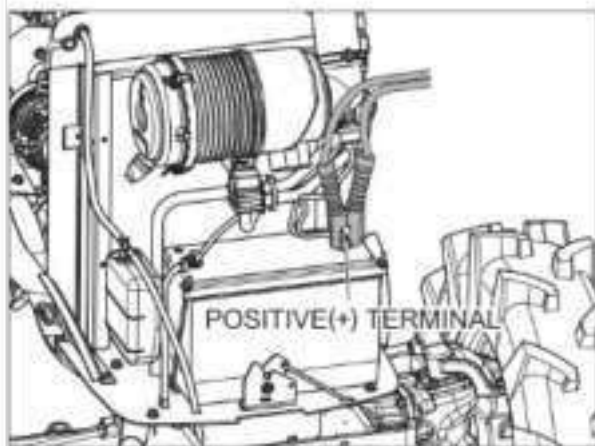

Connect the positive (+) cable clamp of the auxiliary battery to the positive cable terminal of the tractor battery.

Connect the negative (-) cable clamp of the auxiliary battery to the tractor side rail as a ground.

IMPORTANT: Always connect the negative cable last and disconnect the negative cable first to avoid a spark at the battery. A spark can cause a battery explosion and cause injury.

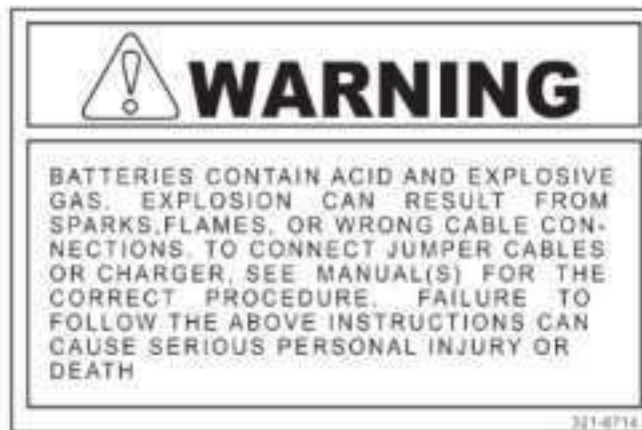

Battery Cables and Terminals

The battery Terminals must be kept clean and tight. A good method to clean terminals is to use Battery Saver. If Saver is not available, remove all corrosion with a wire brush, then wash with a weak solution of baking soda or ammonia. Put some petroleum jelly or light grease on terminals to prevent corrosion.

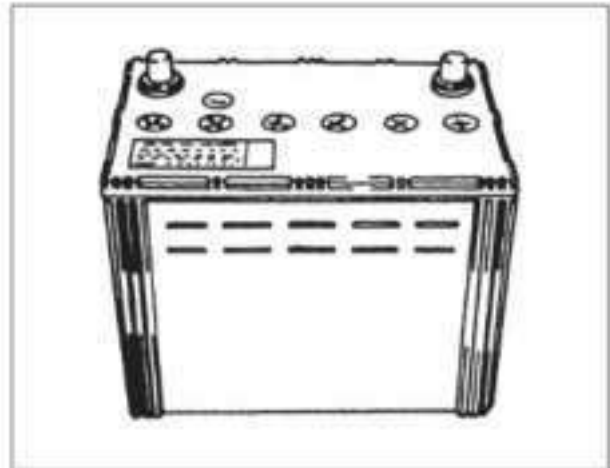

Removal and Installation of Battery

To remove the battery, disconnects the battery cables and remove the battery bracket. When the battery is installed, make sure the cables are installed on the correct terminals. This is a 12-volt, negative ground electrical system and must be so connected.

NOTE: When removing the battery, disconnect the negative cable from the battery first and when install the batter, reconnect negative cable last for safety reasons.

IMPORTANT: Do not start or operate the engine with the electrical system not completely connected.

ELECTRICAL SYSTEM

When Charging the Battery

IMPORTANT: Battery can explode during boosting or charging. Always wear proper eye protection, such as a safety goggles.

If the electric circuit inside the battery is broken, charging can generate a spark inside the battery, which can cause it to explode. If the battery is discharged, and the reason for discharge is unknown and if the lamps or horn do not indicate some battery voltage, check the battery with a volt meter for an open circuit using following procedure.

1. Disconnect the negative (-) cable.
2. Connect the voltmeter across battery terminals.
3. If there is no voltage present, an open internal circuit is indicated.
Replace the battery.
4. If voltage is present, the battery is OK to charge the battery with a current of 4 amperes for 5 to 10 hours. A current larger than specified will cause liquid overflow due to foaming.
5. The specific gravity of electrolyte of a fully charged battery is 1.280 at 20 °C (68 F).

NOTE:

1. If using a battery charger, be certain the charger is turned off before connecting to the battery.
2. Charge the battery in a well ventilated area.
3. Do not attempt to charge a frozen battery.



When working around storage batteries, remember that all of the exposed metal parts are "live". Never lay a metal object across the terminals because a spark or short circuit may result.

When Battery is Not in Use

When the tractor is not in use, the battery will need a charge every three months to keep the specific gravity at or above 1.240. A storage battery not in use will slowly discharge. A battery that has discharged can freeze at low ambient temperature and cause damage to the battery and tractor.

STORING THE TRACTOR

When your tractor is not to be used for some time, it should be stored in a dry and protected place. Leaving your tractor outdoors, exposed to the elements, will shorten its life. Follow the procedure outlined below when your tractor is placed in storage for periods up to approximately six months.

See your Dealer for the procedure on longer storage periods.

- A. Store the tractor so the tires are protected from light. Before storing the tractor, clean the tires thoroughly. Jack up the tractor, when it is to be out of service for a long period. If not jacked up, inflate the tires at regular intervals.
- B. Run the engine long enough to thoroughly warm the oil in the crankcase, and then drain the oil. Change the oil filter as instructed in Engine Oil Filter. Refill the crankcase with new oil as specified in Engine Oil Selection in this manual and run the engine for five minutes.
- C. Fill the fuel tank with a good grade of Number Two diesel engine fuel.
If this grade has not been used regularly, drain the fuel and refill. Run the engine for about five minutes to circulate the fuel through the injection system.
- D. Drain flush and fill the cooling system with an antifreeze mixture ratio to protect the engine to the lowest anticipated temperature or a minimum of 50 % antifreeze and add cooling system conditioner. See COOLING SYSTEM in this manual.
- E. Do not remove the battery from the tractor, except for prolonged storage at below freezing temperature. The battery should be fully charged to prevent freezing of electrolyte. Disconnect the negative ground cable at the battery to prevent possible discharge.
- F. Clutch assembly may become bound together if a tractor is not used for an extended period of time. A clutch lock latch is provided on your tractor to lock the clutch in the disengaged position and should be used to prevent this condition if your tractor is not used for an extended period of time.



CAUTION AT VEHICLE WASHING

If the pressure washer is operated incorrectly, it may cause an injury or damage, breakage, and failure of the tractor. Refer to the operator's manual and labels of the pressure washer for correct operation.



WARNING: For burn, fire, and injury prevention:

Diffuse the washing nozzle so as not to damage the tractor and wash it more than 2m away from it. If sprayed directly or washed inappropriately close to the tractor, the followings may occur.

1. It may cause a fire due to damage and disconnection of coating of electric wiring.
2. Highly compressed oil may be sprayed due to damage of the hydraulic hose, and it may damage the tractor.
3. It may cause damage, breakage, or failure of the tractor.

- e.g.)
- (1) Peeling of stickers and labels
 - (2) Failure by entry to electric components or engine and radiator cabin
 - (3) Damages of rubber parts such as fire and oil seal, plastic parts such as decorative cover, and glasses.
 - (4) Peeling of paint and coating

DIRECT CAR WASHING STRICTLY PROHIBITED

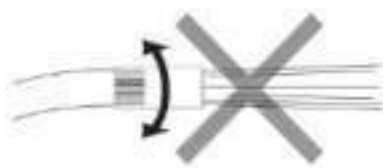

DIRECT SPRAY

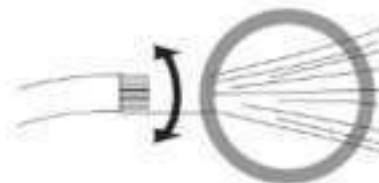

DIFFUSIVE SPRAY

CLOSE CAR WASHING STRICTLY PROHIBITED

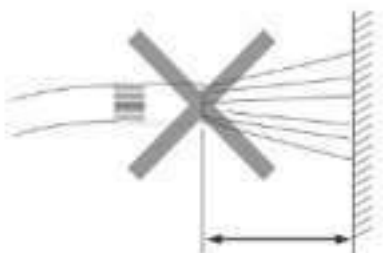

LESS THAN 2M

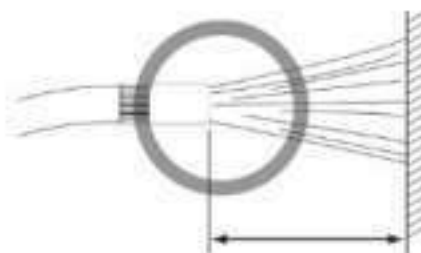

MORE THAN 2M

IMPORTANT: When washing the tractor with pressure washer, DO NOT directly spray the water to the meter panel, steering column, battery and electric components. Cause damage to the electric components. DO NOT spray the water to the electric wiring part around the engine. It may cause an engine start failure.

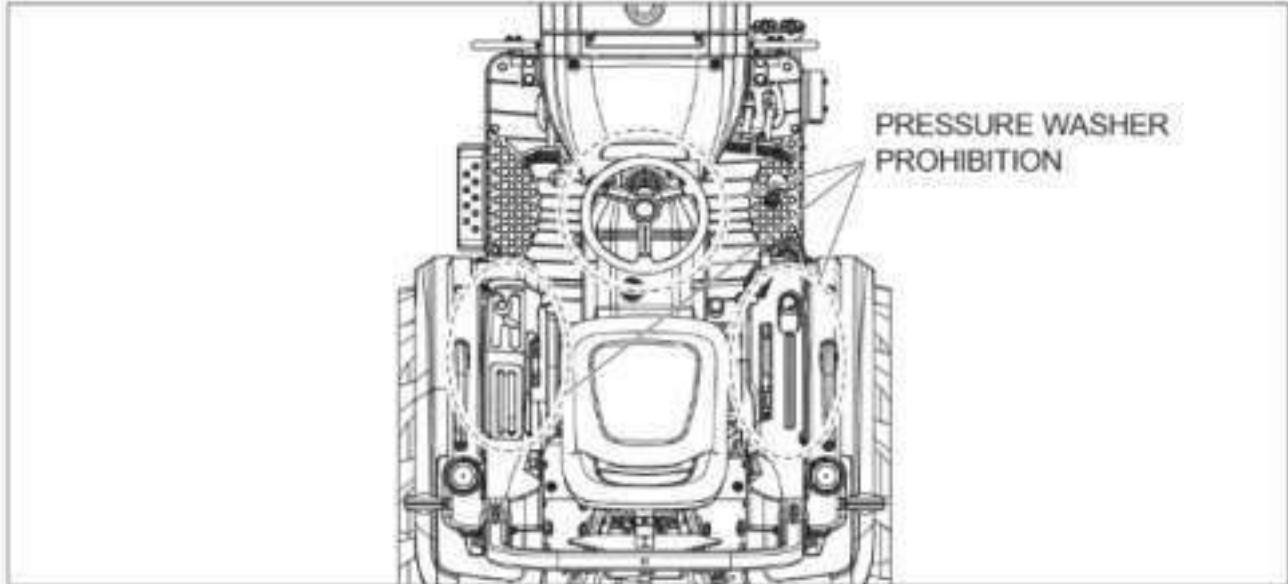

IMPORTANT: When washing the tractor with pressure washer, DO NOT directly spray the water to glass and roof (reduce water pressure).

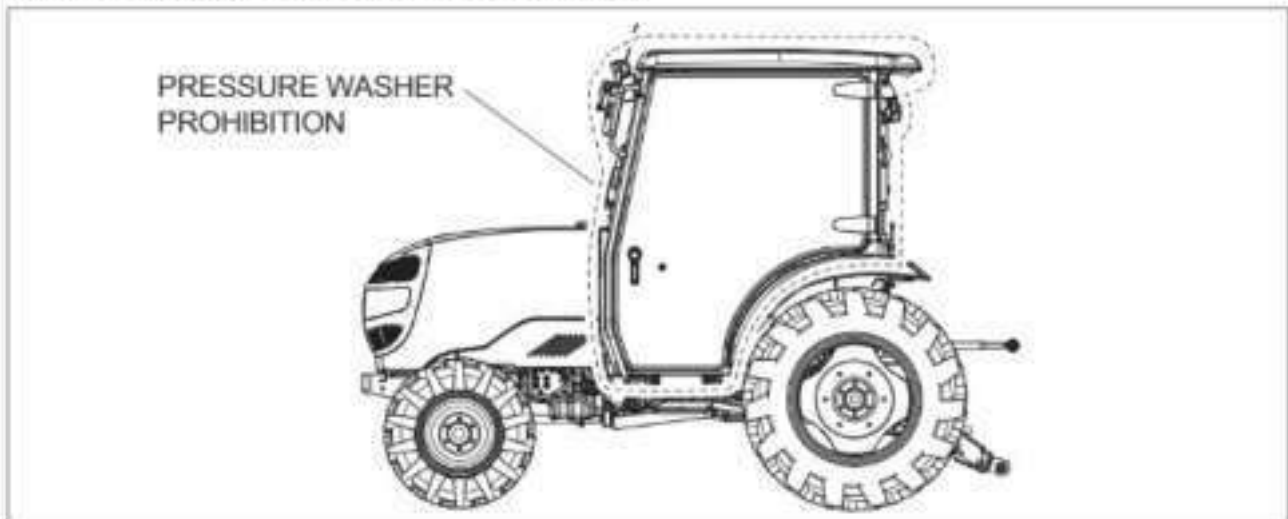

REMOVING FROM STORAGE

Be sure that the grade of oil in the engine crankcase is as specified in Engine Oil Selection in this manual.

- A. Loosen the fuel tank drain plug and fuel filter cup, and be sure all water and sediment has drained from the fuel system before closing.
Tighten the drain plug and replace the filter cup.
- B. Check the level of the coolant in the radiator.
- C. Check engine oil level.
- D. Check hydraulic fluid level.
- E. See that the battery is fully charged and that the terminal connections are clamped tightly.
- F. On hydrostatic drive tractors, follow the same procedure for starting as Starting Procedure for Hydrostatic Drive Tractors after Transporting on truck or flatcar in this manual.
- G. Start the engine and let it run slowly.

IMPORTANT: Keep the doors wide open and move the machine outside of the storage room immediately to avoid danger from exhaust fumes. Do not accelerate the engine rapidly or operate it at high speed immediately after starting.

CABIN

INSTRUMENT AND RELATED PARTS

DOORS



WARNING: When you drive your cabin with half-shut, door opens suddenly, and it could cause any accidents. Check doors if its fully closed before driving.



1. Doors Lock/Unlock

When you put a key and turn it to the left, you can lock the door.

If turn it to the right, you can unlock.



2. How to Open from Outside of Cabin

When you pull door handle while holding down push button, you can open the door.



3. How to Open from Inside of Cabin

When you push door lever, you can open the door.

Also when you pull a door frame, you can close the door.

CABIN

REAR WINDOW



WARNING: Opening windows suddenly may cause personal injury. Whenever opening the rear window check the surrounding area to make sure it is safe before opening. Opening windows suddenly can cause personal injury. Be very careful when opening and closing rear window to remove/reinstall and adjust working equipment. (As there is a danger that the person in the cab could hit his head or other body parts when the window is open)



The rear window is a pop-up type window.

1. How to open:

- | Rotate the lever clockwise.
- | Push the lever outward and open the rear window.

2. How to close:

- | Pull the lever toward you and close the rear window.
- | Then rotate the lever to the counterclockwise while pulling it toward you and lock it securely in place.



NOTE:

1. There are cases where the rear window cannot be opened depending on the working equipment used so check for this before performing operations.
2. When removing/reinstalling and adjusting or working on working equipment at the rear side of the tractor, either close the rear window or check the open position before performing such operations.
3. Do not drive the tractor on the road with the rear window left open. The glass can be damaged by vibration. Close the rear window and lock the lever securely in place.
4. If the door and/or rear window is frozen due to cold weather, forcing it open can cause the rubber to peel off or become damaged. Use warm water to defrost before opening.
5. Do not place your whole body weight onto the doors and do not forcefully push the doors beyond its normal operating range.

STARTER KEY SWITCH

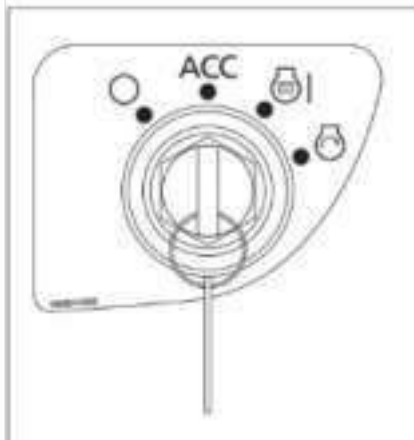

The starter key switch can be removed in the OFF position. Four switch positions are as follows:



position (OFF)

Engine and all lamps except the turn signal and flasher lamps are turned off.



Position (ACCESSORY)

The audio (option) can be operated in this position.



Position (HEAT)&(ON)

First position clockwise from OFF. In this position (Engine not running) electrically heats the engine (if needed). The charge indicator oil pressure indicator, engine system failure or malfunction indicator, engine emission system failure or malfunction indicator and instruments panel lighting will illuminate.

The fuel gauge and temperature gauge will show correct values.



Position (START)

Turn the key fully clockwise against the force of the spring in the switch. The starter motor will turn the engine. Release the key immediately when the engine starts.

NOTE: To prevent operation by persons not authorized and the possible discharge of the battery, remove the starter key when you leave the tractor.

IMPORTANT: Do not keep the starter key switch in the ON position for a long time when the tractor is not operating.

CABIN

WORKING LAMPS



When you turn key to "  ON" and push upper side of working lamp switch, working lamp, and lamp on the switch lights up.
If you push downside of the working lamp switch, you can turn off the lights.

NOTE:

1. When you use working lamp, turn on the switch after starting engine to avoid battery runs out.
2. When you drive on the road, Turn off working lamp.

ROOM LAMP



Room lamp is used for lighting up in your cabin.

┆ "ON".....Room lamp is turned on.

┆ "OFF".....Room lamp is turned off.

WIPER WASHER CONTROL SWITCH (FRONT AND REAR)



(1) Wiper operation

Push (A) side of switch to activate wipers and push (B) side of switch to stop wipers.

Washer operation

While wipers are running.....Push (A) side of the switch and washer fluid will spray as long as you hold the switch down.

While the wipers are stopped.....Push (B) side of switch and washer fluid will spray as long as you hold the switch down.

NOTE:

- The wiper washer system will not activate when the key is set to "OFF".
Operate the system after either setting the key to "ON" or starting engine.
- If the wipers are used when the glass is dirty with dust and/or dirt, the glass can get scratched.
Clean the tractor or spray washer fluid before using system.
- If you try to use the wipers in cold weather where the wiper blades freeze and sticks to the glass, the wipers cannot operate so a built-in circuit breaker will activate. If the circuit breaker activates, defrost the wiper blades and wait for some time before using the wipers. Inspect the condition of the wiper blades before running wipers.
- If the wiper blades stop while running due to heavy snow build-up, electric power will continue to be supplied even if the wiper switches are switched "OFF" so the fuse may blow out unless the key is set to "OFF". Take the tractor to a safe location, set the key to "OFF" and clean off the built-up snow, etc. so that the wiper blades can operate again.
- If you spray washer fluid for more than 60 seconds continuously or try to use the washer fluid for more than 20 seconds when no washer fluid is coming out, the wiper motor could overheat.
- When using the washer in very cold weather, the washer fluid sprayed onto the glass could freeze and obscure visibility so warm up the window glass using the heater first before use.
- Use commercially available washer fluid. If tap water is used in cold weather, the water could freeze causing damage to the washer tank, hose or other parts of the system.

CABIN

REAR MIRROR

Rear mirror can be adjusted to easily viewable position on the seat.

If you store your cabin in a narrow space, the mirrors can be folded to forward to avoid interference with external obstacles.



NOTE:

1. When usually operating, rear mirror stick out of the cabin. Be careful not to touch when pass each other at a narrow space and store your cabin.
2. Don't turn rear mirror to backward from [Operating condition] .It can be damaged by bumping into antenna.

CUP HOLDER



A drink cup can be held on with using cup holder.

AIR CONDITIONER

**WARNING:** To prevent personal injury

If the air conditioning system breaks, turn the switch OFF and take it in to have it checked. The air conditioning system is filled with high pressured gas so if any piping and/or parts of the compressor become loose it is dangerous as the gas could blow out. Refilling coolant (gas) and other operations require special tools and instruments so always have this type of work performed at an authorized service shop with properly maintained facilities.

Do not come into direct contact with any water hoses and/or the heater unit as this may lead to personal injury such as burns.

If you fail to have repairs performed when the following abnormalities are recognized, this can lead to personal injury accidents such as burns and/or serious failures such as overheating the engine.

Water hose is damaged, cracked and/or has swelling.

Leakage from water hose joint area.

Water hose protecting tube and grommet separation and/or damage.

Bolts of main unit are loose and brackets are damaged.

1. Control Panel



(1) Air conditioning switch



Push this switch to turn the air conditioning "ON" and "OFF".

The lamp in the center of the switch will light up when the air conditioning is "ON".

(2) Mode lever



Air will blow from all ports of the front ventilator and side ventilator when the lever is in this position



Air will blow through the front ventilator ports when the lever is in this position.

(3) Temperature control lever

This lever is used to adjust the temperature. Set to desired position to adjust to appropriate temperature. Slide to the right for heat and slide to the left for cool air.



CABIN

- (4) Fan switch
Adjusts fan speed.



"OFF"	: Fan does not operate.
"LO"	: Low speed.
"ME"	: Medium speed
"HI"	: High speed.

2. Heater

- (1) The mode lever can be set to either.  or .
- (2) Adjust the fan switch (LO/ME/HI) and temperature control lever to set a comfortable temperature.

3. Cooling & Dehumidifying Heat

- (1) Set mode lever to .
- (2) Push the air conditioning switch and set to "ON".
- (3) Operate fans by setting fan switch to LO, ME or HI.
- (4) Adjust the control lever to COOL or an intermediate position to set a comfortable temperature.

4. Cool Head-Warm Feet

Use the temperature control lever in an intermediate position when in the "Cooling & Dehumidifying Heat" driving state for cool air around the head and warm air around the feet (cool head-warm feet) to provide a comfortable driving state.

5. Defroster

To defog or defrost front glass:

Open the front ventilation ports and direct it to blow in the direction of the front glass.

 Set the mode lever to .

Set fan switch to HI and slide temperature control lever to WARM (right side).

NOTE:

1. Use anti-freeze concentration suited to outside ambient temperature during winter. Additionally, do not use anti-freeze that has expired.
2. If you do not want to use anti-freeze in winter, you should drain the coolant from the main tractor unit after completing tractor operation.
3. Use anti-freeze concentration suited to outside ambient temperature during winter. Additionally, do not use anti-freeze that has expired.
4. If you do not want to use anti-freeze in winter, you should drain the coolant from the main tractor unit after completing tractor operation.
(See the tractor operation manual for procedures to drain the coolant out of the system).

5. Have the water hoses replaced every 2 seasons.
6. There are times when it may seem as though mist is blowing out of the ventilation ports momentarily when starting to cool. This mist is caused by the sudden cooling of moisture in the air and not a malfunction of the system.
7. When the engine coolant temperature is low, no heat will blow from the ports even if you set it to "WARM".
8. When operating the system for an extended period of time or when smoking make sure to ventilate the cab periodically.
9. Visibility will be hindered if the window glass fogs up so wipe away the excess moisture using a soft piece of cloth.
10. During the summer when the heater is not in use, slide the temperature control lever to COOL (all the way to the left) to keep the temperature inside the cab from rising due to hot air.
11. The air conditioning does not only cool down the temperature, it can also lower the humidity levels at the same time. However, overcooling is not good for your health so adjust to a temperature that feels slightly cool (about 5 to 6 degrees cooler than outside ambient temperature). It is also advised to avoid using the air conditioning with cold air blown directly onto your body for an extended period of time.
12. Set the air conditioning switch and the fan speed controlling switch to the "OFF" position before putting the tractor away for storage.
13. Operate the air conditioning for 10 to 15 minutes, once a month even during the off season. Operate the engine at a low speed, set the temperature control lever to the "COOL" position, set the fan speed controlling switch to the "LO" position and turn the air conditioning switch to "ON". Operating the air conditioning system periodically will prevent refrigerant gas leakage and make it possible to maintain the best condition for the air conditioning system.

6. Front Ventilator



(1) The direction for the air to blow can be adjusted flexibly by the ventilation ports.

To use the ports as a defroster (defogging front glass), point the ventilation ports to blow on the front glass.

(2) To increase the amount of air blown out of the side ventilators, set to "CLOSED".

CABIN

7. Side Ventilator



- (1) Turn side ventilator in any direction with adjust knob.

LUBRICATION



1. REAR WINDOW HINGE

- | Lubricate appropriate gear oil to the hinge area. (2 points)
- | When rear window does not open and close easily, or when rear window makes sounds, lubricate to rear window hinge.

2. DOOR HINGE

- | Lubricate appropriate gear oil to the door hinge area. (One side 2 points)
- | When door does not open and close easily, or when door makes sounds to open and close, lubricate to door hinge.

REFILL WASHER FLUID

Washer Tank



- | Open tank cap, and refill washer fluid.
- | Capacity.....1.5 L.

HOW TO CLEAN EACH PARTS

1. Clean Capacitor Fin, Capacitor Screen



WARNING: To prevent fires
When cleaning capacitor fin and capacitor screen, start after engine stopped and cool down.

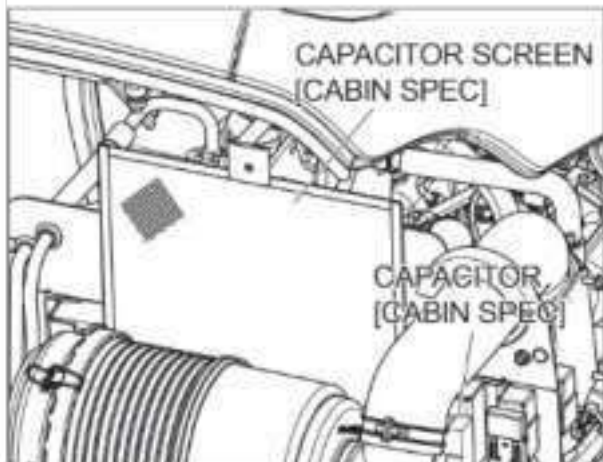

1. Open bonnet.
2. Pick capacitor screen to upward.
3. Remove dust on capacitor screen.
4. Check if capacitor fin clogged. When clogged, remove straws on capacitor fin, and spray air from engine fan side to remove dust.

NOTE: Clean capacitor positioned in front of radiator at the same time.

CABIN

2. Cleaning The Air Conditioning



WARNING: To prevent personal injury

Steam cleaning the compressor and receiver will cause the refrigerant gas pressure to rise enough to trigger a rupture that will cause personal injury so avoid steam cleaning.

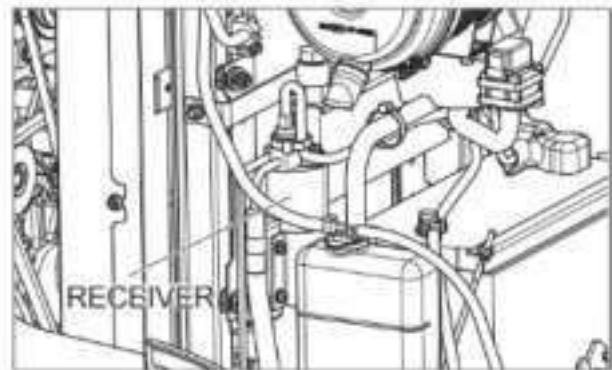
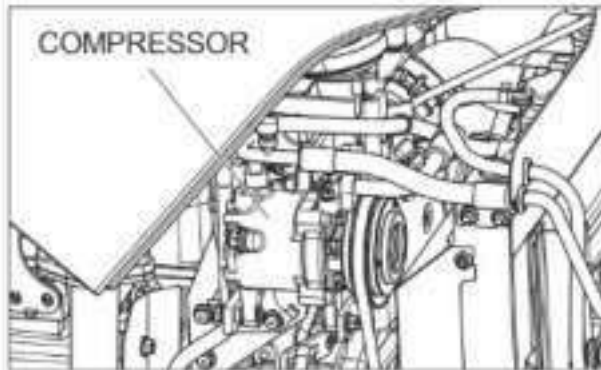

Cleaning the air intake filter

The amount of air blown from the ventilation ports is reduced as the filter clogs up with dust so clean with water or blow compressed air through the filter to remove all dust without damaging the filter.

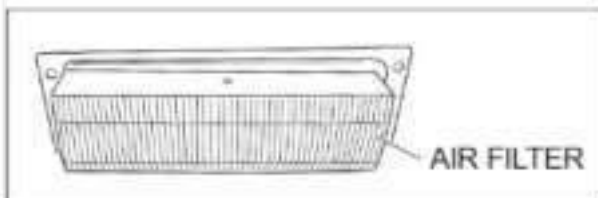
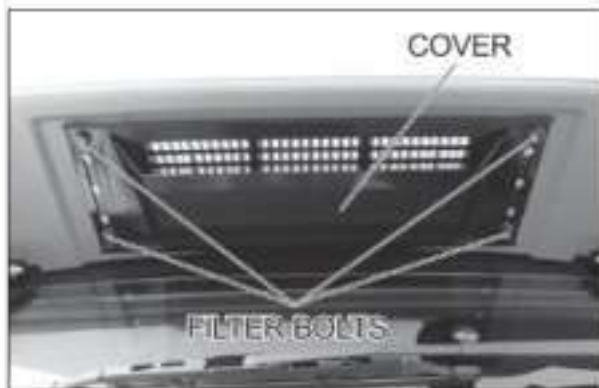

Cleaning of air filter

(1) Unfasten filter bolts (4 bolts) positioned backward of the cabin, and remove the cover.

(2) Air filter can be removed, and clean it with air compression. Don't hit air filter.

NOTE: If air filter become deformed, air conditioner will get some dusts and it may cause some damage.

NOTE:

1. If the amount of dirt/dust is excessive, wash with a mild household detergent and warm water solution, soak and shake to clean and rinse well with clean water.
2. Then wait for the filter to dry naturally before reinstalling it back onto the tractor.
Do not use gasoline, paint thinner, etc. for cleaning.

3. Water Hose Air Conditioning Piping Inspection



WARNING: In order to prevent burns, fires & personal injury
Make sure to check if any of the water hose joints are loose. If the water hose comes off while in operation, scalding hot water will squirt out.

Inspection

(1) Inspect to see if there is: any gas leakage due to aging or damage on water hose or air conditioning piping; any water or oil leakage; or looseness at tightening bands.

Treatment

If any gas leaks, water leaks, oil leaks and/or loose bands are found take it in to "the dealer where you bought your tractor" for inspection.

4. Compressor Belt Tension Adjustment

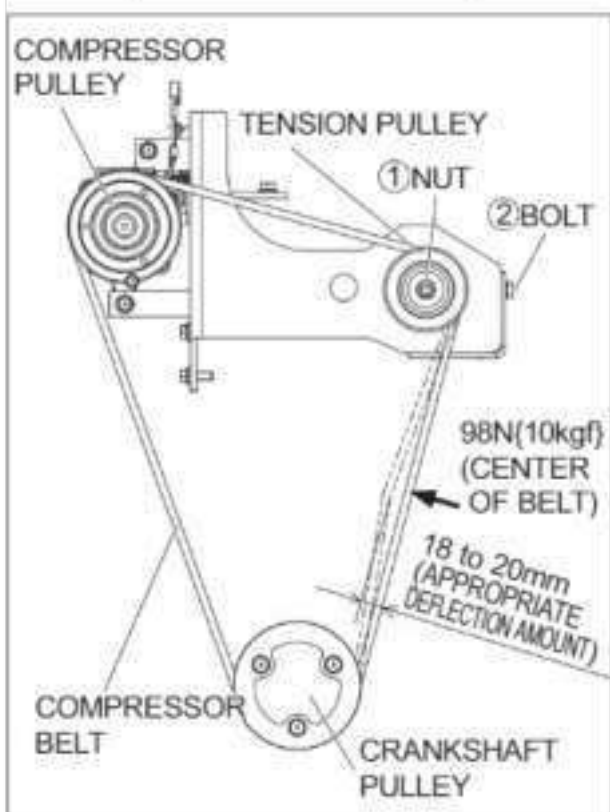

Inspection.....

(1) If the compressor belt deflection is within a range of 18-20mm when you push the center (with a pushing force of about 98N) as shown in the figure, it is okay.

Adjustment.....

(1) Perform compressor belt tension adjustment after the hour meter has passed 100 hours.

- 1) Loosen the tension pulley nut (1).
- 2) Turn bolt (2) for the tension pulley to the right to adjust.

3) Tighten tension pulley nut (1).

Tightening torque: 44 to 54N·m (4.5 to 5.5kgf·m)

4) Steam cleaning the compressor and the receiver is dangerous as it raises the pressure of the refrigerant gas so avoid steam cleaning.

NOTE: Replace the belt if damage is found on the belt and the deflection does not reach 18-20mm

CABIN

5. Refrigerant (Gas)

The air conditioning performance will be diminished if there is a shortage of coolant. Inspect according to the following procedures and if there is a lack of refrigerant, take the tractor in to "the dealer where you bought your tractor" for inspection and have it refilled.



Inspection

(1) Drive the air conditioning under the following conditions:

- | Engine speed : 1500rpm
- | Temperature control lever : Top cooling position
(all the way to the left)
- | Fan switch : Top setting (HI)
- | Air conditioning switch : ON

(2) Check to see the flow condition of the refrigerant through the sight glass.

Refrigerant Gas
It is advised to start the air conditioning system for 15-20 minutes once a month to avoid damage / leakage of the refrigerant.



Appropriate level

Condition where almost no bubbles can be seen flowing through when you look through the sight glass is a normal condition.



Insufficient

If bubbles pass through continuously (many bubbles) when you look through the sight glass then there is a lack of refrigerant.

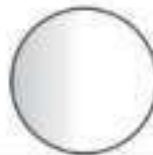

Empty

If cooler gas cannot be seen (no bubbles at all) when you look through the sight glass then this condition means that you are out of refrigerant.

POWER TAKEOFF (MID PTO):Gear Drive

Mid PTO

The Mid PTO has a 25.4 mm(1 inch) diameter 15 spline output shaft.

ENGAGE THE MID PTO AS FOLLOWS:

1. Confirming disengage the clutch, pushing the PTO switch.
2. Move the Mid PTO control lever to the ON position.
3. Turn right PTO switch to engage the PTO clutch. (turning the PTO shaft)

DISENGAGE THE MID PTO AS FOLLOWS:

1. Push the PTO switch to disengage the PTO clutch. (stop the turning of PTO shaft)
2. Move the Mid PTO control lever to the OFF (Engine Start) position.

NOTE: Keep the Mid PTO control lever in the OFF (Engine Start) when starting the engine and when the PTO is not being used.

The following table shows the required engine speed to get the required Mid PTO output shaft speed.

Push the PTO switch in the emergency. The rotation of PTO stops.

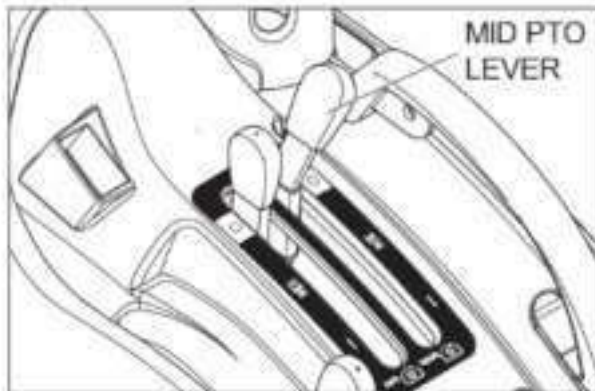
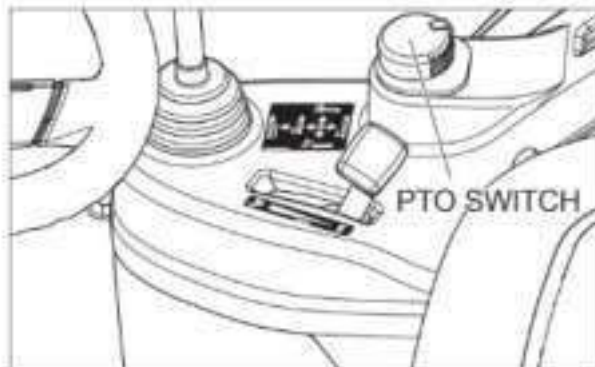
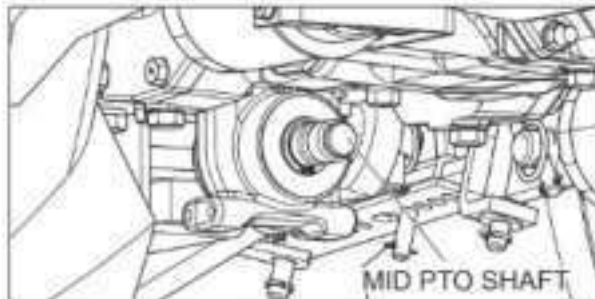

Mid PTO Output Shaft Speed	Required Engine Speed
2000 RPM	2526 RPM

OPTIONAL EQUIPMENT

POWER TAKEOFF (MID PTO) : Hydrostatic Drive

Mid PTO

The Mid PTO has a 25.4 mm(1 inch) diameter 15 spline output shaft.

ENGAGE THE MID PTO AS FOLLOWS:

1. Push the clutch pedal fully.
2. Move the Mid PTO control lever to the ON position.
3. Release the clutch pedal slowly.

DISENGAGE THE MID PTO AS FOLLOWS:

1. Push the clutch pedal fully.
2. Move the Mid PTO control lever to the OFF (Engine Start) position.
3. Release the clutch pedal.

NOTE: Keep the Mid PTO control lever in the OFF (Engine Start) when starting the engine and when the PTO is not being used.

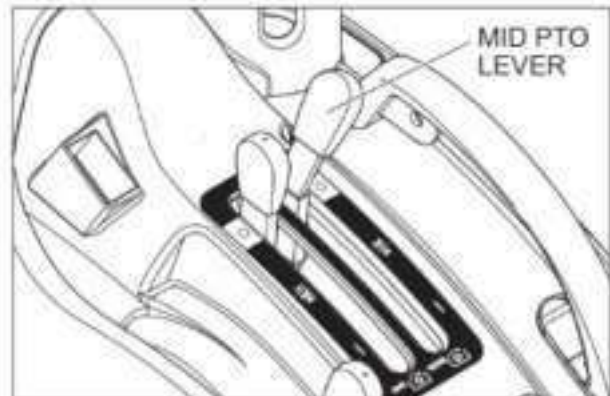
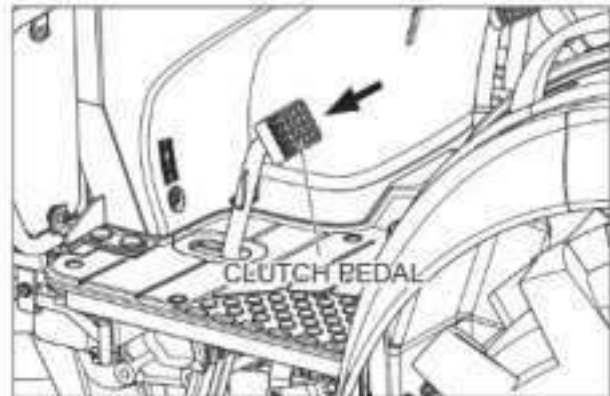
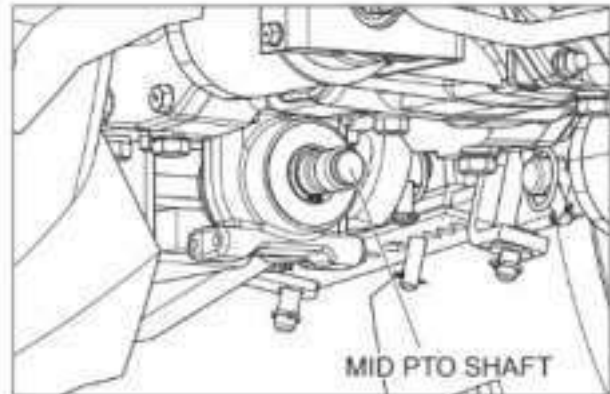

The following table shows the required engine speed to get the required Mid PTO output shaft speed.

Mid PTO Output Shaft Speed	Required Engine Speed
2000 RPM	2526 RPM

REMOTE HYDRAULIC CONTROL VALVE

A double acting remote hydraulic control valve with a "float position", is available from your Dealer.

If equipped, the control lever is located on the right side.

Connect the implement hoses to the remote hydraulic couplers so that the implement lowers when the control lever is pushed forward and raises when the lever is pulled rearward.

Switch the hoses if the implement works in the opposite way.

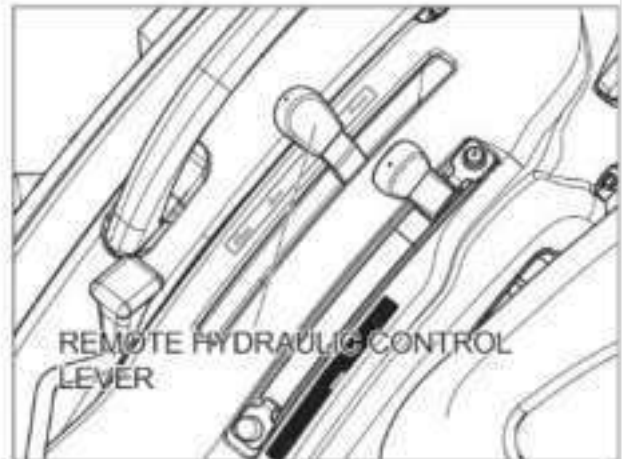
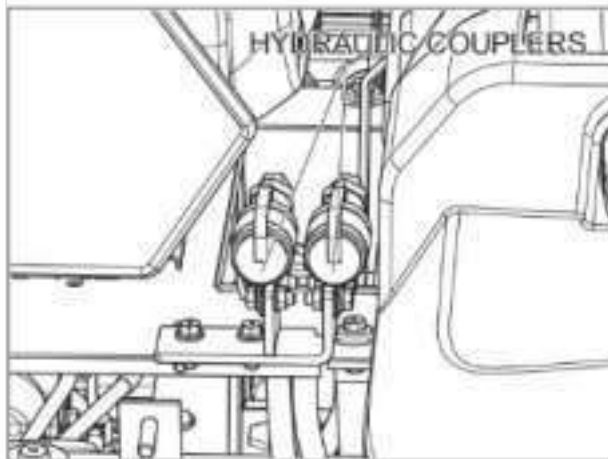

OPTIONAL EQUIPMENT

REMOTE HYDRAULICS OPERATION

Float Operation

To operate the remote hydraulics in a float condition, move the control lever fully forward to the detent position.

The lever will not return to neutral automatically when in the float position.

IMPORTANT: If implement is attached that has single acting cylinders, always use the "FLOAT" position when lowering. Continual use of the "LOWER" position will cause overheating and possible damage to the hydraulic system.

NOTE: The control lever for the remote hydraulic valve must be in the neutral for the three point hitch to operate.

IMPORTANT: Never park a tractor with an implement in the raised position. Moving the control lever forward will lower the implement even though the engine is not running. If it is necessary to service the implement in the raised position, use jack stands to safely block the implement in place. Put the hydraulic flow control knob in the LOCK position.

