

**Mahindra**  
Rise.



# Mahindra

TRACTORS

OPERATOR'S MANUAL  
**2670** PST CAB





# Mahindra

## TRACTORS

OPERATOR'S MANUAL  
**2670** PST CAB











## FOREWARD

Thank you very much for purchasing our tractor, which, we feel sure will yield, trouble free service  
The introduction in this manual explains the correct manner of operating, maintaining and checking the tractor to ensure long-term durability.

Please ensure the correct operation of the tractor as incorrect operation can cause substantial mechanical damage as well as accidents and associated injuries.





Please note that in some cases differences can exist between this manual and your tractor due to the manufacture's policy of constant product improvement.

In the event that you encounter a problem not covered by this manual please contact your nearest dealer who will assist you in resolving it.

 <b>WARNING</b>	<p style="text-align: center;"><b>CALIFORNIA Proposition 65 Warning</b></p> <p>Breathing diesel engine exhaust exposes you to chemicals known to the State of California to cause cancer and birth defects or other reproductive harm.</p> <ul style="list-style-type: none"> <li>-Always start and operate the engine in a well-ventilated area.</li> <li>-If in an enclosed area, vent the exhaust to the outside.</li> <li>-Do not modify or tamper with the exhaust system.</li> <li>-Do not idle the engine except as necessary.</li> </ul> <p>For more information go to  <a href="http://www.P65warnings.ca.gov/diesel">www.P65warnings.ca.gov/diesel</a></p>
 <b>WARNING</b>	<p>Cancer and Reproductive Harm  <a href="http://www.P65Warnings.ca.gov">www.P65Warnings.ca.gov</a></p>

### WARNING SIGNS IN THIS MANUAL

The following warning signs in this manual draw additional attention to items of importance for the safe and correct operation of the tractor.

SIGN	MEANING OF THE SIGN
 Danger	Serious hazard with a very high risk level of either serious injury or death.
 Warning	Hazard or unsafe practice that can lead to severe injury or death.
 Caution	Hazard or unsafe practice that can lead to injury or death.
 Important	Instructions for the correct operation of the machine which, if followed, will ensure that it performs at it's best.

All information, illustrations and specifications in this manual are based on the latest information available at the time of publication. The right is reserved to make changes at any time without notice.

## CONTENTS

Sr. No.	Description	Page No.
1.	Tractor Identification .....	3
2.	About this manual .....	4
3.	Introduction & Description .....	5~7
4.	Owner assistance .....	8~9
5.	Safety instructions, Do's & Don'ts .....	10~22
6.	Safety signs .....	23~25
7.	Universal symbols .....	26
Section A		
8.	Controls, Instruments & Operations .....	27~52
Section B		
9.	Lubrication & maintenance .....	53~75
Section C		
10.	CABIN .....	76~87
Section D		
11.	Specifications .....	88~92
12.	Fuel Saving Tips .....	93~94
13.	Fault Tracing .....	95~98
14.	Wiring Diagram .....	99
15.	Tractor History Card .....	100
16.	Service Record .....	101
17.	Daily Operating Log .....	102
18.	Part Replacement Record .....	103

---

All information, illustrations and specifications in this manual are based on the latest information available at the time of publication. The right is reserved to make changes at any time without notice.

## TRACTOR IDENTIFICATION

The engine number is stamped on the right hand side of the engine block.

The chassis number is shown on the left hand side of the tractor as shown in the drawing.

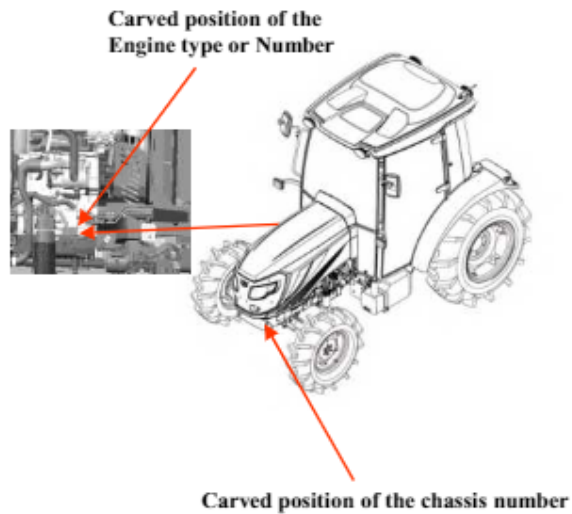

### **WARRANTY OF THE PRODUCT.**

The manufacturer warrants this product and full details of the warranty are provided on a separate warranty schedule.

### **SERVICE.**

Service is available from any Mahindra dealer in the country.

### **PARTS.**

To obtain spare parts please contact your nearest dealer and give him/her these details

Tractor model

Tractor serial number

Tractor engine number

Part number and description

Quantity required.

## ABOUT THIS MANUAL

This manual has been prepared to assist you in following/adopting the correct procedure for running-in operation and maintenance of your new Mahindra Tractor.

Your Tractor has been designed and built to give maximum performance, with good fuel economy and ease of operation under a wide variety of operating conditions.

Prior to delivery, The tractor was carefully inspected, both at the factory and by your Mahindra Dealer/Distributor, to ensure that it reaches you in optimum condition.

To maintain this condition and ensure trouble free performance.

It is important that the routine services, as specified in this manual, are carried out at the recommended intervals.

Read this Manual carefully and keep it in a convenient place for future reference.

If at any time you require advice concerning your Tractor, do not hesitate to contact your Authorized Mahindra. dealer/Distributor.

He has trained personnel, genuine parts and necessary equipment to undertake all your service requirements.

The Manufacturer's policy is one of continuous improvement, and the right to change prices, specifications or equipments at any time without notice is reserved.

All data given in this book is subject to production variations.

Dimensions & weight are approximate only and the illustrations do not necessarily show Tractors in standard condition.

For exact information about any particular Tractor, please consult your Mahindra dealer/Distributor.

## INTRODUCTION & DESCRIPTION

### TRACTOR AN INTRODUCTION

The word, “Tractor” has been derived from “Traction” which means pulling.

A Tractor is required to pull or haul an equipment, implement or trolley which are coupled to the Tractor body through suitable linkage.

A Tractor can also be used as a prime mover as it has a power outlet source which is called the Power Take or PTO shaft.

In this book the operating, maintenance and storage instructions for all models of Mahindra Diesel Tractors have been complied.

This material has been prepared in detail to help you to better understand the maintenance and efficient operation of the machine.

If you need any information not given in this manual, or require the services of a trained mechanic, please get in touch with the Mahindra Dealer/Distributor in your locality.

Dealer/Distributors are kept informed of the latest methods of servicing Tractors.

They stock genuine spare parts and are backed by the Company’s full support.

Throughout this manual, the use of the terms LEFT, RIGHT, FRONT and REAR must be understood, to avoid any confusion when following the introductions.

The LEFT and RIGHT means left and right sides of the Tractor when facing forward in the driver’s seat.

Reference to the FRONT indicates the radiator end of the Tractor, while the REAR, indicates the drawbar end. (illustration B)

When spare parts are required, always specify the Tractor and engine serial number when ordering these parts.(See illustration A).

This will facilitate faster delivery and help ensure that the correct parts for your particular Tractor is received.

The tractor serial number is punched on a plate attached to the left hand side of the engine body (illus. A),For easy reference, we suggest you write the number in the space provided in the owner’s personal data.

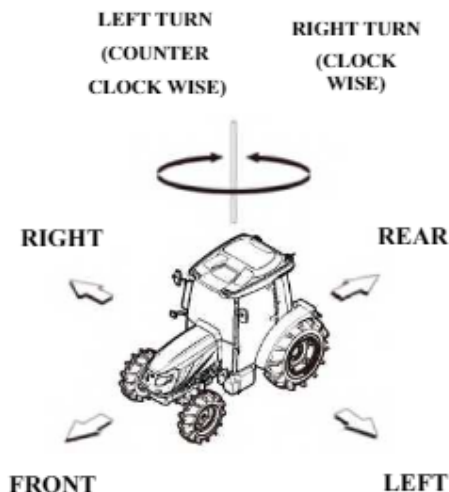

illustration B  
( Front, Rear,Left,Right Portion)

## **DESCRIPTION**

### **■ General construction**

The transmission case, Clutch, Clutch housing, Engine and Front Axle Support are bolted together to form a rigid unit .

### **■ Front Axle & Wheels**

The 4WD front axle is a center-pivot, reverse Eliot type.

The front wheel drive mechanism is incorporated as a part of the axle.

The front wheel drive power is taken off the rear transmission and transmitted to the differential in the front axle where the power is divided into right and left and to the respective final cases.

In the final cases, the transmitted revolution is reduced by the level gears to drive the front wheel.

The 4WD mechanism with level gears provides wider steering and greater durability.

### **■ Engine**

The tractors are fitted with fuel efficient **Turbo charged engines** with 3 cylinders of **2670 PST CAB** designed by Mahindra.

### **■ Clutch and Transmission**

Multi plate wet clutch pack 4.3”

Tractors with IPTO (Independent Power Take Off) are fitted with hydraulic Clutch Assy.

The transmission Gear box has 12 forward & 12 reverse speeds of **2670 PST CAB**.

Presently, Mahindra Tractors are fitted with constant mesh type gears.

### **■ Brakes**

Mahindra tractors are provided with independent disc brakes operated by two road travel.

A foot brake lever is fitted for parking.

### **■ Rear axle & Wheels**

This is mounted on ball bearings and is enclosed in removable housings which are bolted to the transmission case.

The rim & Disc fitted with Rear tires are bolted to the outer flange of the Rear Axle.

### **■ Hydraulic system & Linkages.**

Mahindra Tractors are fitted with Live (i.e. system is in operation even when clutch is disengaged.) independent, System.

Three point Linkages can be used for Category II types of implements.

■ **Steering**

It Steering consists of a Hydrostatic Power steering system, which has a hydraulic cylinder and tandem type hydraulic pump.

■ **Electrical System**

A 12 Volt Lead Acid Propylene Battery is used to activate the Engine through the Starter Motor and the Electrical system comprising Horn, and Head Lamp.

The side indicator Lamps, Plough Lamp, Brake Light, Gauge lamp, Hazard Lamp.

Generator or Alternator and, Fuse box also from part of the Electrical system.



**Warning**

When operating the tractor at High speed, Do not attempt to make sharp turns by using the brakes.

This may result in overturning the Tractor causing serious injury or DEATH.



## OWNER ASSISTANCE

We at Mahindra and your Mahindra Dealer/Distributor want you to be completely satisfied with your investment.

Normally any problems with your equipment will be handled by your Dealer/Distributor's Service Departments, however, misunderstanding can occur.

If you feel that your problem has not been handled to your satisfaction, we suggest the following.

Contact the owner or General Manager of the Dealership, explain the problem, and request assistance. When additional assistance is needed, your Dealer/Distributor has direct access to your office.

If you cannot obtain satisfaction by doing this, contact the Mahindra. Office and provide them with;

- Your name, address and telephone number
  
- Model and Tractor serial number
  
- Dealer/Distributor Name & Address
  
- Machine purchase date and Hours used
  
- Nature of problem

Before contacting the Mahindra office, be aware that your problem will likely be resolved at the Dealership using the Dealer's/Distributor's facilities, equipment and personnel.

So it is important that your initial contact be with the Dealer/Distributor.

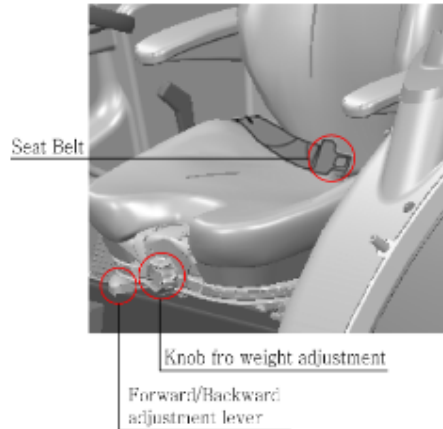

**NOTE:** Do not use solvents to clean the seat. Use warm water with a little detergent added.

Before operating a Tractor it is important to adjust the seat to the most comfortable position & check whether it is properly locked in its position.

Figure 1 identifies the seat fitted to your Tractor.

**FOR SLIDING SEAT**

To select Seat position, move Adjusting lever and slide Seat closer to or away from Dash panel and controls.

 <b>Danger</b>	<p>Check whether the seat is properly locked in its position before driving the tractor.</p>
--	--

 <b>Danger</b>	<p>Always use the seat belt when the ROPS is installed. Do not use the seat belt if a foldable ROPS is down or there is no ROPS. Check the seat belt regularly and replace if frayed or damaged.</p>
--	--

## SAFETY INSTRUCTIONS

### RECOGNIZE SAFETY INFORMATION

This symbol means **ATTENTION! YOUR SAFETY IS INVOLVED.** The message that follows the symbol contains important information about safety. Carefully read the message.



### SIGNAL WORDS.

A signal word—DANGER, WARNING OR CAUTION—is used with safety alert symbols. DANGER identifies the most serious hazards. Safety signs with signal Word —DANGER OR WARNING—are typically near specific hazards. General precautions are listed on CAUTION safety signs.



DANGER



WARNING



CAUTION

### READ SAFETY INSTRUCTION

Carefully read all safety instructions given in this manual for your safety. Tempering with any of the safety devices can cause serious injuries or death. Keep all safety signs in good condition. Replace missing or damaged safety signs.

Keep your tractor in proper condition and do not allow any unauthorized modifications to be carried out on the Tractor, which may impair the function/safety and affect Tractor life.

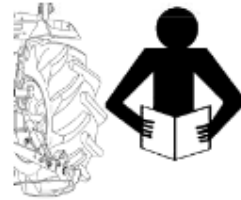

### PROTECTION for CHILDREN

Keep children and others away from the Tractor while operating.

#### BEFORE YOU REVERSE

- Look behind the Tractor for children.
- Do not let children ride on the Tractor or any implement.



#### USE OF ROPS AND SEAT BELT

The Roll Over Protective Structure (ROPS) has been certified to industry and/or government standards. Any damage or alteration to the ROPS, mounting hardware, or seat belt voids the certification and will reduce or eliminate protection for the operator in the event of a roll-over. The ROPS, mounting hardware, and seat belt should be checked after the first 100 hours of Tractor use and every 500 hours thereafter for any evidence of damage, wear or cracks. In the event of damage or alteration, the ROPS must be replaced prior to further operation of the Tractor.

The seat belt must be worn during machine operation when the machine is equipped with a certified ROPS.

Failure to do so will reduce or eliminate protection for the operator in the event of a roll over.



#### PRECAUTION TO AVOID TIPPING

Do not drive where the Tractor could slip or tip.

Stay alert for holes and rocks in the terrain, and other hidden hazards.

Slow down before you make a sharp turn.

Driving forward out of a ditch or mired condition could cause Tractor to tip over backward. Back out of these situations if possible.

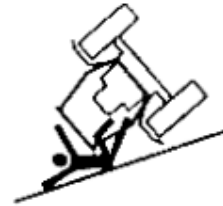

#### PARK TRACTOR SAFELY

Before working on the Tractor ;

Lower all equipment to the ground.

Stop the engine and remove the key.



#### KEEP RIDERS OFF TRACTOR

Do not allow riders on the Tractor.

Riders on Tractor are subject to injury such as being stuck by foreign objects and being thrown off of the Tractor .



#### **HANDLE FUEL SAFELY-AVOID FIRES**

Handle fuel with care; it is highly flammable. Do not refuel the Tractor while smoking or near open flame or sparks.  
Always stop engine before refueling Tractors.  
Always keep your tractor clean of accumulated grease, and debris.  
Always clean up spilled fuel.



#### **STAY CLEAR OF ROTATING SHAFTS**

Entanglement in a rotating shaft can cause serious injury or death.  
Keep PTO shield in place at all times.  
Wear close fitting clothing. Stop the engine and be sure PTO drive is stopped before making adjustments, connections, or cleaning out PTO driven equipment.



#### **ALWAYS USE SAFETY LIGHTS AND DEVICES**

The use of hazard warning lights and turn signals are recommended when towing equipment on public roads unless prohibited by state or local regulations.  
Use the slow moving vehicle (SMV) sign when driving on public roads during both day & night time, unless prohibited by law

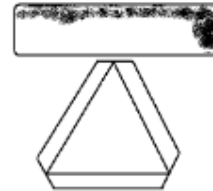

#### **PRACTICE SAFE MAINTENANCE**

Understand service procedures before doing work.  
Keep the surrounding area of the Tractor clean and dry.  
Do not attempt to service Tractor when it is in motion.  
Keep body and clothing away from rotating shafts.  
Always lower equipment to the ground. Stop the engine.  
Remove the key. Allow Tractor to cool before any work repair is attempted.  
Securely support any Tractor elements that must be raised for service work.  
Keep all parts in good condition and properly installed.  
Replace worn or broken parts. Replace damage/missing decals.  
Remove any buildup of grease or oil from the Tractor.  
Disconnect the battery ground cable(-) before making adjustments on electrical systems or welding on Tractor.



**AVOID HIGH-PRESSURE FLUIDS**

Escaping fluid under pressure can penetrate the skin causing serious injury. Keep hands and body away from pinholes and nozzles, which eject fluids under high pressure. If ANY fluid is injected into the skin. Consult your doctor immediately.

**PREVENT BATTERY EXPLOSIONS**

Keep sparks, lighted matches, and open flame away from the top of the battery. Battery gas can explode. Never check the battery charge by placing a metal object across the poles.

**PREVENT ACID BURNS**

Sulfuric acid in battery electrolyte is poisonous. It is strong enough to burn skin, cause holes in clothing and cause blindness if it comes in contact with your eyes.

For adequate safety always;

1. Fill batteries in a well-ventilated area.
2. Wear eye protection and acid proof hand gloves.
3. Avoid breathing direct fumes when electrolyte is added.
4. Do not add water to electrolyte as it may splash out causing severe burns.

If you spill acid on yourself;

1. Flush your skin with water.
2. Flush your eyes with water for 10-15 minutes.

Get medical attention immediately.

**SERVICE TRACTOR SAFELY**

Do not wear a necktie, scarf or loose clothing when you work near moving parts. If these items were to get caught, severe injury could result. Remove rings and other jeweler to prevent electrical shorts and entanglement in moving parts.



#### **WORK IN VENTILATED AREA**

Do not start the Tractor in an enclosed building unless the doors & windows are open for proper ventilation, as tractor fumes can cause sickness or death. If it is necessary to run an engine in an enclosed area remove the exhaust fumes by connecting an exhaust pipe extension.



#### **TRACTOR RUNAWAY**

1. The tractor can start even if the transmission is in the engaged position causing Tractor to runaway and subsequent serious injury to the people standing nearby the tractor.
2. For additional safety keep the transmission in neutral position, foot brake engaged and the PTO lever in disengaged position while attending to the Safety Starter Switch or any other work on Tractor.

#### **SAFETY STARTER SWITCH**

1. A clutch operated safety switch is provided on all Tractors which allows the starting system to become operational only when the Clutch pedal is fully pressed.
2. Do not By-pass this Safety Starter switch or work on it. Only Authorized Dealers are recommended to work on the safety starter switch.
3. On some models the Safety Starter switch is provided on the transmission High-low shifter lever and the PTO shifter lever. The tractor can be started only if the High-low shifter lever is in neutral position.



**Caution**

Safety Starter Switch is to be replaced after every 2000 hours or 4 years, whichever is earlier.

## SAFE OPERATION OF YOUR TRACTOR

The manufacturer of your tractor has made every effort to make it as safe as is humanly possible.

Beyond this point it is the responsibility of the operator to avoid accidents and we ask that you read and implement our suggestions for your safety.

**Ensure that only trained and competent operators use this tractor and ensure that they are fully conversant with the machine and aware of all its control and safety features.**

Operators should not operate the tractor or associated machinery while tired or untrained.

To avoid accidents please ensure that the operator wears clothing which will not get entangled in the moving parts of the tractor or machine and protect him or her from the elements.

When spraying or using chemicals, please ensure that clothing and protective equipment is worn that prevents respiratory or skin problems.

For full details consult the manufacturer of the chemicals.

To avoid lengthy exposure to noise ensure that ear protection is worn.

If adjustment to the tractor or machinery needs to be made, ensure the tractor or machine is turned off beforehand.

Use of certified Roll Over Protection Structure (ROPS) is a must while operating a tractor.

Use of seat belt is a must while operating a tractor.

In summary, ensure at all times that the safety of the operator and any other worker is paramount.



### **SAFETY TIPS DURING MAINTENANCE**

1. At least on a daily basis check all oil levels, water level in the radiator and electrolyte level in the battery and perform services according to the service schedule.
2. Ensure tire pressure is uniform and the correct pressure for the job being done is maintained.
3. Check to ensure all controls and preventative mechanisms of the Tractor and implement work correctly and effectively.
4. Ensure that an adequate set of the correct tools is available for maintenance and minor repairs.
5. Ensure that all service work and repairs are carried out on a flat area with a concrete or similar floor.

Do not carry out service work on a tractor until it is switched off, the parking brake applied and wheels chocked.

Where a tractor is started in a confined area, ensure that the area is well ventilated as exhaust gases are very harmful, and can cause death.

6. Do not work under raised implements.
7. When changing wheels or tires ensure that a suitable wheel stand is placed under the axle prior to removing the wheel and the wheels are chocked.
8. Where guards or shields need to be removed to perform a service or repair, ensure that the guard or shield is correctly reinstalled before starting the Tractor.
9. Never refuel near a naked flame or with an overheated engine.

Make sure to turn off Engine before refueling.

10. The cooling system operates under pressure.

Take care when removing the Radiator cap on a hot engine to prevent being scalded by steam or hot water.

Do not add water to the radiator when the engine is hot.

Add water to the radiator only after the engine cools down completely.

11. To prevent fires keep the tractor, including the engine.

Clean and free from inflammable material and well away from fuels and other inflammable material.

► **MOUNTING AND DEMOUNTING IMPLEMENTS**

- (1) Ensure that all mounting and removal of implements is done on safe flat ground.  
Ensure no one is between the Tractor and implement and do not get under the implement to avoid accidental injuries.
- (2) After mounting the implement, ensure that all sway chains are correctly adjusted and, where PTO shafts are used that the shaft is fitted and secured correctly.
- (3) Where heavy implements are used, ensure that the combination is well balanced or use a proper ballast to achieve balance.
- (4) Before leaving the tractor at any time, lower the implement, stop the PTO shaft where applicable, set the parking brake and switch off the engine.
- (5) While operating the implements with the PTO keep all bystanders away from any moving parts and do not attempt to make adjustments while the machine is running.
- (6) Only the driver should ride on the Tractor with the ROPS frame fitted and with the seat belt properly fastened.
- (7) Where young children are present, particular care should be taken and the tractor should not be moved until the whereabouts of all children is known.
- (8) Only trained operators should operate the Tractor and so taking care to ensure that other workers are not injured.  
In particular they should take care during dusty operations, which will reduce visibility substantially.
- (9) Never start the tractor unless the transmission is out of gear, the operator is in the seat and all round safety has been checked.
- (10) Only operate the tractor seated in the drivers seat and never turn or brake suddenly at high speed as this can cause a roll-over and serious injury or death.
- (11) When traveling on a public road ensure that the tractor and driver both meet all laws relating to safety and licensing.  
When traveling with wide implements use red flags on the extremities and observe all laws including escort requirements.
- (12) When operating under adverse conditions, hilly terrain or on bad ground, adjust the speed of the tractor to suit the conditions; safety comes first.  
Never drive down hill at high speed or with the transmission in neutral;  
Use the braking capacity of the engine as well as the service brakes.  
Do not try to change gear going up or down a steep slope, select the correct gear before starting.
- (13) Take care when traveling uphill with a heavy implement to ensure that it does not overbalance and tip up the front end.
- (14) Never remove or modify the seat belt.
- (15) Never remove, modify or repair the ROPS frame.

**PLEASE REMEMBER THAT A LITTLE BIT OF EXTRA CARE CAN PREVENT SERIOUS INJURY OR DEATH AND AVOID DAMAGE TO YOUR TRACTOR.**

**The following precautions are suggested to help prevent accidents.**

A careful operator is the best operator.

Most accidents can be avoided by observing certain precautions.

Read and take the following precautions before operating the Tractor to prevent accidents.

Tractors should be operated only by those who are responsible and properly trained to do so.

**■ The Tractor**

1. Read the operator's manual carefully before using the tractor.  
Lack of operating knowledge can lead to accidents.
2. Use an approved rollover bar and seat belt for safe operation.  
Overturning of a tractor without a rollover bar can result in death or injury.
3. **Do not remove ROPS (Roll Over Protective Structure).**  
Always use the seat belt.
4. A fiberglass canopy does not give any protection.
5. To prevent falls, keep steps and platform clear of mud and oil.
6. Do not permit anyone but the operator to ride on the Tractor.  
There is no safe place for extra riders.
7. Replace all missing, illegible or damaged safety signs.
8. **Keep safety signs clean of dirt and grease**

**■ Servicing the Tractor**

1. Keep the tractor in good operating condition for your safety.  
An improperly maintained Tractor can be hazardous.
2. Stop the engine before performing any service on the tractor.
3. The cooling system operates under pressure, which is controlled by the radiator cap.  
**It is dangerous to remove the cap while the system is hot.**  
First turn the cap slowly to stop and allow the pressure to escape before removing the cap entirely.
4. **Do not smoke when refueling the tractor. Keep away any type of open flame.**
5. The fuel in the injection system is under high pressure and can penetrate the skin.  
Unqualified persons should not remove or attempt to adjust a pump, injector, nozzle or any part of the fuel injection system.  
Failure to follow these instructions can result in serious injury.
6. **Keep open flame away from the battery or cold weather starting aids to prevent fire or explosions.**
7. **Do not modify or alter or permit anyone else to modify or alter this tractor or any of its components or any tractor functions.**

### ■ Operating the tractor

1. Before starting the tractor apply the parking brake, place the PTO (Power Take Off) lever in the “OFF” position, the hydraulic control levers in the downward position, the remote control valve levers in the neutral position( if fitted) and the transmission in neutral.
2. Do not start the engine or controls while standing beside the tractor.  
Always sit on the tractor seat when the engine is running or operating controls.
3. Safety starter switch.  
**In order to prevent the accidental starting of the tractor, a safety switch has been provided.**  
The starting system of the tractor is connected through this switch, which becomes operative only when the clutch pedal is depressed.  
On some models, the shuttle shifter lever and PTO button should also be in neutral position for completing the starting circuit.  
**Do not bypass the safety starter switch.**  
Consult Your Mahindra Tractor Dealer/Distributor if safety- starting switch malfunctions.
4. Avoid accidental contact with the gear shifter lever while the engine is running.  
Unexpected Tractor movement can result from such contact.
5. Do not get off or climb around the tractor while it is in motion.
6. Shut off the engine, remove the key and apply the parking brake before getting off the tractor.
7. Do not operate the tractor in an enclosed building without adequate ventilation.  
Exhaust fumes can cause death.
8. Do not park the tractor on a steep slope.
9. **If power steering or Engine ceases to operate, stop the tractor immediately.**
10. Pull only from the swinging draw bar or the lower link drawbar in the down position.  
Use only a drawbar pin that locks in place.  
Pulling from the tractor rear axle carriers or any point above the rear axle may cause the Tractor’s front end to lift.
11. If the front end of the tractor tends to rise when heavy implements are attached to the three-point linkage, install front end or front wheel weights.  
Do not operate the tractor with a light front end.
12. Always use the hydraulic position control lever when attaching equipment/implements and when transporting equipment.  
Be sure that the hydraulic couplers are properly mounted and will disconnect safely in the case of an accidental detachment of implement.
13. Do not leave equipment/implements in the raised position.
14. Use the flasher/ Turn signal lights and Slow Moving Vehicle (SMV) signs when driving on public roads during both day and night time, unless prohibited by law.
15. Dim tractor lights when meeting a vehicle at night.  
Be sure the lights are adjusted to prevent blinding the eyes of oncoming vehicle operators.
16. Emergency stopping instruction; If tractor fails to stop even after the application of brakes, shut off the engine, (turn off the key switch).

### ■ Driving the tractor

1. Watch where you are going especially at row ends, on roads, around trees and low hanging obstacles.
2. To avoid upsets, drive the tractor with care and at speeds compatible with safety, especially when operating over rough ground, crossing ditches or slopes, and when turning at corners.
3. Lock the tractor brake pedals together when transporting on roads to provide proper wheel braking.
4. Keep the tractor in the same gear when going downhill as used when going uphill.  
Do not coast or free wheel down hills.
5. Any towed vehicle and/or trailer whose total weight exceeds that of the towing Tractor, must be equipped with its own brakes for safe operation.
6. When the tractor is stuck or tires are frozen to the ground, back out to prevent upset.
7. Always check overhead clearance, especially when transporting the tractor.

### ■ Operating the PTO (Power Take Off)

1. When operating PTO driven equipment, shut off the engine and wait until the PTO stops before getting off the tractor and disconnecting the equipment.
2. Do not wear loose clothing when operating the power take-off or near rotating equipment.
3. When operating stationary PTO driven equipment, always apply the tractor parking brake and block the rear wheels from the front and rear side.
4. To avoid injury, always move down the flip part of PTO.  
Do not clean, adjust or service PTO driven equipment when the tractor engine is running.
5. Make sure the PTO master shield is installed at all times and always replace the PTO shield cap when the PTO is not in use.

### ■ NO Bio fuel.

1. Keep the equipment clean and properly maintained.
2. Under no circumstances should gasoline, alcohol or blended fuels be added to diesel fuel or explosive hazard.  
Such blends are more explosive than pure gasoline.  
In a closed container, such as a fuel tank.  
**DO NOT USE THESE BLENDS.**
3. Never remove the fuel cap or refuel the tractor with the engine running.
4. Do not smoke while refueling or when standing near fuel.
5. Maintain control of the fuel filler pipe when filling the tank.
6. Do not fill the fuel tank to capacity. Allow room for expansion.
7. Wipe up spilled fuel immediately.
8. Always tighten the fuel cap securely.
9. If the original fuel tank cap is lost, replace it with a genuine cap.  
A non approved cap may not be safe.
10. Do not drive equipment near open fire.
11. Never use fuel for cleaning purposes.
12. Arrange fuel purchases so that winter grade fuel is not held over and used in the spring.

**N.B: It is suggested that after repairs if any of the Safety Decals/signs have been peeled off/defaced, the same may be replaced immediately in the interest of your safety.**

## DO'S AND DON'T'S

### **DO'S-For Better performance**

- DO**-Ensure that safety shields are in place and in good condition.
- DO**-Read all operating instructions before commencing to operate Tractor.
- DO**-Carry out all maintenance tasks without fail.
- DO**-Keep the air cleaner clean.
- DO** -Ensure that the correct grade of lubricating oils is used and that they are replenished and changed in at the recommended intervals.
- DO**-Fit new sealing rings when the filter elements are changed.
- DO**-Watch the oil pressure gauge or warning light and investigate any abnormality immediately.
- DO**-Keep the radiator filled with clean water and in cold weather use an anti-freeze mixture. Drain the system only in an emergency and fill before starting the engine.
- DO**-Ensure that the transmission is in neutral before starting the engine.
- DO**-Keep all fuel in clean storage and use a filter when filling the tank.
- DO**-Attend to minor adjustments and repairs as soon as necessity is apparent.
- DO**-Allow the engine to cool before removing the radiator filler cap and adding water, remove the radiator cap slowly.
- DO**-Shift into low gear when driving down steep hills.
- DO**-Latch the brake pedals together when driving on a highway.
- DO**-Keep draft control lever fully down when not in use.



### **Don'ts-For safe operation**

- DON'T**-Run the engine with the air cleaner disconnected.
- DON'T**-Start the tractor in an enclosed building unless the doors and windows are open for proper ventilation.
- DON'T**-Operate the tractor or engine while lubricating or cleaning.
- DON'T**-Allow the tractor to run out of diesel fuel otherwise it will be necessary to vent the system.
- DON'T**-Tamper with the fuel injection pump., If the seal is broken the warranty becomes void.
- DON'T**-Allow the engine to run idle for a long period.
- DON'T**-Run the engine if it is not firing on all cylinders.
- DON'T**-Ride the brake or clutch pedal. This will result in the excessive wear of the brake lining, clutch driven member and clutch release bearing.

**DON'T**-Use the independent brakes for making turns on the highway or at high speeds.

**DON'T**-Refuel the tractor with the engine running.

**DON'T**-Mount or dismount from the right side of the tractor.

**DON'T**-Tamper the hydraulic control levers' upper limit stops.

**DON'T**-Use the draft control lever for lifting of implements.

**DON'T**-Start the engine with the PTO engaged.

**DON'T**-Use the governor Control Lever (Hand throttle) while driving on roads.

## SAFETY SIGNS

(Replace all missing, damaged or illegible signs)

### GENERAL SAFETY INFORMATION

IMPORTANT: This “General safety Information” should be kept with the machine at all times as reference data.

 <p><b>Caution</b></p>	<p>This symbol means <b>ATTENTION! YOUR SAFETY IS INVOLVED.</b></p> <p>The message that follows the symbol contains important information about safety. Follow recommended precautions and safe operating practice.</p>
---	---

### DECALS ON THE DASH COVER

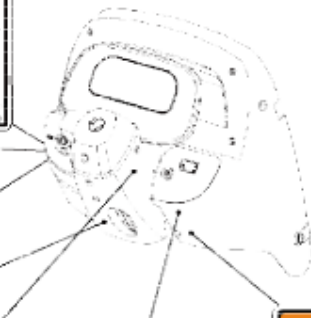

**WARNING**

- Start engine only from operators seat. If safety start switch is bypassed engine can start with transmission in gear.
- Do not connect or short across terminal on starter solenoid.
- Attach booster cables as shown on battery decal and operators manual.

Starting in gear causing runaway can result in serious injury.

**WARNING**

Quality. Each time you use your car, you should check the tires. If the tires are worn, you should replace them. Do not use tires with uneven tread patterns or uneven wear. This will affect your car's handling. Always use proper tire inflation. For more information go to [www.Polaris.com/guidebook](http://www.Polaris.com/guidebook)

**WARNING**

General and Restraint Seats

[www.Polaris.com/guidebook](http://www.Polaris.com/guidebook)

**WARNING**

Do not adjust the tilt handle when traveling.

1209-610-008-B

**WARNING**

Do not use the accelerator lever except working on the field.

1209-610-010-C

**WARNING**

Always apply the park brake when parking. Failure to do so can cause accidents and damages.

1209-610-009-D

**WARNING**

Brake pedals must always be locked together when driving on the highway. This will ensure uniform braking and provide maximum stopping ability. Sharp turns must only be made at slow speeds.

1209-610-011-E



## DECALS ON THE CABIN

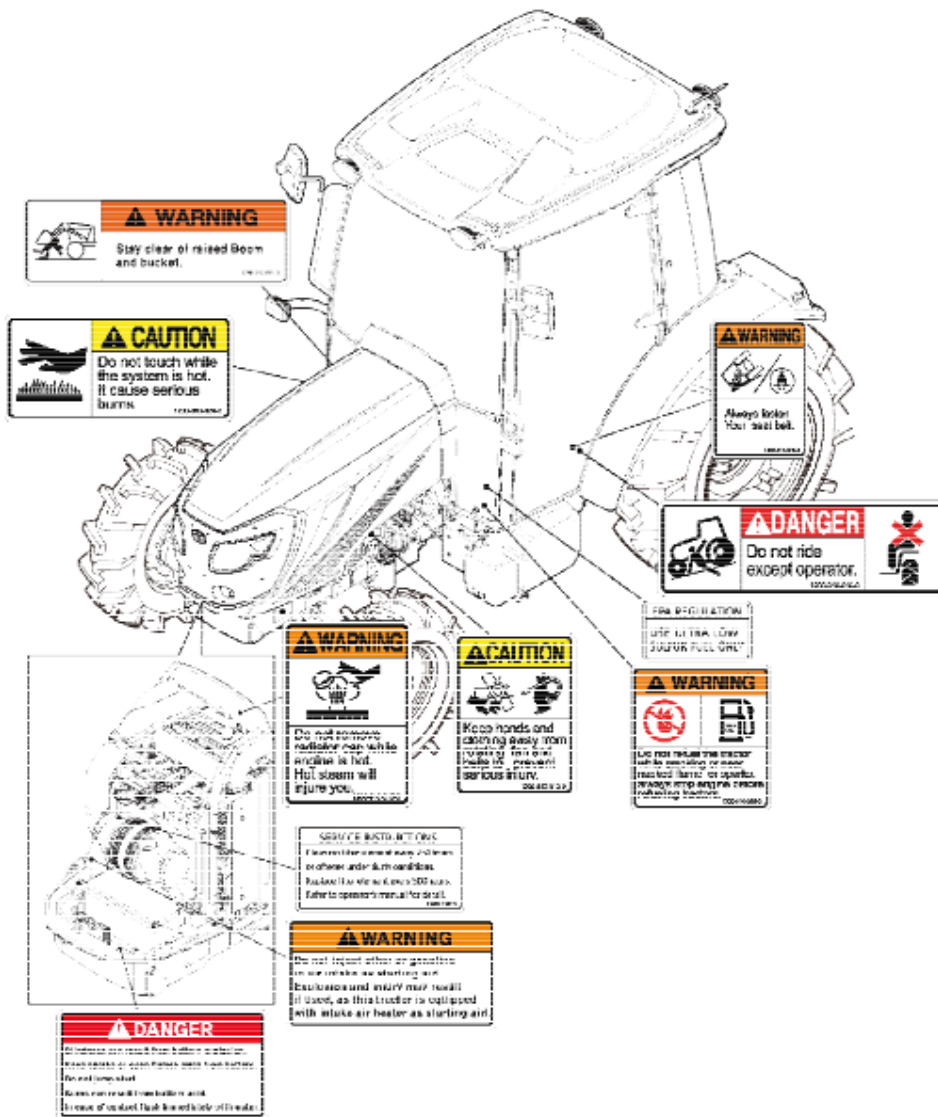

**DECALS ON THE CABIN**

**PERIODIC VENTILATION**

Periodic ventilation should be made to avoid suffocation while heating and air conditioning is used. Sleeping in the cab is prohibited.

**WARNING**

Never use the diff-lock at high speed or on the road as this can cause rollover and injury.

**WARNING**

Do not use the accelerator lever except working on the field.

**WARNING**

Push the button to lock position with the joystick lever in neutral whenever the loader is not in operation.

**WARNING**

Always use the hitch to lock when  
 1. Traveling on the road.  
 2. Reversing. Do not use it to hitch up.  
 3. Making adjustments to the hitch.  
 Button drooping of an implement can cause serious injury or death.

**WARNING**

Attach implements and trailers to the tractor only using the prescribed drawbar or hitch.

**DANGER**

Rotating driveline contact can cause death.  
**KEEP AWAY!**  
 Keep all driveline, tractor and equipment shields in place during operation.

**Speed Table**

Gear	1	2	3	4	5	6	7	8	9	10
1st	1.5	2.0	2.5	3.0	3.5	4.0	4.5	5.0	5.5	6.0
2nd	2.5	3.5	4.5	5.5	6.5	7.5	8.5	9.5	10.5	11.5
3rd	3.5	5.0	6.5	8.0	9.5	11.0	12.5	14.0	15.5	17.0
4th	5.0	7.0	9.0	11.0	13.0	15.0	17.0	19.0	21.0	23.0
5th	7.0	10.0	13.0	16.0	19.0	22.0	25.0	28.0	31.0	34.0
6th	10.0	14.0	18.0	22.0	26.0	30.0	34.0	38.0	42.0	46.0
7th	14.0	19.0	24.0	29.0	34.0	39.0	44.0	49.0	54.0	59.0
8th	19.0	25.0	31.0	37.0	43.0	49.0	55.0	61.0	67.0	73.0
9th	25.0	32.0	39.0	46.0	53.0	60.0	67.0	74.0	81.0	88.0
10th	32.0	40.0	48.0	56.0	64.0	72.0	80.0	88.0	96.0	104.0

**Inter/Damper air Ventilation**

- Always use the inter/damper air ventilation system.
- For additional information, see the operator's manual.

**WARNING**

Do not use the range shift lever at 'H' position when driving backward.

**WARNING**

Adjust Drive Response with Quick Release Knob

The quick release knob is a measurement for the amount of force needed to disengage the PTO. The knob is located on the right side of the tractor. The knob is used to adjust the PTO disengagement force. The knob is used to adjust the PTO disengagement force. The knob is used to adjust the PTO disengagement force.

**WARNING**

Push the button to lock position with the joystick lever in neutral whenever the loader is not in operation.

**WARNING**

Always use the hitch to lock when  
 1. Traveling on the road.  
 2. Reversing. Do not use it to hitch up.  
 3. Making adjustments to the hitch.  
 Button drooping of an implement can cause serious injury or death.

**WARNING**

Attach implements and trailers to the tractor only using the prescribed drawbar or hitch.











**DANGER**

Rotating driveline contact can cause death.  
**KEEP AWAY!**  
 Keep all driveline, tractor and equipment shields in place during operation.

Part Name	Part No.	Quantity	Notes
Inter/Damper Air Ventilation	1000000000	1	
Quick Release Knob	1000000000	1	
Joystick Lock Button	1000000000	1	
Diff-Lock Lever	1000000000	1	
Accelerator Lever	1000000000	1	
Range Shift Lever	1000000000	1	
Hitch Lock Button	1000000000	1	
Inter/Damper Air Ventilation	1000000000	1	

**UNIVERSAL SYMBOLS**

Some of the universal symbols are shown below with an indication of their meaning

	Engine speed (rev/minX100)		Pressured- open slowly		Corrosive substance
	Hours, recorded		Continuous variable		"Tortoise" Slow or minimum Setting
	Engine coolant temperature		Warning		"Hare" fast or maximum setting
	Fuel level		Hazard warning		Transmission oil pressure
	Engine Stop control	<b>N</b>	Neutral		Turn signal
	Lights		Fan		Transmission oil temperature
	Horn		Power take off engaged		Parking brake
	Engine oil pressure		Power take off disengaged		Work lamps
	Air cleaner filter contamination		Lift arm/raise		Differential lock
	Battery charge		Lift arm/lower		See operator's manual
	Malfunction indicator Lamp	<b>CHK ENG</b>	Check engine		Cruise

# Controls, Instruments And Operations

The following pages in this section detail the location and function of various instruments, switches and controls on your Tractor.

Even if you operate other Tractors, you should read through this section of the manual and ensure that you are thoroughly familiar with the location and function of all the features of your New Tractor.

Do not start the engine or attempt to drive or operate the Tractor until you are fully accustomed to all the controls.

It is too late to learn once the Tractor is moving.

If in doubt about any aspect of the operation of the tractor consult your Mahindra Tractor Dealer/Distributor.

Particular attention should be paid to the recommendations for running-in to ensure that your tractor will give the long life and dependable service for which it was intended.

## DESCRIPTION OF TRACTOR CONTROLS

### INSTRUMENT AND SWITCHES

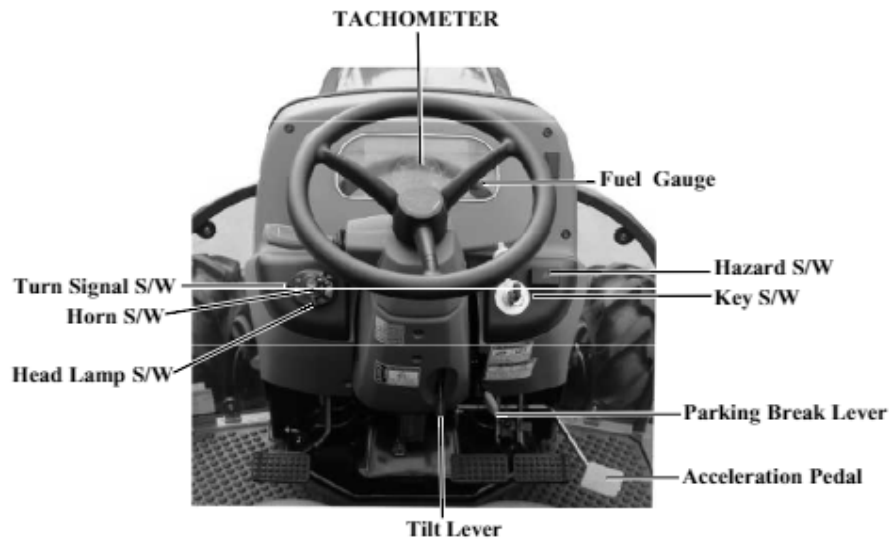

#### ► MAIN SWITCH (KEY SWITCH)

[OFF] - The key can be inserted or removed

[ON] - The electric circuit is on & preheat function

[START] - The starter motor is engaged.

When the key is released it will return to the ON position

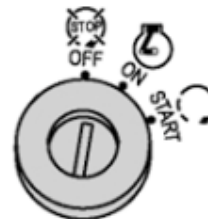

#### ► HEAD LAMP, TURN SIGNAL SWITCH AND HORN

##### ■ HEAD LAMP SWITCH

High and low beam are operated on the main switch

Position ①. Low beam

Position ②. High beam

##### ■ TURN SIGNAL SWITCH

Pull the turn signal lever down to signal a left turn.

Push the turn signal lever up to signal a right turn.

##### ■ HORN

Push the Red button.

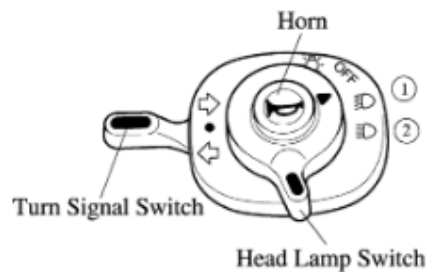

► **HOUR METER**

The hour meter consists of digits with the last digit indicating 1/10<sup>th</sup> of an hour.



► **TACHOMETER**

This meter shows the revolutions of the engine and the PTO shafts as well as the travel speed in top gear.



► **FUEL GAUGE**

This indicates the amount of fuel while the main switch is in the "ON" position.

F – Full

E - Empty



► **WATER TEMPERATURE GAUGE**

Shows the water temperature with the ignition switch ON.

C is low to normal temperature

H is high temperature

If the pointer is in the red H segment the engine is overheating.

Refer to this book to rectify the problem.



► **HAZARD S/W**

Push the hazard switch once to operate the hazard warning light. (Left and right turn indicators flash).



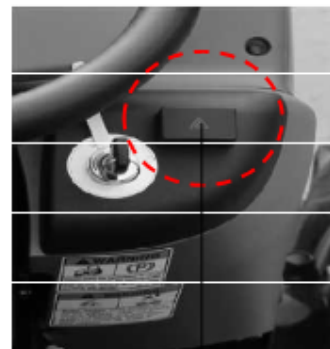





Push the hazard switch again to switch off the hazard warning lights.



HAZARD S/W







► WARNING LIGHTS



	High beam lamp is operated on the combination switch.
	Low beam lamp is operated on the combination switch
	Parking brake is operated when the footbrake is engaged.
	<b>PTO Lamp</b> Shows the revolution of PTO. Refer to monitor lamp on Page 32
	<b>Fuel Level Warning Lamp</b> If it comes on while the engine is running, fill the tank with fuel.
	<b>Oil pressure lamp</b> Will go out as soon as the engine starts if the oil pressure is correct. If it comes on while the engine is running, stop the engine and get expert advice.
	<b>Charge lamp</b> This light will go off as soon as the engine starts to run to indicate that the alternator is charging.  (Please note, as a broken fan belt can cause the light to come on, please stop the engine as overheating can occur if not rectified immediately)
	Glow signal lamp indicates preheating.

► WARNING LIGHTS



	<p><b>Water in fuel warning lamp :</b> When a certain amount of water is collected in the fuel filter, this lamp comes on. In this case, stop the engine immediately and drain water from the fuel filter.</p>
	<p><b>Air cleaner filter contamination indicator</b> This comes on when the air cleaner is clogged by foreign materials. When this comes on, Open the cover and clean the inside of the cleaner. Also, blow air through the filter in the Direction of intake air to clean it or replace the filter with a new one.</p>
	<p><b>Cruise Control Lamp</b> is operated on when cruise control is engaged. (Only HST tractor)</p>
	<p><b>Engine Check</b> It comes on when the engine is malfunctioning.</p>
	<p><b>Coolant temperature warning lamp</b> If this lamp comes on, coolant is overheated.</p>
	<p><b>Malfunction indicator lamp</b> This lamp comes on when the ignition key is turned to the "ON" position and goes off after The engine starts. This means that the warning light system is operating properly.</p>



### ■ PTO LAMP

on the dash panel indicates the state of the PTO shaft.

1. If the monitor glows: The PTO is rotating
2. If the monitor is off: The PTO is off



PTO Lamp

### ■ PTO button

To use the independent PTO, pull the lever up.

To use PTO - Pressing + Turning clockwise  
To stop PTO - Pressing



### Warning

1. If working on hard soils, pavements with a rotary implement the PTO ON/OFF switch must be put to the OFF position to stop the PTO from rotating, If this is not done, the rotating blades of the implement will push on the hard ground below and in turn push the tractor toward, causing accidents which can lead to serious injuries or death.
2. Extra precaution must be taken to clear the area of bystanders/onlookers when using PTO driven implements. The rotating blades of the implements can cause serious injuries on contact.
3. In no case should the specified rotating speeds indicated by the implement manufacturer be exceeded, as the same can lead to serious damage to the tractor/equipment and can lead to serious injuries to persons around.

### ■ RPM Dial

Dial to control the engine speed

- Turning it clockwise (toward the rabbit) increases the speed.
- Turning it counterclockwise (toward the tortoise) decrease the speed

### ■ Adjust Shuttle Response With Black Rotary Knob

The middle knob position is recommended for most applications.

- To shuttle smoothly : Rotate the knob towards the tortoise.
  - To shuttle aggressively : Rotate the knob towards the hare.
- Repeat above until desired shuttle response is achieved.

The three black buttons are for “dealer only” shuttle and inching Pedal adjustment.

Contact your dealer for additional adjustment.

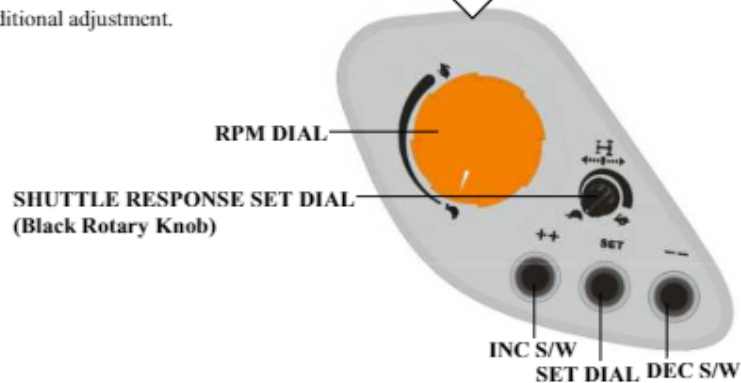

#### Warning

Do not operate the throttle dial unless working in a field to avoid accidents by over speeding.



#### Caution

If the dial's engine speed setting is lower than the throttle pedal's depressed position, the dial is overridden.

### ■ Cluster displaying mode change(MPH ↔ KPH)

- Start Key ON position and within 10 seconds, press ++Button simultaneously at least for 3 seconds, speed unit will be changed with buzzer sound and display unit on cluster during driving.

TRACTOR CONTROLS

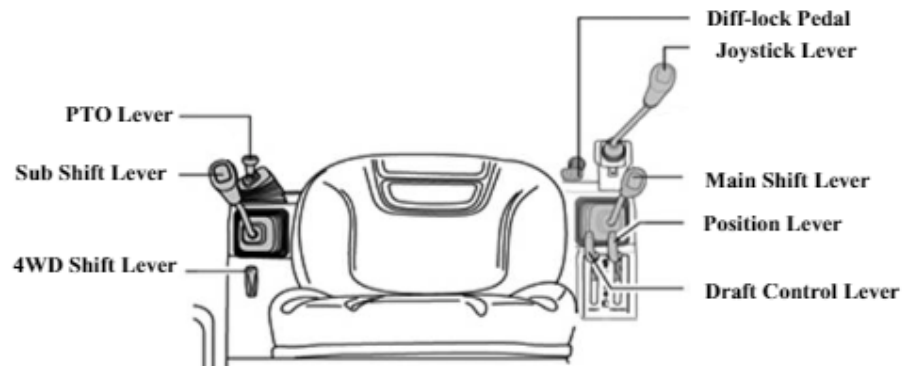
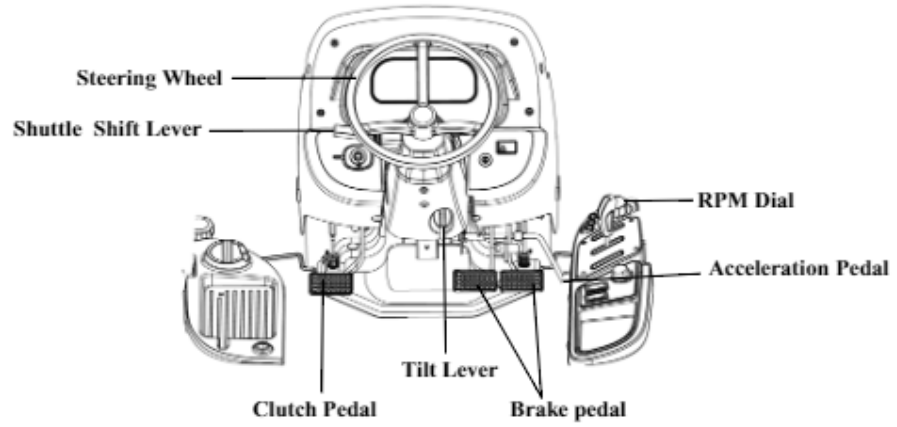

► **CLUTCH PEDAL**

When the clutch pedal is pressed on models with mechanical transmissions, drive is disengaged and the gear range and forward or reverse travel can be selected. When moving off, smoothly release the pedal to set the tractor moving.

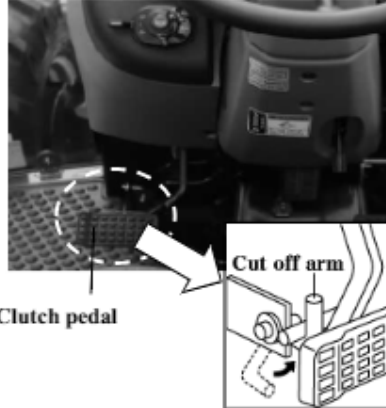

► **CLUTCH CUT- OFF ARM**

For the long term storage of the Tractor it is possible to latch the clutch in the disengaged position. Push the clutch down and engage the latch to hold it there.

 <p><b>Warning</b></p>	Do not attempt to start engine when this arm is being used.
---	---

► **BRAKE PEDAL**

Right and left brake pedals are provided to assist in turning the tractor in the field.

 <p><b>Caution</b></p>	A connecting latch is provided to connect the right and left brake pedals for high speed or road use. In the interest of safety always use it on the road or at high speed as using one side only can cause rollovers. When servicing the tractor ensure that the adjustment on both sides is the same.
---	---

► **ACCELERATION PEDAL**

This pedal can override a fixed hand throttle setting

► **PARKING BRAKE LEVER**

Connect the brake pedals, push them down while pulling the park brake up to engage. Press the parking brake pedal and push the Brake pedal to release.

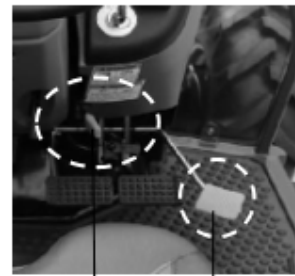

 <p><b>Important</b></p>	Traveling with the parking brake on will damage the brakes.
---	---



► **Shuttle Shift Lever**

This device is used to select the driving direction between the forward and reverse directions.

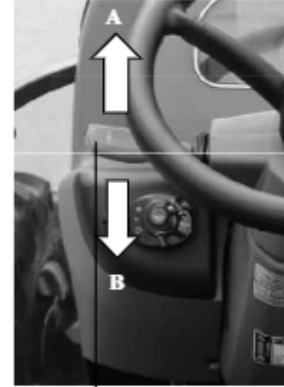
- Set it in the neutral position unless driving.
- (A) Move the switch up and push the lever away from the driver engages forward.
- (B) Move the switch up and push the lever towards the driver engages reverse.



**Shuttle Shift Lever**

 <b>Warning</b>	Operate after stop of Tractor.
 <b>Warning</b>	Before starting the engine, set the shuttle shift lever in the neutral position and depress the clutch pedal fully to avoid an accident by abrupt starting off.
<b>NOTE</b>	The shuttle shift lever consists of electric components, so forcible operation can damage the lever. The vehicle cannot be driven forward or backward while the parking brake is activated.

► **MAIN GEAR LEVER**

This lever can be shifted by using the clutch, both when the tractor is stationary or mobile.

It is located on the RHS of the driver seat.

► **SUB GEAR LEVER (LINEAR SHIFT LEVER)**

Operate the sub gear lever using the clutch to select the appropriate speed for different applications.

It is located on the LHS of the driver



**Main gear lever**



**Sub gear lever (Linear shift lever)**

 <b>Important</b>	<p>Avoid damage!            Select the proper speed range and gear for the job.</p> <ul style="list-style-type: none"> <li>• The machine maybe operated in any gear with engine speeds at 950-2600 rpm. Within these limits, the engine can be placed under varying load operations.</li> <li>• Never overload the engine by lugging machine at low idle speeds.</li> <li>• Raise engine speed to the match expected loads. If a slight increase in engine rpm occurs simultaneously with moving the hand throttle lever forward, the engine is not overloaded.</li> </ul>
----------------------	--

► The Main shift lever provides four speed positions. The Sub shift lever provides 3 ranges.

The Shuttle shift lever controls travel direction.

Use all three levers in different combinations to achieve 12 forward and 12 reverse speeds.

Machine motion must stop and the clutch pedal must be depressed before changing ranges.

Gear may be changed while machine is in motion if clutch pedal is completely depressed.

 <b>Important</b>	<p>Do not operate gear levers without stopping the tractor &amp; without using the clutch.</p>
----------------------	--

► **TO AVOID PERSONAL INJURY:**

- When you leave the tractor, be sure to apply the parking brake and stop the engine
- In applying the brakes:
  - The torque of wheel axle is extremely high while creep speed is being used.  
Be sure to step down on the clutch pedal completely before applying the brakes, or they will not work.
  - When starting to operate the tractor, be sure to release the parking brakes. Misuse of the brakes may cause damage to the transmission and is therefore not acceptable to Mahindra for coverage under the warranty.

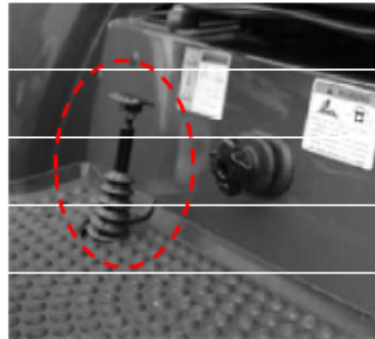

► **DIFF-LOCK PEDAL**

In the case of wheel slippage use the diff-lock by pushing down on the diff lock pedal.

To release it remove the foot from the pedal.



**Danger**

Tractor will be difficult to turn if the Diff-lock is engaged, ensure the lock is disengaged before turning the steering wheel.



**Important**

Do not use high engine RPM when engaging Diff lock. If the diff lock does not release after removing the foot from the diff lock pedal, brake with the left and right brake alternatively, until it gets released.



**Caution**

Never use the diff lock at high speed or on the road as this can cause roll over and injury.

► **FRONT WHEEL DRIVE LEVER**

In the ON position the front wheels are engaged and in the OFF position they are disengaged.

Engage & disengage the front wheel drive with the front wheels in the straight position and at low Engine RPM.

Use of front wheel drive improves traction performance.

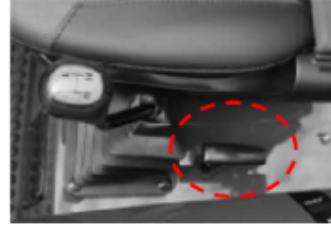

**Important**

Do not use front wheel drive at high speed or on the road as premature wear of components will result.



**important**

Always use the clutch when using the front wheel drive lever.

► **DRIVER'S SEAT**

To adjust the seat backwards and forwards lift the lever at the front of the seat and set it to the desired position



Seat Adjusting Lever

Cushion Control Knob

Seat Belt

► **TILT LEVER**

To adjust the inclination of the steering wheel with 3 stages and set it to the desired position.

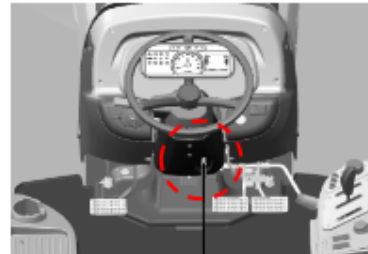

Tilt Lever



**Danger**

Ensure that the tilt lever has locked before moving the tractor.



### PTO GEAR SELECTION LEVER

Your tractor is equipped with a 1 Speed PTO to suit a range of applications and conditions.

MODEL	POSITION
	1 <sup>st</sup>
2670 PST CAB	540

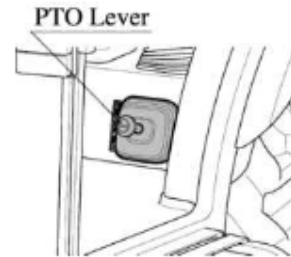

#### **Important**

Always use the clutch when engaging or disengaging the PTO or changing PTO speed. Let the PTO driven implement come to a complete stop before changing.



#### **Caution**

Do not operate any implement at a higher speed than as specified.  
When making adjustments to the implement stop the engine to avoid serious injury.  
When leaving the tractor, stop the engine, and remove the key. Set the parking brake.

### OPERATING THE HYDRAULICS.

The hydraulics are powered with an engine driven hydraulic pump and controlled with a position control lever mounted beside the driver.

#### **► POSITION CONTROL**

Implements can be raised and lowered with the hydraulic position control lever and can be stopped at any position by stopping the lever.

To ensure a consistent working depth the adjustable stop can be set to ensure that the implement returns to the same depth every time.

To raise the implement: Pull the lever back

To lower the implement: Push the lever forward.

#### **► DRAFT CONTROL LEVER**

Soil engaging implements can be set for precision work by using draft control.

By mounting the lever forward, the depth increases & by moving the lever backwards the depth increases.



Position Lever

Draft Lever



**Warning**

After finishing the work, always lower the implement to the ground and switch off the engine, Set the parking brake to avoid injuries and accidents .

**► LOWERING SPEED CONTROL KNOB FOR THE 3 POINT HITCH**

This knob controls the downward speed of the Hydraulic's three point linkage and is positioned at the front of the driver's seat.

To slow the downward speed- Turn the knob clockwise.

To increase the downward speed, turn the knob counterclockwise.  
To lock the knob, turn clockwise.

Do not over tighten the knob.

Adjusting Knob of Hydraulic decent Speed

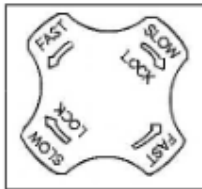
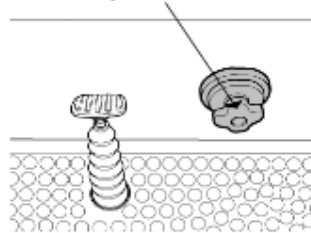

**Caution**

Always set the knob to lock when

- 1.Traveling on the road
- 2.Replacing tires or blades on an implement.
- 3.Making adjustments to an implement. Sudden dropping of an implement due to hydraulic problems can cause serious injury or death.

### **EXTERIOR HYDRAULIC LEVER**

Move the lever up or down and hold.  
This will raise or lower the implement  
(rotavator or hydraulic plow).

Spring type – Double-acting with Spring Important:

- Do not hold the lever in the “pull” or “Push” position once the remote cylinder has reached the end of the stroke, as this will cause oil to flow through the relief valve. Forcing oil through the relief valve for extended periods will overheat the oil.
- When Using the tractor hydraulic system to power front loader, do not operate the boom and bucket cylinders simultaneously.

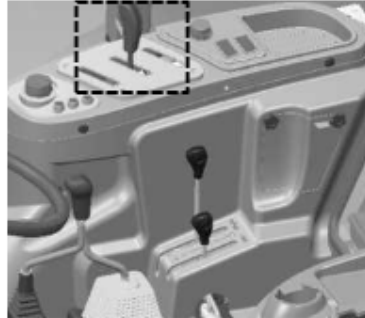

### **► REMOTE HYDRAULIC CONTROL VALVE COUPLER CONNECTING AND DISCONNECTING.**

#### **■ Connecting**

- 1.Clean both couplers.
- 2.Remove dust plugs.
- 3.Insert the implement coupler to the tractor hydraulic coupler
- 4.Pull the implement coupler slightly to make sure couplers are firmly connected.

#### **■ Disconnecting**

- 1.Lower the implement first to the ground to release hydraulic pressure in the hoses.
- 2.Clean the couplers.
- 3.Relieve pressure by moving hydraulic control levers with the engine shut off. Pull the hose straight from the hydraulic coupler to release it.
- 4.Clean oil and dust from the coupler, then replace the dust plugs.



### **► JOY STICK LEVER**

- This simple joystick lever can control the use of a front-end loader.  
And lift-retract, dump-rollback smoothly and act as one handle lever.
- To raise the front end loader : pull the lever to lift position.
  - To lower the front end loader : push the lever to retract position.
  - To rollback the bucket : pull the stick to rollback position.
  - To dump the bucket : push the stick to dump position.

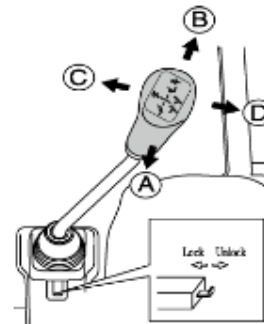

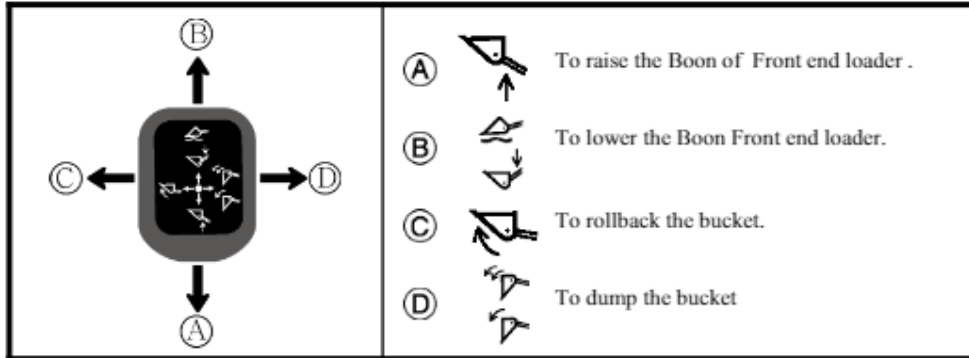

► SAFETY IMPLEMENT FOR JOYSTICK LEVER

This simple **Safety** locking system can lock the joystick by pushing the button and unlock by pulling.

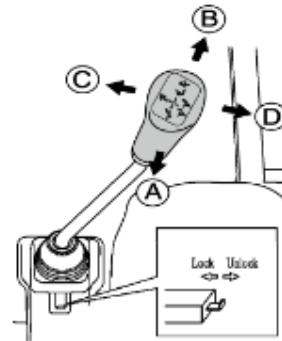

<p><b>Warning</b></p>	<p>Hydraulic fluid escaping under pressure can have enough force to penetrate the skin. Hydraulic fluid may also infect a minor cut or opening in the skin. If injured by escaping fluid, see a doctor at once. Serious infection or reaction can result if medical treatment is not given immediately. Make sure all connections are tight and that hoses and lines are in good condition before applying pressure to the system. Release all pressure before disconnecting the lines or performing other work on the hydraulic system. To find a leak under pressure use a small piece of cardboard or wood. Never use hands.</p>
-----------------------	---

OPERATING THE 3 POINT LINKAGE (TPL)

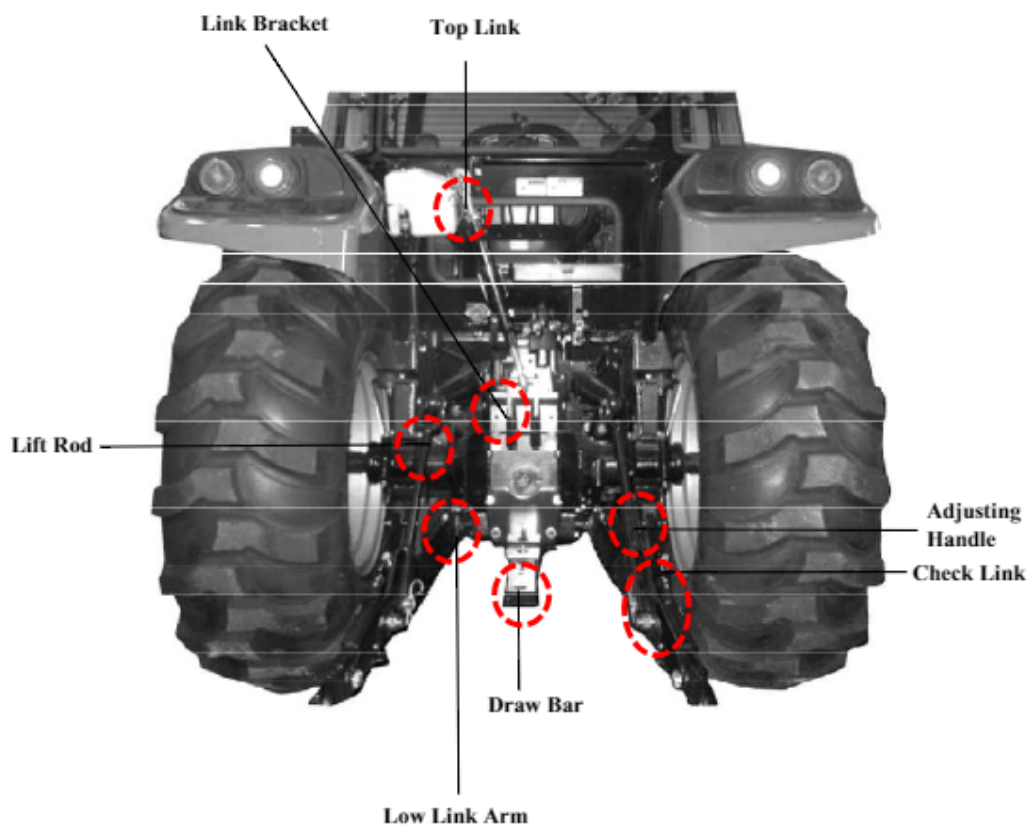

► **TELESCOPIC STABILIZERS ADJUSTMENT**

The stabilizers are intended for limiting or preventing implement side movement.

There should be no clearance (Position A) during implement transport and when working with grades, rollers mowers, seeders, drills and similar implements.

However, a slight play is necessary (Position B) when working with ploughs, harrows, ditchers, cultivators and the like:

As when working with “draft control”.

The length of stabilizers is adjusted by removing the pin and rotating the turn buckle barrel by which the threaded ends are interconnected.

► **ADJUSTMENT OF THE TOP LINK**

Lengthening or shortening the top link will change the angle of the implement.

The locating hole of the top link varies with the type of implement used.

The most common locations are the 1st and 2nd hole from the top.

1) For general implement :Use the Pin to “A” point

2) For Draft control :Use the Pin to “B” point

► **ADJUSTMENT OF LOWER LINK**

The adjustment is done with the adjusting handle on the Right hand Lift rod.

To shorten it, wind the handle clockwise and to lengthen it wind it counter clockwise.

When adjusted correctly hold the turn buckle with the stopper provided.

► **LOWER LINK (IF EQUIPPED EXTENDABLE TYPE)**

Push the point area and pull the end of the lower link to adjust the length of lower link.

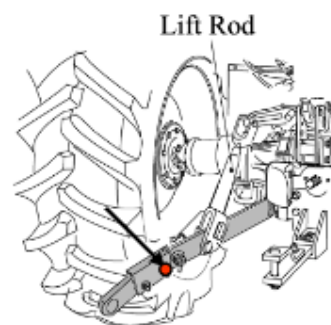
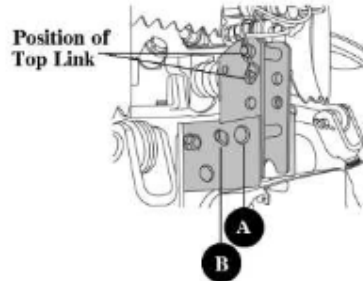
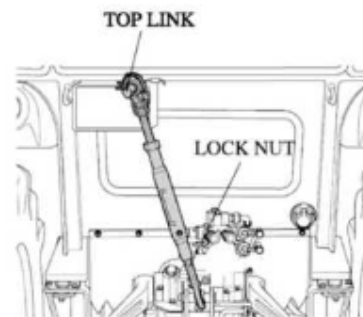
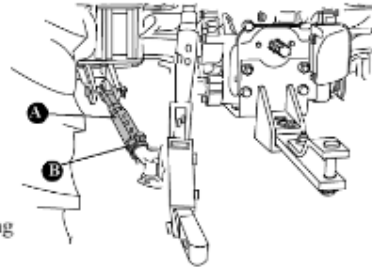

► **ADJUSTMENT OF THE LIFT LINK ON THE LOWER LINK**

For different applications change the position of the lift rod on the lower links as shown and insert the pin in the direction of the arrow.

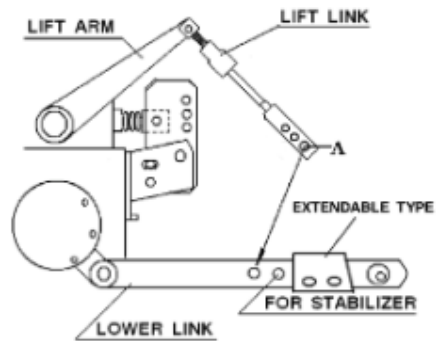

**Danger**

Only use drawbar to tow and keep the 3 point linkage in raised position when towing with the drawbar.  
Position can create unbalance causing the Tractor to roll-over & Result in death or serious injury.

► **MOUNTING IMPLEMENT**

If the PTO is used, remove the safety cover off the PTO shaft.

Adjust the yoke rod on the lower links to suit the implement in use.

Attach the left lower link, then attach the right lower link using the adjusting handle on the leveling box if required.

Attach the top link.

Attach the PTO shaft to the tractor if used, making sure that it is locked in place.

Adjust the check chains to suit the implement and tighten the locknuts.

To remove an implement reverses the procedure

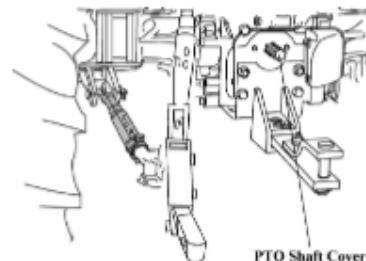

**Caution**

Do not attach a PTO shaft while the engine is running and ensure all safety shields are in place.

## DRIVING THE TRACTOR

### STARTING THE ENGINE

Before starting the engine carry out the pre-operational checks as set out on page 19.

- (1) Sit on the driver seat
- (2) Apply the footbrake.
- (3) Put the hydraulic lever in the down position.
- (4) Push down the clutch to activate the safety-starting switch.
- (5) Put the main gear lever in neutral.
- (6) Insert the ignition key and turn it on.
- (7) Ensure that the warning lights are working.
- (8) Ensure that all the warning lights are off with the engine running.



#### **Important**

Never turn the key to the start position while the engine is running as this can cause serious damage to the starter and engine flywheel.

Only engage the starter for a period of not more than 10 seconds.

If Engine does not start, rest the starter for about 20 seconds and try again for a maximum of 10 seconds. If the engine does not start after repeated attempts, refer to the fault tracing guide.



#### **Important**

Especially in cold weather, always allow the tractor to idle for a while to warm up & build up sufficient oil pressure to ensure normal operating temperature for longer engine life.

### STOPPING THE ENGINE

-After light work let the engine idle for a while and turn the key off.



#### **Important**

After long or heavy work allow the engine to idle for 5- 10 minutes and turn the key off.



### **WARMING UP**

When starting the engine allow it to warm up to operating temperature by allowing it to idle 5-10 minutes to ensure full lubrication and operating temperature.

Failure to do so can shorten engine life substantially.

#### **► WARMING UP IN COLD WEATHER**

Cold weather will change the viscosity of the oil, resulting in a reduced oil pumping capacity, which can cause damage to the engine if it is not warmed up correctly.

It also causes problems with the hydraulic system and the synchromesh in the transmission.

Correct times for warming up are:

<b>Temperature</b>	<b>Time for warming up</b>
Above 50°F	5~10 min.
50°F~32°F	10~20 min.
32°F~14°F	20~30 min.
14°F~-4°F	30~40 min.
Below -4°F	Over 40 min.

 <b>Important</b>	Ensure the handbrake (Foot brake) is on during the warming period. Failure to warm up correctly can result in problems.
---	--

When the engine is warm, push down the clutch and engage the main and auxiliary gear levers to the required position.

Push down on the brake pedals and release the handbrake.

Increase the engine revolutions and let out the clutch smoothly.

Only change gears with the main gear lever while moving and ensure that this is done with the full use of the clutch.

#### **► STORING ENGINE IN OPERABLE CONDITION FOR 3 MONTHS OR MORE**

When the engine is not operated during a storage period of three months or more, internal engine parts can rust and lose oil film. As a result, the engine can seize when it is started after storage.

To prevent such a rust, the engine must be operated periodically during storage.



**Caution**

Do not "ride" the clutch to control speed, use a lower gear.  
Do not travel with your foot on the clutch pedal.



**Danger**

Always connect the brake pedals when traveling on the road.  
Never tow anything except with the drawbar.  
Do not tow loads which are too large for the tractor's capacity to brake effectively especially in hilly terrain.  
Take special care when towing large or wide implements.  
Do not carry passengers.  
At all times observe local legislation and road rules.

#### TIGHT TURNS IN THE FIELD

Disconnect the latch connecting the left and right brake pedals to allow the use of individual pedals.

To make a tight turn use both the steering wheel and the brake pedal at the same time.

For a left turn use the left pedal and a right turn the right pedal.



**Caution**

Perform tight turns only at a slow safe speed.  
Doing so at a high speed can cause rollovers and very serious injury or death.

#### NORMAL BRAKING AND PARKING

Let the engine come back to idle and at the same time push in the clutch and brake simultaneously.

When the tractor has come to a halt, lower any implement to the ground, and put the main gear in neutral.

Apply the parking brake, stop the engine, and remove the key.



Illustration



**Caution**

Always apply the parking brake when parking.  
Failure to do so can cause accidents and damage.  
As an extra precaution when parking on a slope, chock the rear wheels.

### UPHILL STARTS ON A STEEP SLOPE

With the pedals connected together push down on the brake pedals and push down the clutch.

Set all gear levers to low and the throttle to medium engine speed.

Release the clutch and as it engages release the brake pedals.

Adjust the throttle to the required speed.

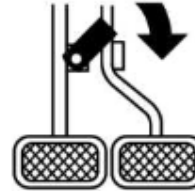

### ► **DRIVING DOWNHILL**

Use the engine's ability to brake when traveling downhill.

Never rely on the brakes only and never travel downhill with the gears in neutral.

 <b>Caution</b>	<p>When operating in hilly terrain the risk of the rollover is increased substantially, please drive with extra care.</p> <p>When towing trailers in hilly terrain ensure that they are equipped with brakes, use a lower gear to get maximum engine braking and do not change gears on a downhill run</p>
---	--

### OPERATION OF THE DIFF LOCK

While the diff lock is a very useful feature, care should be taken in its use as misuse can lead to dangerous situations.

The diff lock should only be used in situations where traction is lost on one of the rear wheels.

 <b>Warning</b>	<p>Use low engine revolutions when using the diff lock.</p> <p>If the diff lock does not release after removing the foot from the pedal use the left and right brake pedals in turn to release it.</p> <p>Do not try to engage or use the diff lock on tight turns as serious damage can result.</p>
---	--

### CHECK DURING DRIVING

Constantly monitor the warning lights on the dash and if any come on, stop the tractor to determine the cause.

If the **oil pressure light** comes on, check the oil level first of all.

If the oil level is OK, ask a qualified dealer to check the reason for the light coming on.

If the **alternator warning light** comes on, check all connections and ensure that the fan belt is not broken.

If all connections and the fan belt are intact, consult your dealer to determine the cause of the problem.



► **FUEL LEVEL WARNING LAMP**

To avoid excessive condensation in the fuel tank, refill it at the end of each day's work and ensure during the day that it does not drop to a low enough level where the fuel system will require bleeding to expel air in the system after refilling the tank.



► **COOLANT TEMPERATURE WARNING LAMP.**

If the gauge indicates that the engine is running hot, stop the tractor and check the coolant in the radiator.



► **TRAILER SOCKET** (Seven Terminal Electrical Socket type)

To operate the Electrical system of implements, trailer lighting, warning lamp etc.

Trailer Socket



 <b>Danger</b>	Allow the engine to cool down before opening the radiator as serious burns may result due to hot steam & boiling water.
--	---

Also check to ensure that the fins in the radiator core are not clogged or that the tractor has a broken or stretched fan belt.

 <b>Caution</b>	When traveling on public or farm roads connect both brake pedals and allow for the weight of any mounted implement to ensure that the unit is not unbalanced. Also allow for the width when passing other road users. Where fitted, use the hazard lights provided. Strictly follow the local traffic regulations.
---	---

 <b>Caution</b>	When operating near others with an implement attached take particular care to allow for the width of the implement and avoid accidents.
---	---

► **TRACK ADJUSTMENT**

As **2670 PST CAB** models of Mahindra are front wheel assist, the front track can be set in

The rear track can be set in \_\_\_\_\_ as illustrated.

**2670 PST CAB**

TYPE	DIVISION	TYRE	TREAD(inch)
AG	FRONT	9.5-20 Hi Trac Lug	60.9
	REAR	14.9-28 Hi Trac Lug	55.2
IND	FRONT	10.5/80-18 Contractor	63.2
	REAR	18.4-24 Industrial Tractor	54.5

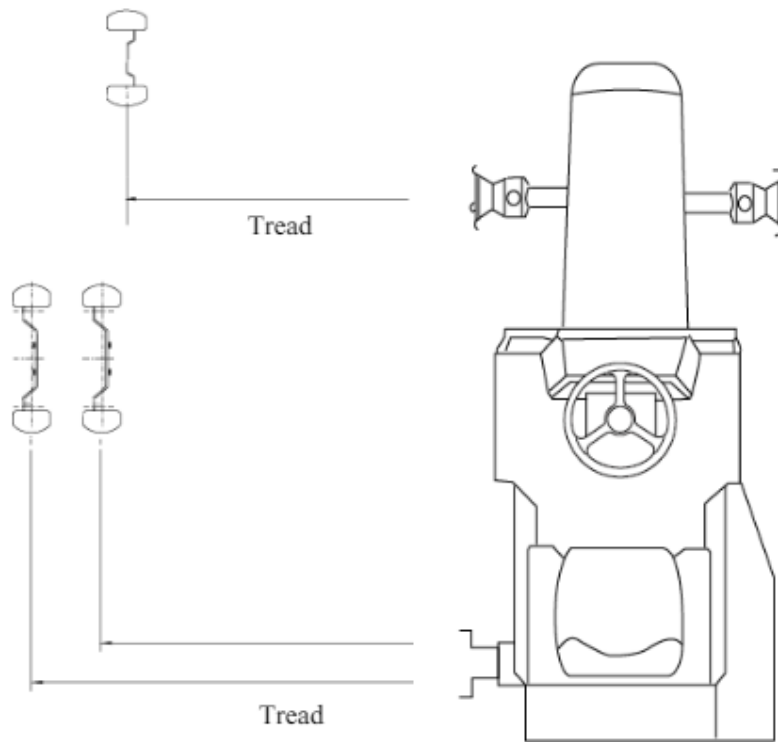

# **Lubrication & Maintenance**

This section gives full details of the service procedures necessary to maintain your Tractor at peak efficiency while the lubrication and maintenance chart provides a ready reference to these requirements.

## CHECKS AND SERVICE

### PRE-START CHECKS

To avoid problems, it is recommended that a range of checks be carried out daily before starting the tractor.

For full details of the items and frequency please refer to the tables on page 57,58 and 59.

#### ► ENGINE COOLANT

Remove the radiator cap and ensure that the coolant is up to the filler neck and that it is clean with the correct anti-freeze or anti corrosion inhibitor in it.

If the coolant is a rusty color, drain the system completely and refill with the correct mixture of water and anti-freeze or corrosion inhibitor.

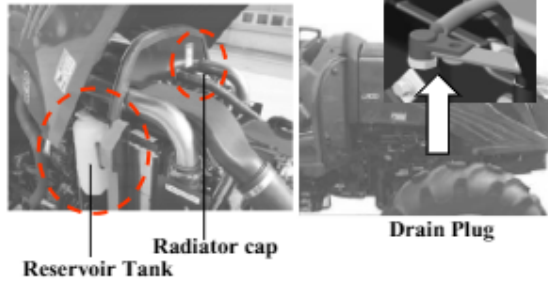

#### ► ENGINE OIL

Pull out the stick, wipe it and dip in the oil sump. Ensure that the oil level is between the upper and lower marks near the upper mark. If too low add oil, but never in exceed of 100hrs.

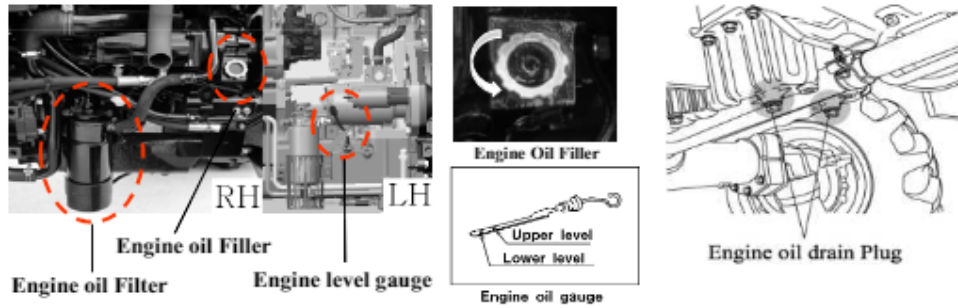

**Important**

Do not overfill the crankcase with oil.

#### ► TRANSMISSION OIL

Check the level with the dipstick on top of the transmission in rear of the seat.

If the level is low add oil through the filler hole.



**Caution**

Always ensure that you use the correct oil for topping up or oil changes

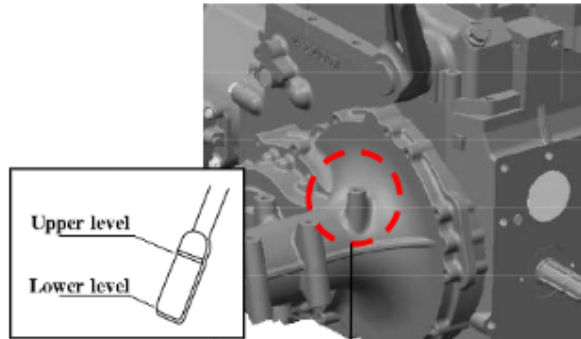

**Oil Lever Gauge**

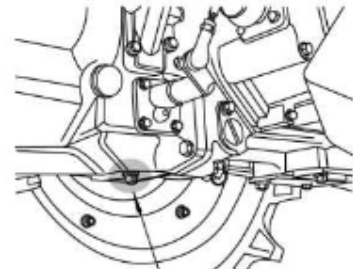

**Transmission oil drain Plug**

► **FUEL**

Use the fuel gauge to check the fuel level and top off if it is too low.

It is a good practice to refill the tank immediately after use to avoid condensation

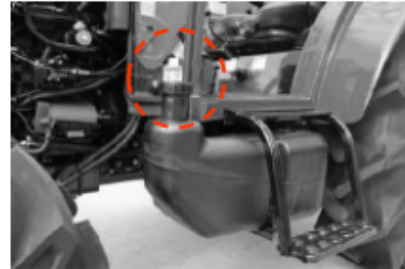

**Fuel Tank Cap**

► **TYRE PRESSURE**

The air pressure used in the tires has a direct bearing on the life of the tire and its performance in the field.

Ensure that the tire pressures are correct and in accordance with the table on page 91.

To make a visual judgment see the drawing on the right.



**Excess Standard Lack**

 <b>Important</b>	<p>It is strongly recommended that tire pressures are checked with a proper gauge only &amp; visual inspections are relied upon.</p>
----------------------	--

 <b>Danger</b>	<p>Excess tire pressure can cause accidents!</p>
-------------------	--



► **STEERING**

Ensure that the steering wheel does not have excessive free play.

► **BRAKE**

Ensure that the left and right brakes are adjusted correctly so they operate simultaneously.

The correct free play on the brake is 1.18-1.57 in (30~40 mm).

► **CLUTCH**

Ensure that the clutch is adjusted correctly.

Correct free play on the clutch pedal is 0.78-1.18 in (20~30mm).



Incorrect clutch adjustment can cause excessive wear and reduced tractor performance.

► **ELECTRICAL**

Check the operation of all gauge, switches, horn, lights and indicators.

► **DETACHING THE LOADER**

1. Detach the hydraulic hoses of loader.
2. Assemble the cap (PF3/8) with pipe comp (PF3/8).

► **INSTALLING LOADER**

1. Refer to installation manual of loader.



**Transmission oil Filter      Loader Valve**

**MAINTENANCE AND ADJUSTMENT SCHEDULE**

Periodic check and service table

○ Check, Top-up or adjust ● Replace

△ Clean or wash ★ Consult the service Dealer

Division	Item	Daily	Service interval(hour meter,mark)												Frequency	Comment					
			500	1000	1500	2000	2500	3000	3500	4000	4500	5000	5500	6000							
Engine	Engine oil & Cartridge	○																●	• Change Oil Level 10Hrs. Or Daily • Change every 500 Hrs. or 1 year	To correct level on the dipstick	
	Air cleaner	○						△											●		
	Radiator coolant	○																		Check daily top up if required	See page 67.
	Fuel	○																			Fill tank
	Fuel filter	○																	●	• Drain Water from Fuel Filters(every 15 days) • Change Fuel Filter(earlier, if required) Every 250Hrs.	Refer to E/G O/P
	Fan belt	○																		Check daily	Refer to E/G O/P
	Battery		○																	Check daily	
	Loose nuts and bolts	○																		Check daily	Tighten
	Radiator hose clamp	○																			Tighten if required



**Caution**

These intervals are for operation under normal conditions and need to be reviewed under severe conditions to a greater frequency.

**TRANSMISSION**

Division	Item	Daily	Service interval(hour meter,mark)												Frequency	Comment				
			500	1000	1500	2000	2500	3000	3500	4000	4500	5000	5500	6000						
Chassis	Trans mission oil	<input type="radio"/>	●						★								●	Every 500 hours or 12months after first 50 hours		
	Free play of clutch pedal	<input type="radio"/>																	Check daily	(0.78-1.18in)
	Free play of brake pedal	<input type="radio"/>																	Check daily	(1.18-1.57in)
	State of both brake pedals	<input type="radio"/>																	Check daily	Adjust so that both operate simultaneously and brake at the same time
	Operation of each lever	<input type="radio"/>																	Check daily	Smooth operation
	Free play of steering wheel	<input type="radio"/>																	Check daily	About 50mm (1.97 in) of wheel circumference
	Toe-in								★									★	Check every 300 hours	(0.08-0.24in)
	Grease in front wheel hub																		Grease every 900 hours	
	Check the steering wheel joint	<input type="radio"/>																	Adjust every 300 hours	
	Wheel nut fastening torque	<input type="radio"/>																	Check daily	Tighten if loose Front : 1600~1800 kgf-cm (116~130ft-lbs) Rear : 1600~1800kgf-cm (116 ~ 130 ft-lbs)
	Operation of the instrument	<input type="radio"/>																	Check daily	

Division	Item	Daily	Service interval(hour meter,mark)												Frequency	Comment			
			5	1	1	2	2	3	3	4	4	5	5	6					
			0	0	0	0	0	0	0	0	0	0	0	0			0		
Chassis	Adjustment of the throttle pedal																○	Check every 300 hours	
	Grease each nipple		○	○	○	○	○	○	○	○	○	○	○	○	○	○	○	Replenish every 50 hours (everyday in dusty conditions)	
	Loose bolts and nuts	○																Check daily	Tighten to proper torque
	Check the leakage of oil at the clutch chamber																	Check once a year with the lower plug pulled out	
	Hydraulic oil filter		●							★							●	Every 500 hours or 12 months after first 50 hours.	
	Oil of the 4WD front axle		●							★							●	Every 500 hours or 12months after first 50 hours	
	Check the electric wiring	○																Check every year	Without loose or broken terminals. Without damaged or missing wiring. Correctly clamped

## FILLING DIAGRAM & CAPACITY TABLE

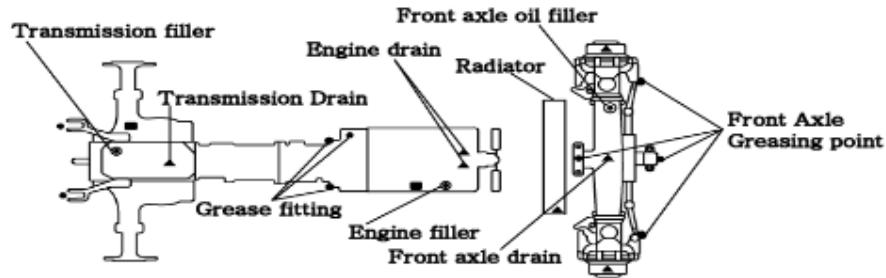

- Oil Filler hole
- Greasing point
- ▲ Drains
- Window

No.	Filling point	Fillings	Quantity Liter (gal.)
	MODEL		2670 PST CAB
1	RADIATOR	Fresh clean Water(L.L.C) with an antifreeze, mixed in ratio of minimum 50%	9.5ℓ(2.5 US gal)
2	ENGINE	API : CJ-4 grade Above:25°C(77°F)...SAE30 or 10W-30 0°C to 25°C(32°F to 77°F)...SAE20 or 10W30 Below 0°C(32°F)...SAE 10W or 10W-30 MAHINDRA HEAVY DUTY SAE 15W-40	8.5ℓ (2.25 gal)
3	TRANSMISSION CASE	API GL-4 Grade Tractor transmission and hydraulic oil Below -4°F(-20°C) ISO VG32 Above -4°F(-20°C) between ISO VG46 and 68	42ℓ(11 US gal)
4	FRONT AXLE	(API GL-4 Grades) SAE 80W/90 MAHINDRA UNIVERSAL TRACTOR FLUID	16.4ℓ(4.33 US gal)
5	FINAL DRIVE CASE(B)	(API GL-4 Grades) SAE 80W/90 MAHINDRA UNIVERSAL TRACTOR FLUID	
6	Clutch pedal shaft	-	-
7	BALL JOINT	Grease	As required
8	FUEL TANK	Diesel fuel	70ℓ(18.5 US gal)

► **RECOMMENDED TRANSMISSION OIL**

① MAHINDRA UNIVERSAL TRACTOR FLUID

Opening method of each cover

► **Opening method of Hood**

- 1) Slide the hook to the side. Then, the hood opens with a clicking sound.
- 2) Lift the hood with the hands. Then, the hood is automatically opened and fixed by its damper.

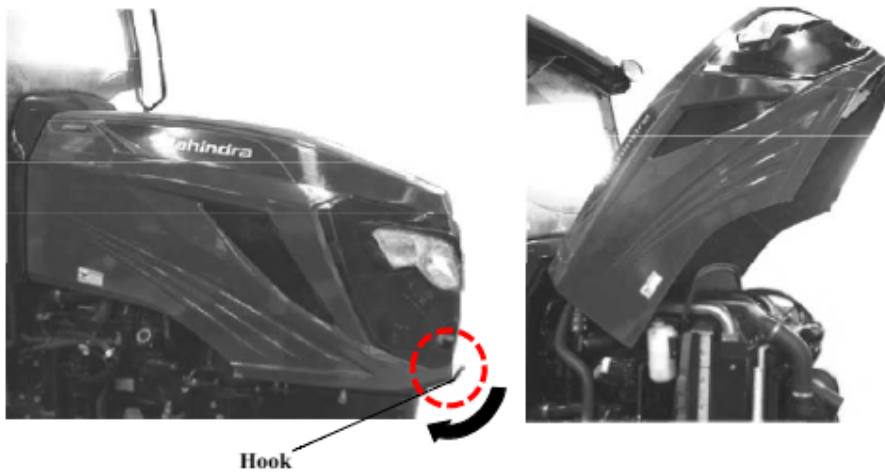

► **FUEL**

Use clean diesel fuel only (ULTRA LOW SULFUR FUEL)

 <p><b>Important</b></p>	<p>As diesel fuel equipment is susceptible to contamination by dust or water, ensure that all dust and water is kept well away from the fuel tank.</p>
---	--

## BLEEDING THE FUEL SYSTEM

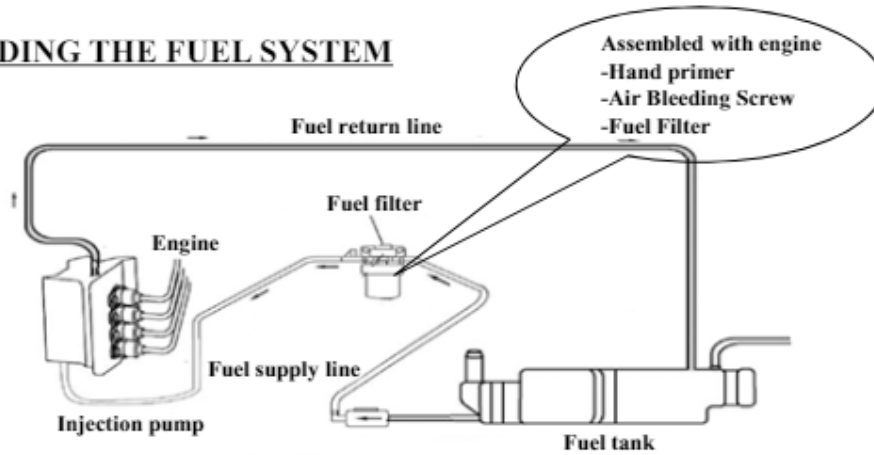

Fuel filter

## CHANGING THE OILS IN THE TRACTOR

Always use quality oils as engine or transmission oil (refer to the page 60)

Refer to the table on page 57,58 and 59 for the change frequency.

### ► Changing engine oil.

Park tractor on level surface, shut-off engine

Remove sump plug & drain oil.

Replace and check the sump plug and refill the engine with oil to the correct level on the dipstick (approx. 2.25 gal)

The grade of oil to be used will depend on the ambient temperature.

The tractor is shipped from the factory with 10W/30

For summer use over 77°F use SAE 30

For temperatures from 32°F-77°F use SAE20 or 10W/30

For temperatures below 32°F use SAE 10W

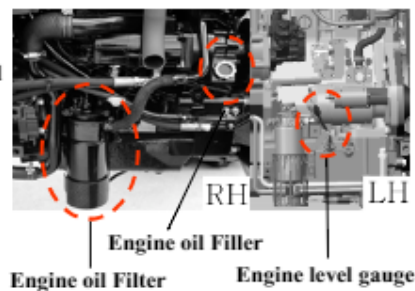



When changing the oil always change the filter.  
Always use the same oil, as using different oils or specifications can cause damage.  
Dispose of the old oil as per local regulations.

► **CHANGING THE TRANSMISSION OIL**

Remove the drain plug from bottom of the transmission and drain the oil.

Replace and check the drain plug.

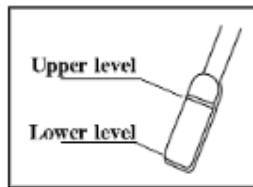

Refill the transmission to the correct level on the dipstick  
with new oil : Qty 43ℓ(11.36 US gal)

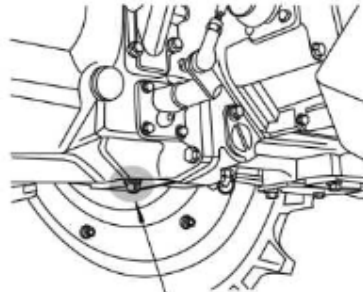

Transmission oil drain Plug

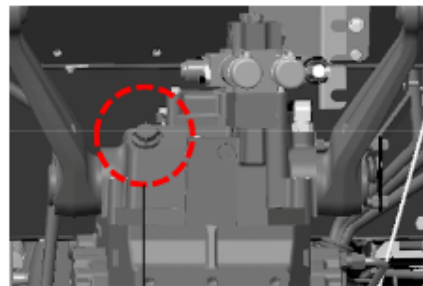

TM Oil Filler



Always use the same grade and specified oil as Replacements.  
Dispose of the old oil as per local regulations.



► **CHANGING OIL IN THE FRONT AXLE**

1. Drain the oil from the center diff plug and the drain plug in each drive.
2. Replace and tighten all drain plugs.
3. Remove the top plug (Vent plug) from each final drive to vent air from final drives.
4. Remove the dip stick from the filter hole and fill with 4.33 US gal (16.4 liters) and allow time for the oil to drain into the final drives.
5. Check the oil level with the dipstick and replace the vent plugs on both final drives and tighten.

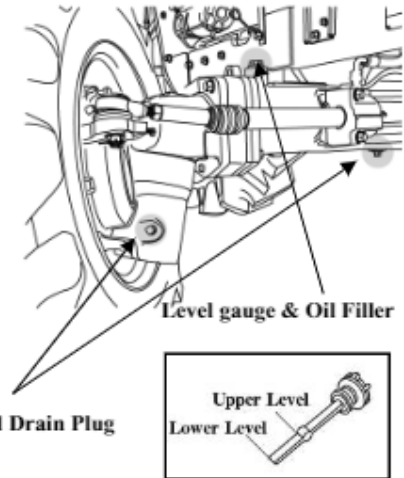

Front axle Oil Drain Plug



**Important**

Some operators have found that when they fill with the correct amount of oil and check it, the oil level on the dipstick is too high due to the fact that it takes a while for the oil to run into the final drives. Opening the Vent plugs helps to speed this up.

CLEANING AND CHANGING FILTERS

► **ENGINE OIL FILTER**

Using a filter wrench turn the filter counter clockwise to remove it. Lightly smear the rubber seal on the new filter with oil to ensure, turn it clockwise until the seal contacts the base and then turn it another 2/3 turn to tighten it.

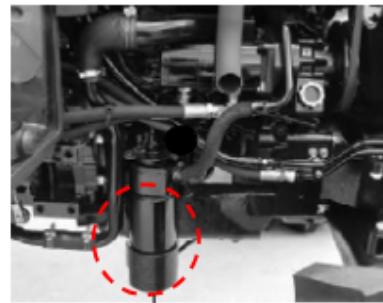

Engine oil Filter

► **FUEL FILTER**

This filter provides clean, moisture free fuel for the injection process. A hand primer is provided to manually remove excess air from the fuel filter and fuel lines.

Major Components:

- Hand Primer
- Air Bleeding Screw
- Fuel Filter

Fuel enters the filter at inlet (A) and flows through the filter element separating water its contents before flowing through outlets (B) to the fuel injection pump. Since water and contaminants settle at the bottom of the sediment bowl, a drain plug (i.e. Adaptor cum Water Sensor) is provided.

Drain water from the fuel filter when water level indicator in instrument cluster glows on.

To drain water from fuel filter, unscrew the water sensor in anticlockwise direction by hand. Rotate only 1 to 2 turns by hand. Place a small tray to collect water or water and diesel emulsion. Tighten water sensor by rotating clockwise.

Tightening torque 2 to 3 Nm or hand tighten and fix connector (C).

Servicing the Fuel Filter

1. It is recommended to replace the fuel filter every 250 hrs.
2. To remove Filter, unscrew the filter (D) from adaptor (E).
3. Check O'rings of fuel filter for any crack/damage. Smear oil on the new O'ring before installation.
4. Assemble the new filter. Do not over tighten.
5. Clean Water Sensor to remove sludge & retighten to filter.
6. Prime the system and bleed the filter. Tighten the bleeding screw.

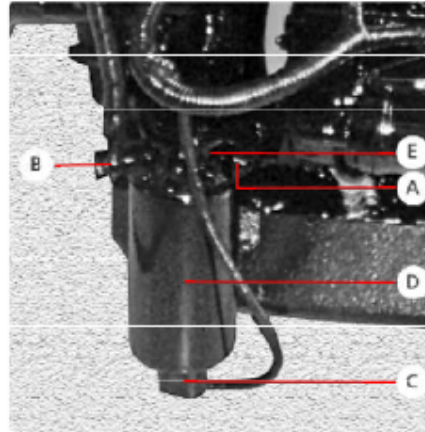

**NOTE :** Drain water once in a week or whenever the water level indicator on dashboard glows "ON" continuously, if water contamination is excessive. Continued driving with water accumulation in fuel filter will cause damage to the fuel pump / other fuel system components.

**NOTE :** Replace fuel filter at the recommended period or whenever it gets clogged. Discard the old filter and do not repair or clean the filter. Always fit the spin-on filter dry.



**Important**

Never use petrol (gasoline) thinner or similar inflammable material to wash the primary fuel filter.

After replacing the filter always bleed the system.

► **HYDRAULIC OIL FILTER AND ENGINE OIL FILTER CARTRIDGE**

Remove the filter with a filter wrench.

To replace, apply oil or grease on the seal, fit by hand until seal contacts bare, then turn it 2/3<sup>rd</sup> turn further to tighten it and check for leaks.

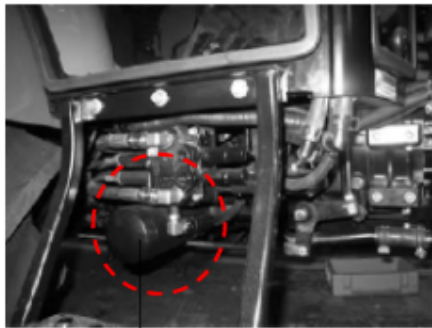

**Filter Body**

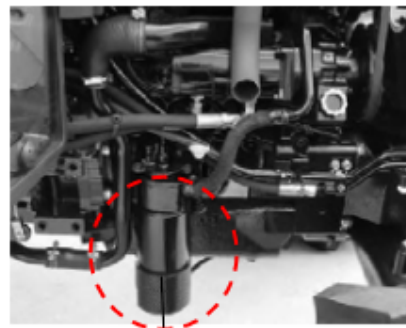

**Engine Oil Filter**

**CHANGING THE COOLANT**

- (1) Open the tap in front of the gear pump to drain the coolant.
- (2) Open the radiator cap at the same time.
- (3) To give a thorough clean run a hose into the radiator and flush it out.
- (4) Close the tap and refill the radiator with a coolant mixture of water and corrosion inhibitor or anti freeze.
- (5) Start the engine and allow it to run for approx 5 minutes, check the water level again and top off if required .

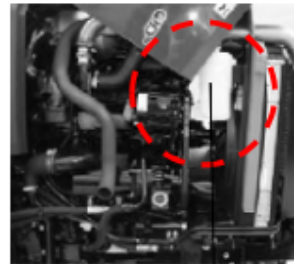

**Reservoir Tank**

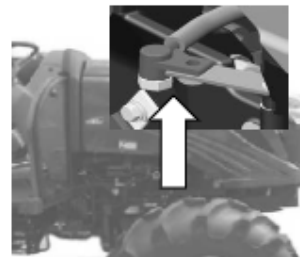

**Drain Plug**



**Caution**

Do not remove the radiator cap on a hot engine.  
Allow the engine to cool down and then turn the cap slowly to ensure, that there is no excessive pressure in the radiator.



**Caution**

Serious burns, can result from the contents of pressurized, hot radiators.  
Allow the engine to cool down completely before opening radiator.

#### ► ANTI FREEZE

Frozen cooling water can damage the engine.

Before replacing the anti freeze solution flush the radiator.

Mix the anti freeze solution in accordance with the instructions applicable to the brand of anti freeze and the local climate.

Replace the solution in the radiator.

In case of loss of solution due to evaporation or overflow, replace with the original mixture ratio.

#### ► CLEANING THE RADIATOR

Insects, grass straw and dust can all block the radiator ,condenser and reduce its efficiency.

Remove the radiator screen to clean it and radiator.

Release the bolt and pull to remove the screen.

Then clean the radiator between the fins and tube by using clean water.

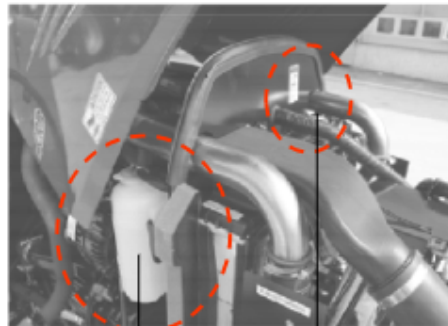

**Reservoir Tank**

**Radiator cap**



**Important**

Water or air under high pressure can distort the cooling fins on the radiator and reduce its efficiency.

**GREASING THE TRACTOR**

Grease the tractor according to the service schedule (page 57, 58 and 59.)

Ensure that grease nipples are cleaned well before any attempt is made to grease them.

► **BRAKE AREA / CLUTCH AREA**

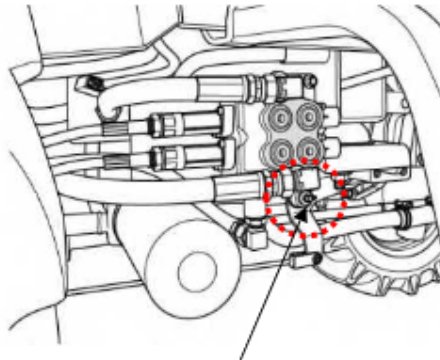

Grease Nipple

► **PIVOT METAL**

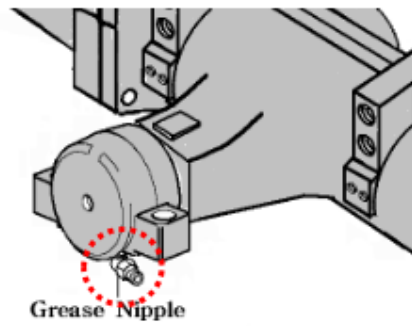

Grease Nipple

► **LIFT ROD**

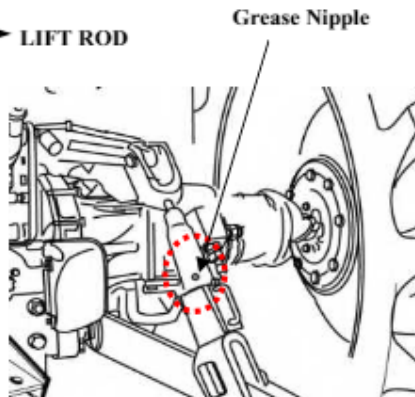

Grease Nipple

► **FRONT AXLE**

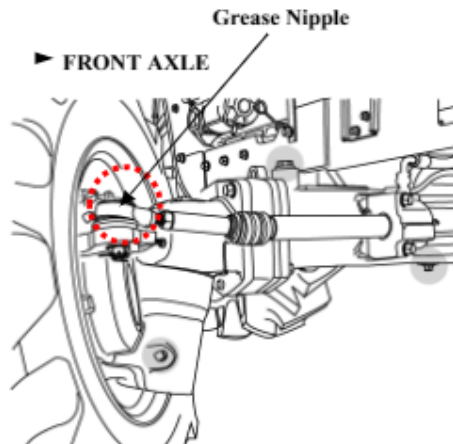

Grease Nipple

## **GAP ADJUSTMENT**

### **ADJUSTING THE CLUTCH**

Using the clutch over a period of time will increase the free play.

The correct free play of the pedal is 0.78~1.18 in

To adjust, loosen the locknut on the turnbuckle and adjust.

Check the adjustment and tighten the locknut if the free play is correct.

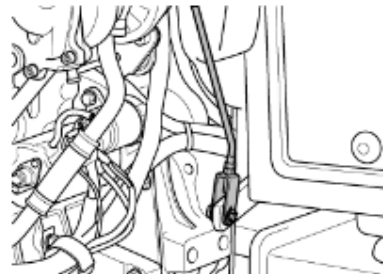

### **ADJUSTING THE BRAKES**

As is the case with the clutch, use of the brakes will change the pedal free play and the balance between the right and left pedal.

The correct pedal free play is 1.18~ 1.57 in

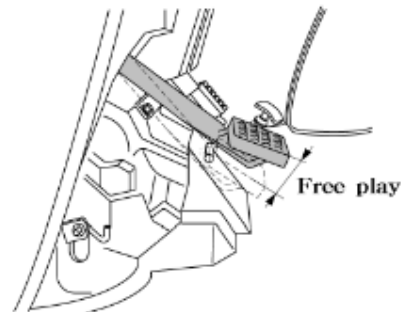

### **ADJUSTING METHOD**

Loosen the locknuts to adjust the brake.

Turn counterclockwise to increase the free play, or turn clockwise to decrease.

Tighten the locknut and confirm to fix the Nuts.

Check that the free play is correct and the same on both pedals to ensure even braking.

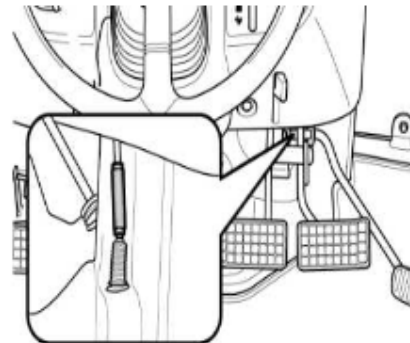



**Caution**

Uneven adjustment of the left and right pedal will result in one sided braking when the pedals are connected and can cause serious accidents, especially at high speeds.

Double check to ensure free play is the same on both pedals.

**ADJUSTING TOE-IN**

If the toe-in adjustment is incorrect it can cause severe shaking of both the steering wheel and the entire Tractor. The correct toe in is 0.08~0.24in. We recommend that this adjustment is made by the dealer.

► **BATTERY MAINTENANCE**

Low temperatures will affect the performance of batteries so take particular care of it in winter.  
For long-term storage of the tractor remove the battery and keep it in a cool dry room.  
If it is on the tractor while stored, disconnect the negative terminal.  
Batteries will self discharge if left for a period of without use time.  
To keep them in good condition charge them once a month in summer and every second month in winter.  
When replacing the original battery, ensure that the replacement battery is the same size.  
Failure to do so can cause problems with the electrical circuit.

► **BATTERY CHARGING**

-A boost charge is only for emergencies.It will partially charge the battery at a high rate and in a short time.  
-When using a boost-charged battery, it is necessary to recharge the battery as early as possible.  
Failure to do this will shorten the battery's service life.

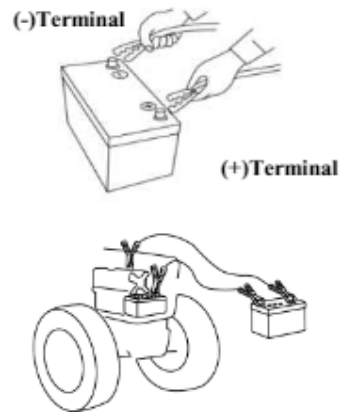

	<p><b>Caution</b></p> <p>Always disconnect the negative terminal first when removing the battery and always connect the positive terminal first when fitting the battery. When connecting the battery leads, make sure not to reverse the polarity. Quick charging will reduce battery life. Disconnect the terminals prior to charging the battery to avoid damage to the circuit and electrical instruments.</p>
--	--

**FAN BELT ADJUSTMENT**

1. Loosen the alternator pivot bolt.
2. Move the alternator in order to increase or decrease the belt tension. Tighten the alternator pivot bolt and the link bolt to 22 N.m (16 lb ft)(1)

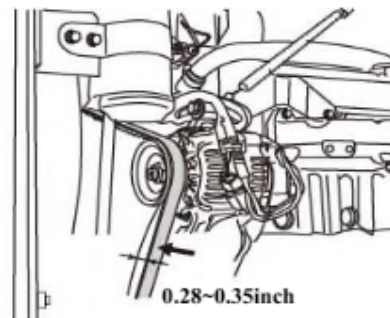



## Alternator Inspection

mahindra recommends a scheduled inspection of the alternator.

Inspect the alternator for loose connections and proper battery charging.

Inspect the ammeter (If equipped) during engine operation in order to ensure proper battery performance and/or proper performance of the electrical system.

Make repairs, as required.

Check the alternator and the battery charger for proper operation.

If the batteries are properly charged, the ammeter reading should be very near Zero.

All batteries should be kept warm because temperature affects the cranking power.

If the battery is too cold, the battery will not crank the engine.

When the engine is not run for long periods of time or if the engine is run for short periods.

The battery may not fully charged.

A battery with a low charge will freeze more easily than a battery with a full charge.

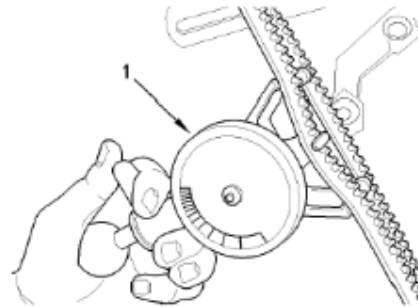

(1) Burroughs gauge.

Fit the gauge(1) at the center of the longest free length and check the tension.

The correct tension is 535N(120 lb).

If the tension of the belt is below 250N(56 lb) adjust the belt to 535 N (120 lb).

If twin belts are installed, check and adjust the tension on the both belts.

## Alternator and Fan Belts Inspect Adjust Replace

For applications that require multiple drive belts, replace the belts in matched sets.

Replacing only one belt of a matched set will cause the new belt to carry more load because the older belt is stretched.

The additional load on the new belt could cause the new belt to break.

If the belts are too loose.

vibration causes unnecessary wear on the belts and pulleys.

Loose belt may slip enough to cause overheating.

To accurately check the belt tension a suitable gauge should be used.

### **AIR CONDITIONER COMPRESSOR BELT ADJUSTMENT**

Check the compressor belt tension regularly and adjust if required.

The tension is correct when the center of the belt is pushed with a finger and it moves approx. 10 mm (0.39 in) as shown in the picture.

To adjust the belt, loosen the flange nut at compressor bracket pulley and loosen or tighten the nut as shown in the picture. Then loosen or tighten the tension bolt.

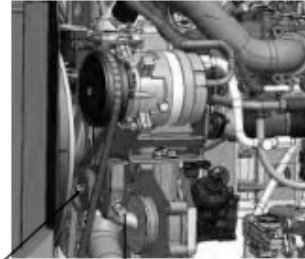

Flange nut  
Adjusting nut

### **SERVICING THE AIR CLEANER**

To remove the dust from the evacuator valve, squeeze it between thumb and fingers to let excess dust out and wipe around the valve to keep it clean from outside.

To clean the main element, remove the right fan cover. Remove the element by unloading the wing nut. Remove dust by blowing it out of the element with compressed air.

Check the element to ensure that it is not damaged. Reassemble the element.

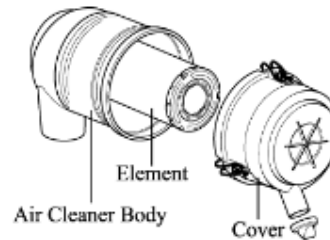

 <p><b>Important</b></p>	<p>Never beat the element on a stone or concrete floor/wall to clean it. Check all connections and hoses, especially on the clean side of the air cleaner to ensure no dusty air can enter the engine.</p> <p>Check the element for flaws by putting a light inside the element.</p> <p>When reassembling make sure all surfaces seal correctly to keep dust out.</p> <p>When working in dusty conditions increase the service frequency.</p>
---	---

► Replace the element after cleaning it 5 times or if it is damaged.

### **CHECKING HOSES AND LINES.**

The fuel lines, radiator hoses, hydraulic and rubber hoses are consumables, which deteriorate by age and use. Check them regularly and replace if faulty.

 <p><b>Caution</b></p>	<p>Damaged fuel lines leak and cause fires.</p> <p>Damaged radiator hoses can cause hot water burns and in severe cases seize the engine.</p>
---	---

### CHECKING THE WIRING HARNESS AND FUSES

Loose wires make inferior connections and damaged wires can cause short circuits, fires burnt wiring or reduce efficiency of components.

Replace or repair any faulty wiring or insulation.

If a fuse burns out again after it has been replaced, do not replace it with wire or a high capacity fuse. ,

Find the cause and rectify it or get an auto electrician to do so.

Where insulation is chafed or peeled off, recover the area with a good quality insulation tape.

Where wiring comes out of it's fitting, replace it correctly with the standard fitting.



**Important**

Incorrect wiring or fuses can cause fires to both the tractor and surrounding area, so get the dealer to check it annually.

Likewise, fuel pipes and wiring age with use.

Ask your dealer to check it at least once every 2 years and replace as required .

#### ► REPLACING FUSES

The circuit has 8 blade type fuses in its wiring circuit

(See diagram on page 99.)

When a fuse has blown, replace it with one of the same value.

Using a large capacity fuse or wire, burns out the wiring system.

Use fuse tongs to replace fuses .

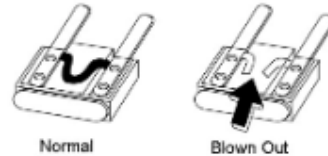

Normal

Blown Out

#### ► MAIN FUSES

The wiring harness is equipped with 3 main fuses who's function is to preserve the wiring.

However, when a main fuse blows the entire circuit is dead.

Always check the reason & rectify before replacing the fuse of the same value.

To indicate that the fuse is blown, it will be discolored.



**Important**

Always check the reason for a blown fuse otherwise the new fuse is also likely to blow.

**NEVER EVER USE WIRE** in place of correct grade fuse.

### SERVICE PRIOR TO DAILY AND SHORT TERM STORAGE.

Wash the tractor and keep it clean.

Fill the tank to avoid condensation and rust.

Lower any attached implement to the ground before parking the tractor.

For long-term storage consult your dealer.

### 3. MAINTENANCE

#### **For daily or short term storage**

Clean the tractor and remove all dirt from field work.

Fill the fuel tank to avoid condensation and rust.

Lower the implement to the ground..

Keep it in a machinery shed or, if not available cover the unit if left outside.

In very cold conditions it is advisable to remove the battery and keep it inside in a warm environment.

This will ensure effective starting when the tractor is required.

When the outside temperature is below 32°F, replace the Antifreeze completely or drain the coolant to protect the engine from damage from frozen coolant.



#### **Important**

When washing the tractor ensure that the water does not get near electrical components or the oil filter points.

To prevent short circuits remove the ignition key.

Do not wash the tractor when the engine is running.

#### **Long-term storage.**

When the tractor will not be used for a long time, carry out the cleaning as for short term storage.

Drain the oil and replace with new oil.

Run the engine for approx. 5 min. to ensure that it has new oil throughout the engine.

Drain the coolant from the radiator and remove the ignition key.

Attach a tag to both the key and the steering wheel saying "No coolant".

Lubricate all grease and oil points on the tractor.

Check the pressures and add a small amount of extra pressure.

Lower any implement to the ground or store in a shady dry place.

Disconnect the clutch by using the clutch disconnecting arm.

Place a piece of wood under each tire to preserve the tire.



#### **Important**

After refilling the engine with the coolant, run the engine for approx. 5-10 min. at 1500-2000rpm every month as a corrosion prevention measure.

Either remove the battery or the negative terminal as mouse damage to wiring can cause short circuits and fires.

Remove the ignition key and store in a safe place.

#### **Re-use after long term storage.**

Carry out a full check of all oils and coolant.

Refit the battery and run the engine at idle for 30 min. to ensure optimum engine life.

## Section - C

### CABIN

The cab fully conforms to the international standard as far as safety and soundproofing are concerned.

It can be provided with a ventilation, heating and air-conditioning system.

It is available in the following version.:

- Cab with ventilation and heating systems
- Cab with ventilation, heating and air-conditioning systems.



**Caution**

The cab is in full conformity with the international standards as to the cab's soundproofing.

Be very careful when operating in small spaces and always protect your ears whenever other working equipment is generating dangerous noise levels.

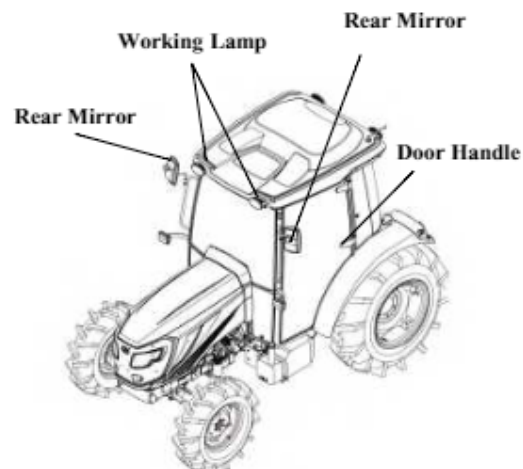
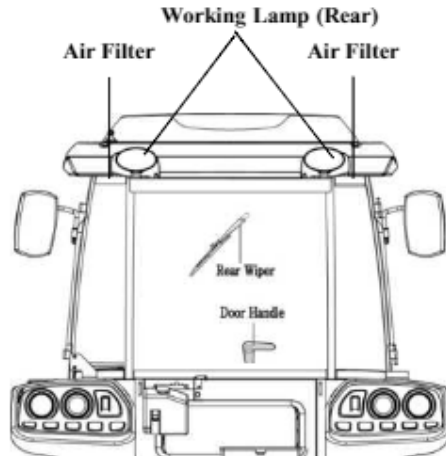



Remember that steering, braking and operational performances are highly influenced by the implements mounted, the trailers transported and the ballasts applied to the tractor.



When transporting heavy loads (exceeding the weight of the tractor) reduce the speed under 15 Km/h.



All the implements mounted onto the tractor must be safely secured.



Be very careful during implement hitching and unhitching operations. When using implement supports, be sure they are suitable and sufficiently strong.

#### ► INSTRUMENT AND RELATED PARTS

##### ■ Doors:

The doors are provided with key locks.

To open from the outside, when unlocked, pull the handle.

To open from inside, push the lever downwards.



##### ■ Rear Window:

The rear window is fitted with a central handle for opening.

When opened it is held in place by two dampers.

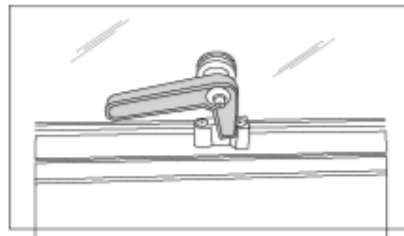

##### ■ Side Window:

The side window is fitted with a central handle for opening.

When opened it is held in place by a holder.

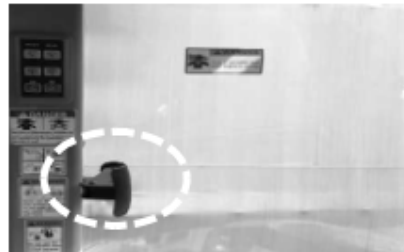

■ **Working lamps (front and rear) :**

The working lamps are located on the cab roof (two in the front and two in the rear) .

They are switched on by means of the special switches on the roof console .

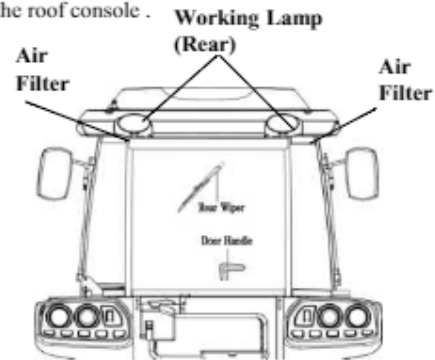
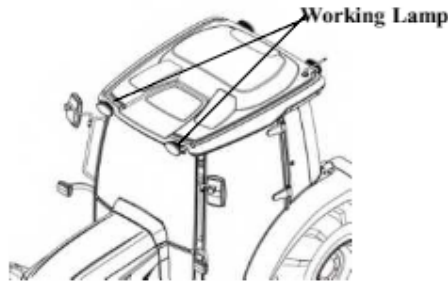

■ **Rearview mirrors.:**

The cab is provided with rearview mirrors on both sides.

They can be adjusted and folded, whenever necessary, to avoid interference with external obstacles.

The mirrors have a telescopic arm to allow positioning for maximum convenience by the user.

Remember that mirrors must always be positioned in compliance with road traffic regulations when driving on a public highway.

■ **Cab ceiling:**

The ceiling is padded with insulation material to block heat radiation into the cab and keep the temperature down when working in very sunny areas.

The cab platform is covered with a “firm grip” carpet in the most commonly used areas.

It is recommended to keep this carpet clear of earth, mud, etc. so that the operator may get on and off the tractor in full safety.

► **How to Control Cabin**

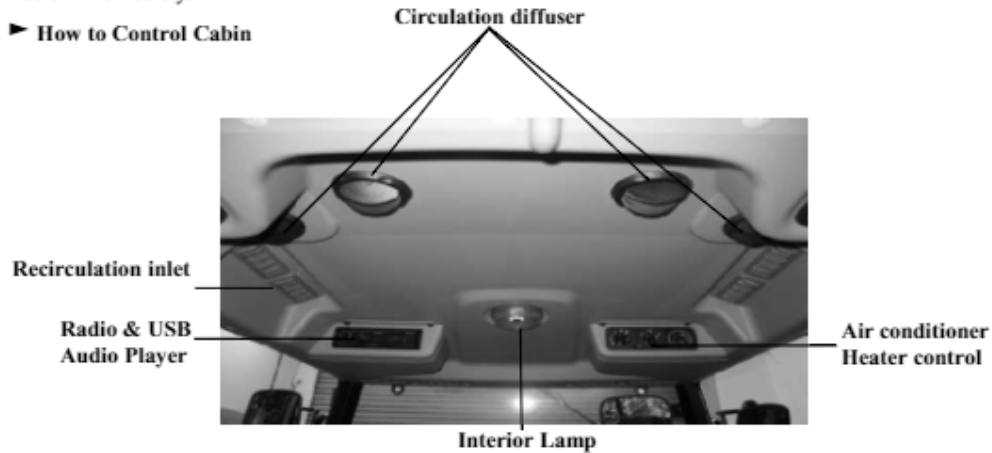

## **VENTILATION**

The ventilation unit is housed in the cab ceiling.

To switch it on and adjust it, turn the electrical fan switch to the desired speed.

The cab becomes slightly pressurized when the ventilation system is in operation, so that the fresh air can enter only by way of the filter installed in the rear section of the cab roof.

The fan switch can be operated only after the ignition key is inserted.

The air flow can be regulated and directed by suitably positioning the air diffusers.

Air can be taken in fresh from outside or re-circulated from within the cab by way of the relative side inlets

### **■ Re-circulation inlets fully closed:**

Air is taken in entirely from outside the cab through the rear grille and filtered through a paper element positioned behind the grille.

**N.B-**it is very important that the air diffusers never be completely closed so as to allow for a steady air flow.

To obtain a greater pressurization inside the cab, it is necessary to take the air from the outside, therefore the inside air recirculating grille should be fully closed.

### **■ Working lamp switch**

The front and rear working lights are ON when the button is pushed. If the work light indicator lamp is on, the instrument cluster will illuminate.

### **■ Wiper control switch**

- Switch ON

The Wiper switch is ON when the Top button is pushed.

The Washer switch is ON when the Mid-button is pushed.

- Switch OFF

Once again push the buttons.

### **■ Windscreen Washer tank**

Check the level of windscreen washer fluid in the plastic reservoir located at the front of the radiator.

During winter, it is advisable to add a suitable antifreeze or methyl alcohol to the windscreen washer fluid.

### **■ Interior Lamp**

Push the black switch to the left to turn on the light

And to the right to turn off the light.

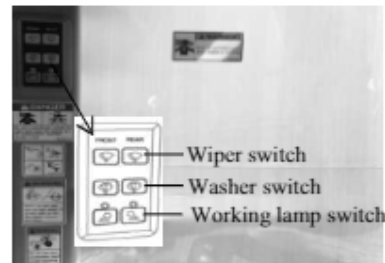

**Washer Tank**

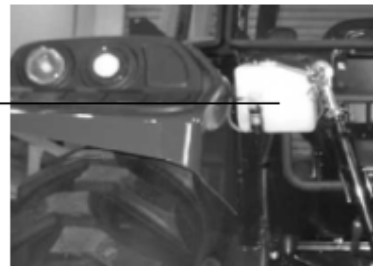

**Interior Lamp**





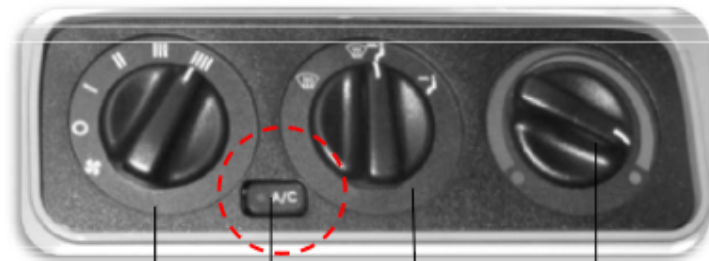

Blower control switch      A/C Switch      Air direction control switch      Temperature control

■ **Blower control switch**

Four position rocker switch

■ **Air direction control switch**

It is used to adjust the direction of air flow (3 modes)

1<sup>st</sup> position: Air blows toward the window.

2<sup>nd</sup> position: Air blows toward the window and driver.

3<sup>rd</sup> position: Air blows toward the driver.

■ **Temperature control**

Set temperature control as required, fully clockwise for maximum cool and fully counterclockwise for heat.

**1) A/C System**

**<Operation>**

1. Press the A/C Switch to turn on the A/C system.
2. For cool air, turn the temperature control switch to the right.
3. Operate the fan control switch. (4 step)

**<Precautions for using the A/C>**

1. This A/C system uses R134-a as refrigerant. Make sure to add the correct refrigerant when charging the system.
2. When adding refrigerant, add the compressor oil as well.
3. When any repairs or adjustments are needed, contact your local dealer.
4. Do not loosen or apply excessive force on any A/C hose and pipe connections.

## 2) Heater system

### <Operation>

1. To use the heater , turn the temperature control switch to the left.
2. Operate the air speed control switch . (4 Positions)
3. Warm air flows out through the vent only if the temperature of the engine coolant rises to a certain level.

### <Precautions for using the heater>

1. Make sure to use anti-freeze for the winter season. Otherwise, the engine coolant may freeze at a low temperature.
2. Check the heater hose before operation.

 <b>Warning</b>	<ul style="list-style-type: none"><li>• Prolonged operation with the A/C or heater turned on can result in suffocation. Make sure to ventilate the cabin regularly.</li><li>• Never fall a sleep in the tractor cabin.</li><li>• If refrigerant comes in contact with your skin, it can burn your skin. Therefore, the A/C system should be serviced and repaired only by experienced technicians.</li></ul>
---	--

 <b>Caution</b>	<ul style="list-style-type: none"><li>• Operating the A/C system without refrigerant can lead to insufficient lubrication and failure of the compressor. Make sure to check the refrigerant amount frequently.</li><li>• Prolonged operation of the A/C system with the tractor stationary can apply excessive load on its each part. Avoid its prolonged operation while the machine is stopped.</li><li>• If refrigerant comes in contact with your skin, it can burn your skin. Therefore, the A/C system should be serviced and repaired only by experienced technicians.</li><li>• To increase the cooling performance of the A/C system, set the engine speed over 1000 RPM.</li></ul>
---	--

## **HEATING SYSTEM**

### General description

The heater is switched on and adjusted by rotating the control knob on the roof console, then switching on the blower and setting the selector to the preferred speed .

To warm the cab up quickly, the knob should be rotated fully clockwise and the blower set to speed 3.

The screen is demisted or defrosted by air directed through a slot vent .

For defrost or fast demist, all other vents should be closed off.

### **IMPORTANT:**

Ventilation is provided by a single blower unit serving both the heating system and the air conditioning system.

After reaching the desired temperature adjust the system to suit your needs.

### **NOTE:**

-For ideal system operation, the engine must run at 1000 rpm

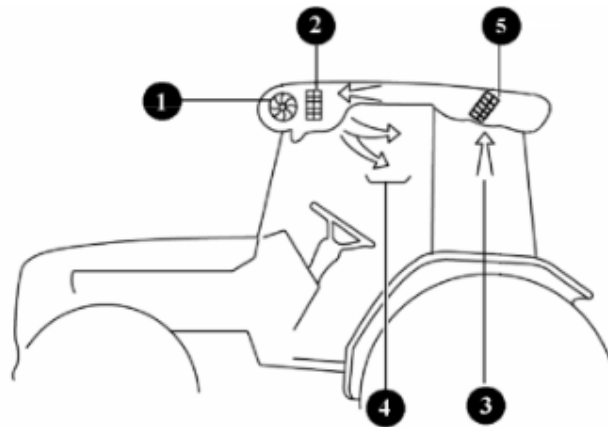

1. Speed heating fan    2. Electric resistances    3. Recirculation inlets  
4. Pivotal air diffuser    5. Air filter



**Warning**

Before starting the engine, make sure the system is off (by turning off the ventilation fan) so as not to overload the battery.  
After the system is at full power for a long period of time, never turn it off suddenly but let it first idle for about 20 seconds.

### **SYSTEM CONFIGURATION**

1.The heating system consists of two units:

1-Electric heater and blower unit installed behind the roof console.

2-Power supplying set, consisting of an auxiliary alternator located in front of the engine and driven by a belt directly linked to the engine pulley.

If the air does not come out from the diffusers right away as soon as the system is started, turn it off immediately and identify the fault.

N.B-Never turn on the heating system when working in dusty environments.

### **AIR CONDITIONER SYSTEM**

The system is designed to ensure optimum temperature inside the cab and maximum comfort and safety for the operator.

However, it is advisable to consult our specialized workshops whenever repairs or adjustments need to be performed.

Do not approach the system with open flames, as any escape from the circuit may produce a lethal gas.

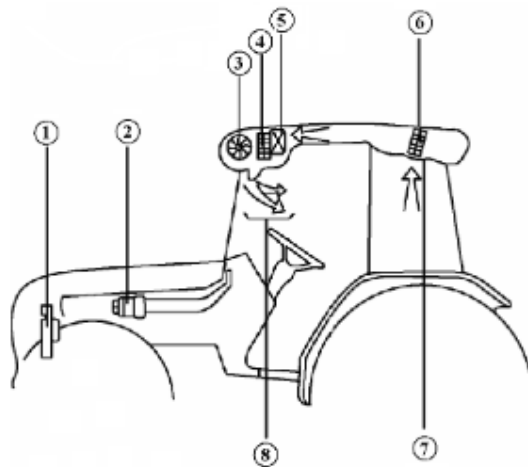

1.Alternator

2.Compressor

3.Speed fan

4.Electric resistance

5.Evaporator

6.Air filter

7.Re circulation inlets

8.Pivotal air diffusers

■ **Circulation diffuser**

With the circulation vent set in any position  
Outside air will still be pulled into the cab.



**Circulation diffuser**

■ **Radio, Bluetooth audio**

For operation refer to the Radio, USB manufacturer's  
instructions.



■ **Cup Holder**

For bottles and personal belongings.

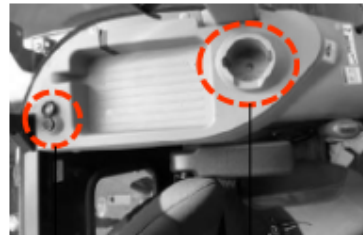

**Power socket**

**Cup Holder**

■ **Power socket**

It is possible to use a 12-V 120-W accessory by  
connecting it to the power socket.

**1. Checking the air conditioning system.**

① Environment friendly refrigerant : R134a 0.7~0.85Kg.

The presence of air and water in the system could jeopardize its efficiency.

-The air is uselessly compressed by the compressor and no cooling effect is produced.

-The moisture has a tendency to rise to obstructions which prevent the cooling efficiency.

② Check belt tension ; when finger pressure is applied to the mid-point between both pulleys.

③ Condenser fins must always be duly clean using water or an air set.

**2. Checking the air conditioning system charge**

(1) Check the refrigerant charge.

A. Run the engine at 1500rpm.

B. Set the air conditioning system to the coldest for 5 minutes.



C. Check the sight glass clear or cloudy.





**Caution**

If the air-con. is operated without being charged.  
the lubrication in the compressor can cause damage.

► Check the refrigerant via the receive drier sight glass

	Bubbles or foam visible	Trouble shoot	
	<ul style="list-style-type: none"> <li>● Bubbles flow and refrigerant gas disappears like a fog</li> </ul>	<ul style="list-style-type: none"> <li>● Deficient of refrigerant Replenish</li> <li>● Nothing different temperature between H.L pipe</li> <li>● High pressure of the pressure gauge needle indicates low pressure.</li> </ul>	Abnormal
	<ul style="list-style-type: none"> <li>● Same bubbles appear occasionally (1~2 sec. gap)</li> </ul>	<ul style="list-style-type: none"> <li>● Replenish the refrigerant</li> <li>● High pressure pipe is hot and low pressure pipe is a little cool.</li> <li>● H.L pressure of the pressure gauge needle indicates low pressure.</li> </ul>	Abnormal

	Bubbles or foam visible	Trouble shoot	
	<ul style="list-style-type: none"> <li>● No bubble shown</li> <li>High-pressure pipe is abnormally hot.</li> <li>H-L pressure of the pressure gauge needle indicates abnormally high pressure.</li> </ul>	<ul style="list-style-type: none"> <li>● Too much refrigerant deflate.</li> <li>● High pressure pipe is not abnormal</li> <li>● H.L pressure of the pressure gauge needle indicates high abnormally.</li> </ul>	Abnormal
	<ul style="list-style-type: none"> <li>● Refrigerant in the sight is shown clear.</li> <li>● When engine RPM operates with high low, some bubbles disappear slowly</li> </ul>	<ul style="list-style-type: none"> <li>● Normal refrigerant gas situation</li> <li>● High pressure pipe is hot. Low pressure pipe is cool.</li> <li>● High low pressure is normal with below.</li> </ul> <p>Low: 1.5~2.0kg/m<sup>2</sup> High: 14.5~15 kg/m<sup>2</sup></p>	Abnormal

### 3.Diagnosing malfunctions.

#### (1) Tracing faults

	SYMPTOM	CONDITION	CAUSE	REMEDY
1.Compressor	Abnormal sound	Inlet sound Outlet sound	Insufficient Lube.	Replenish
			Belt tension release	Adjust
			Release the bracket	Tighten the bolts
			Clutch fail	Check
	Abnormal revolution	Inlet cause Outlet cause	Damaged parts	Check,replace
			Slip the clutch	Check,replace
			Not Lub.	Replenish
	Refrigerant or oil leakage	Refrigerant or oil leakage	Sealing washer damaged	replace
			Head bolt released	Tighten the bolts
			D-ring damaged	Replace
Excessive pressure	Low,High pressure	Insufficient refrigerator	Adjust	
		Compressor	Replace	

	SYMPTOM	CONDITION	CAUSE	REMEDY
2.Motor	Weak from pressure or doesn't work	Motor is normal	Air inlet clogged	Remove
			Evaporator freezing	Controlling minimum pressure
			Ventilator switch damage	Replace the switch
			Compressor	Replace
		Motor is abnormal	Motor failure	Replace
			Wire cut	Replace
	Air leakage	Duct leakage	Check,tighten	
	Unable to control the fan	Motor	Air volume control switch failure	Check,tighten
Motor is abnormal		Motor failure	Replace	
3.Clutch	Noise	Regular noise Irregular noise	Interference with pulley	Control the compressor direction
	Disengage	Engaged sometimes	Wire defect	Check wire
		Engaged to push with hand	Clutch gap large	Adjust
			Low voltage	Check battery
	No defect wire	malfunction	Replace	
	Slip	Slip during rotation	Low voltage	Check battery
			Oil stick at clutch	Clean
Malfunction			Replace	

(2) How to check the air conditioning system with the needle of high low gauge

To connect with the manifold pressure gauge, one can investigate the air conditioning system. Because the manifold pressure gauge varies sensibly (Ambient Temp. is based on 30~35℃)

Caution:

Operating E/G RPM 1500~2000 is a must, so that you can check the correct cause and air conditioning.

(in the case below, the figure of indicated pressure gauge has some clearance, confirm with approximate

indicated needle data.)

Gauge pressure conversion

● lb/in<sup>2</sup>-PSI

● 1 kg/cm<sup>2</sup>=14,223 in<sup>2</sup>

(Ex) 200 PSI=14 kgf/cm<sup>2</sup>



**Section - D**

## **Specifications**

The specifications on the following pages are given for your information and guidance.

For further information concerning your Tractor and equipment, consult your Authorized Mahindra Dealer/ Distributor.

Mahindra policy is one of continuous improvement and the right to change prices, specifications or equipment at any time without notice is reserved.

All dates given in this book are subject to production variations.

Dimensions and weights are approximate only and the illustrations do not necessary show Tractors in standard condition.

For exact information about any particular Tractor, please consult your Mahindra Authorized Dealer Distributor.

## SPECIFICATIONS

**Model: 2670 PST CAB**

### ENGINE

**Four strokes, Indirect injection, water-cooled Diesel Engine.**

Model	: VNEF Engines
No. of cylinders	: 3
Displacement (in <sup>3</sup> )	: 161.5
Bore (in)	: 3.78in
Stroke (in)	: 4.80in
Compression Ratio	: 17.2:1
Rated power	: 70HP@2300 rpm
(Manufacturing rating)	
Rated Speed(rpm)	: 2300
High idle (rpm)	: 2,500±50 RPM
Low idle (rpm)	: 850 ±50
Fuel pump	: Bosch CP4 16/10 HW
Fuel injector	: Bosch CRI 2-16 OHW
Cylinder sleeve	: Wet Replaceable
Air Cleaner	: Dual Dry
Exhaust Muffler	: Horizontal External type
Firing order	: 1-3-2
Accelerator	: Hand & Foot Accelerator

### ELECTRICAL STARTING AND LIGHTING

Battery Capacity	: 12 Volt 100AH
Starter	: 3.6kW Heavy Duty Starter Motor, Solenoid engaged.
Alternator	: 12V 90A
Instrumentation	: Water Temperature Gauge, Tacho meter, Hour meter, Electrical fuel level gauge.

Lighting:	Head lamps, side indicators, Rear parking brake & indicator light On dash board indicators for battery charging, turn signal, PTO signal, Engine oil pressure, Preheat signal.
-----------	--

### CLUTCH

Type	: Wet multi plate
------	-------------------

### TRANSMISSION

Type	: Power Shuttle
No. of gears	: 12 forward, 12 reverse speeds with Differential Lock
<b>STEERING</b>	: Hydranlic/Tilttable

### POWER TAKE OFF

Rear mounted	: 6 splines
Diameter	: 1½ in.(35mm)
Standard PTO	: ⓐ 540

### BRAKES

Foot operated, independent with provision of inter lock for simultaneous operation. A foot brake is fitted for parking.	
Disc Diameter	: Φ184mm(Φ7.24in)
Number of lining	: 5 each side
Total brake thickness	: 29.5mm(1.16in.)

### HYDRAULIC SYSTEM

Independent fully "Live" hydraulic pump and separate reservoir. Position controls with isolating & response control

Hitch Lift capacity	1430kgF
at 24 inches behind link ends	

Pump output	: Main - 19.5 cc/rev (44 ℓ/min)
	Steering - 8 cc/rev (18 ℓ/min)

Delivery(91% efficiency) : liter(cu. in)/mm at 2300rpm

3 point linkage : Category II

► MAIN SPECIFICATIONS

Model		2670 PST CAB	
Engine	Manufacturer	Mahindra	
	Model	VNEF	
	Type	Indirect injection, vertical, water-cooled, 4-cycle diesel	
	Number of Cylinders	3	
	Total Displacement cm <sup>3</sup> (cu. in.)	2648(161.5)	
	Gross Power kW (HP)	52(70)	
	Rated Speed rpm	2300	
	Maximum Torque N-m (lbf-ft)@ rpm	264(194.7)@1500	
Electrical System	Battery	12 Volt, 100AH	
	Alternator	90A	
Drive Train	Transmission Type	Power Shuttle	
	Number of Speeds	F12 / R12	
	Brakes	Wet disk ,Mechanical	
	Steering	Hydraulic/Tilttable	
	Clutch	Wet multi plate,Electro-hydraulic	
Hydraulic system	Pump Capacity (Main) gpm (L/min)	11.8(44.9)	
	Pump Capacity (Power Steering) gpm (L/min)	4.9(18.4)	
	Number of standard remote valves (Additional Option)	1(2)	
3 Point Hitch	Type	Category II	
	Lift Capacity	Lift Points lb (kg)	3527(1600)
		24-in. Behind Lift Points lb (kg)	3153(1430)
	Lift Control Type	Mechanical - Position/Draft	
PTO	Type	Independent	
	Control	Electric/Hydro	
	Mid (Option) rpm	-	
	Rear rpm	-	
	Shaft Diameter in. (mm)	540rpm : 1-3/8 in. (35mm), 6 Splines	
Fluid Capacities	Fuel Tank, gal. (L)	18.5(70)	
	Cooling System qt. (L)	9.5(9)	
	Crankcase (with filter) qt. (L)	7.1(6.7)	
	Trans.& Hydr. System gal. (L)	11(42)	
	Front Axle qt. (L)	17.4(16.5)	
Dimensions	Overall length with 3-Point Hitch in. (mm)	144.4(3667)	
	Overall width in. (mm)	71.1(1805)	
	Overall Height in. (mm)	101.6(2580)	
	Wheelbase in. (mm)	73.7(1872)	
	Min. Ground Clearance in (mm)	14.5(370)	
	Min. Turning Radius without brakes in. (mm)	145.2(3690)	
Weight with ROPS or Cab			4630(2100)
Tire	AG	Front	9.5x20 6PR
		Rear	14.9x28 6PR
	IND	Front	10.5/80x18 6PR
		Rear	18.4x24 8PR

Model			2670PST CAB	
TYPE	DIVISION	TYRE TYPE	TIRE INFLATION (1bf/in <sup>2</sup> )	TREAD (inch)
AG	FRONT	9.5-20PR TL Hi Trac Lug	30psi	60.9
	REAR	14.9-28PR TL Hi Trac Lug	20psi	55.2
IND	FRONT	10.5-/80-18PR TL Hi Trac Lug	40psi	63.2
	REAR	18.4-24PR TL Hi Trac Lug	28psi	54.5

Traveling Speed (Km/hour)			
MODEL		2670 PST CAB	
Range shift	Main shift	Forward	Reverse
L	1	0.90	0.92
	2	1.42	1.46
	3	2.19	2.24
	4	2.72	2.79
M	1	2.87	2.94
	2	4.54	4.65
	3	6.99	7.16
	4	8.69	8.90
H	1	9.41	9.64
	2	14.90	15.27
	3	22.92	23.49
	4	28.50	29.20

\*The specifications are subject to change for improvement without notice.

## FUEL SAVING TIPS

To save fuel & oil in your tractor, the following should always be kept in mind.

### **A) Air cleaning system**

- 1) Clean the air cleaner regularly so that dust does not settle down.
- 2) For every 50 hours & everyday in sandy/dusty conditions.
  - (a) Clean the air cleaner filter element with compressed air.
  - (b) If the rubber ring is cut or expanded then change it with an appropriate one.  
Fix the rubber ring at the proper location & check for leakages if any.
  - (c) If air is leaking through the hose connection, check & rectify other leakages, too.

**Note:** If air cleaning system is not properly maintained, it will lead to early wear of piston rings & sleeves.

This will lead to problems like loss of engine power,, excessive oil consumption and/or fuel consumption.

### **B) Engine**

- 1) Put the engine oil on load after the engine is heated & the water temperature gauge indicates the needle to be in the green zone.
- 2) If excessive black smoke is visible, then the paper element of the air cleaner, Fuel injection Pump or nozzles should be checked.
- 3) Do not run the engine without load for more than 2 minutes.  
It is better to stop the engine rather than run it idle.  
This will help in saving of fuel.

### **C) Clutch & Brakes.**

- 1) Do not reduce the power of the engine by depressing the clutch halfway.  
Instead use low gear.
- 2) If the Tractor has to be stopped for a long period, it is advisable to bring the transmission to neutral position & release the clutch pedal.
- 3) Do not over ride the clutch & brake pedals.
- 4) While coming down from a slope, reduce the engine throttle & use low gear.  
Do not depend only on the brakes for stoppage.

### **D) Fuel system**

- 1) Always use filtered diesel for the fuel system
- 2) At the end of the day's working, it is preferable to fill the diesel tank so that it may prevent condensation.
- 3) Change the filter, if the system gets choked.  
Do not change both the filters at the same time.  
If the above directives are not adhered to, the fuel injection pump & injection nozzle will lose its life early.  
Also, it will lead to excessive black smoke & excessive diesel consumption.

**E) Engine system**

- 1) Always use recommended grade of oil.
- 2) Everyday before starting the engine, check the oil level with a dipstick & refill between the minimum & maximum level.
- 3) Change the engine oil, Replace filter & "O" ring, as & when required.

**F) Cooling system**

- 1) Check the fan belt tension regularly.  
Adjust, if required.
- 2) Check the coolant level in the radiator fins always clean.
- 3) Replace the radiator cap with a genuine cap only, if required.
- 4) Do not remove the thermostat but replace it with a new one, if required.
- 5) Do not change the radiator water often.

**Note:**

- 1) Always stop any fuel or oil leakages.
- 2) Carry out the regular maintenance, failure to do so might increase the fuel consumption by 25%.
- 3) Carry out the torque of cylinder head bolt & adjustment of valve clearance regularly.  
Consult your dealer for this.
- 4) Check the tire pressure & inflate, as recommended.
- 5) Always buy genuine spares from the authorized Dealer/Distributor.
- 6) Always carry out the service of the Tractor by your authorized Dealer/Distributor.

For any other information, contact your nearest Authorized Dealer/Distributor.

**FAULT TRACING**

	SYMPTOM	CAUSE	REMEDY
Engine	Turning the main switch will not operate the starter	Clutch not pushed in Battery flat  Switch faulty	Push the clutch in Charge or replace the battery Dealer to repair or replace Contact dealer for repair or replace
	Starter operates but not enough to turn the engine	Low battery Bad earth Thick oil	Charge the battery Clean the earth lead and tighten Drain and replace with correct oil
	Starter operates OK but does not start the engine	Air in fuel system Clogged fuel filter No fuel being supplied Glow plug disconnected or not working	Bleed the system Clean or replace both filters Fill tank or turn tap on Contact dealer for repair.
	Engine revolutions are irregular	Air in the fuel system Faulty injector Fuel pipe leak	Bleed the system Contact dealer for repair.
	The engine stops at low revolution	Poor fuel injection Faulty injection pump Wrong valve clearance Wrong idle setting Faulty injector	Contact dealer for repair Contact dealer for repair Contact dealer for repair Contact dealer for repair Contact dealer for repair
	The engine stops suddenly	Lack of fuel  Faulty injectors Seized engine due to lack of oil, the wrong oil or lack of coolant	Fill the tank and bleed the fuel system Contact dealer for repair
	The engine overheats	Lack of coolant Broken or misadjusted fan belt Clogged air filter element Clogged radiator Low oil	Refill with coolant Adjust or replace  Clean or replace air filter Clean the core Replace the oil to correct grade



	SYMPTOM	CAUSE	REMEDY
Engine	White smoke from the exhaust	Oil level too high Shortage of or faulty fuel	Reduce to correct quantity Contact dealer for repair
	Reduced performance of the engine	The injectors are clogged, carbon coated and sticking Low compression Leaking valve seat Incorrect valve gap Faulty timing Fuel shortage  Clogged air cleaner	Contact dealer for repair  Contact dealer for repair Contact dealer for repair Contact dealer for repair Contact dealer for repair Fill the tank and check fuel quality Clean the element
	Oil warning light comes on with the engine running	Low oil level Wrong oil Faulty light or switch Clogged oil filter	Fill to correct level Change to correct oil Replace faulty part Contact dealer for repair
	Alternator light comes on with the engine running	Wiring fault Faulty alternator Low water level or faulty battery Broken or loose fan belt	Contact dealer for repair Contact dealer for repair Top up or replace Replace or adjust

	SYMPTOM	CAUSE	REMEDY	
Clutch	The clutch slips	Incorrect adjustment	Adjust to correct free play	
		Worn or burnt lining	Contact dealer for repair	
	The clutch does not disengage	Incorrect adjustment Rusty clutch lining	Adjust to correct free play Contact dealer for repair	
Brake	Brake not working	Incorrect free play Worn or burnt lining Left and right gap different	Adjust to correct free play Contact dealer for repair Equalize	
	Brake pedal not returning	Faulty return spring Lack of grease on the joints	Replace spring Remove rust and lubricate with grease	
Hydraulic system	Hydraulics are not lifting	Engine revs. too low Lack of transmission Oil Air leaking in from a pipe Clogged suction filter Faulty pump Faulty hydraulic valve Faulty cylinder	Increase engine revs. Top up the oil to the correct level Repair or replace pipe or replace O ring on joint and tighten  Clean and change oil Contact dealer for repair Contact dealer for repair Contact dealer for repair	
		Oil leak from pipe	Loose pipe joint Cracked pipe	Tighten joint Replace or repair pipe
		When lifting the relief valve whistles	The stopper has slipped down	Adjust the stopper
For any other hydraulic problems please consult your dealer who has the correct equipment to diagnose and repair the system				

	SYMPTOM	CAUSE	REMEDY
Steering wheel	Steering wheel shaking	Wrong toe-in Unequal tire pressure Loose component	Adjust toe-in Inflate both to correct pressure Tighten or replace if worn
	Excessive play in the steering	Worn steering shaft Worn components	Contact dealer for repair Contact dealer for repair
Electric instruments	Flat battery	Faulty wiring  Faulty alternator Faulty regulator Broken or loose fan belt	Repair, reconnect or tighten as needed Contact dealer for repair Contact dealer for repair Replace or adjust
	Before anything else, check the electrolyte level of the battery and the connections. Top Off if required and clean and retighten the terminal.		
	Dim head lights	Low battery Faulty wiring	Charge or replace Repair or replace as needed
	Headlights not working	Blown bulb Blown fuse Faulty contact	Replace bulb Replace fuse Repair or replace and check the earth
	Horn not working	Faulty horn button Faulty wiring Faulty horn	Replace button Repair or replace Replace
	Indicator not working	Blown bulb Faulty flasher unit Faulty wiring	Replace bulb Replace unit Repair or replace

### Wiring Diagram

- ▶ Drawing for fixing the position of the fuses
- ▶ Wiring diagram of the electric instruments

1	5A	10	V9
2	5A	11	V5
3	10A	12	V0
4	10A	13	V5
5	10A	14	V01
6	10A	15	10A
7	10A	16	V01
8	30A	17	V0
9	30A	18	V5
9	10A	19	V01
FUSE TONGS		9	10A
PULLER		9	5A

1. HAZARD LAMP
2. PANEL B+
3. CABIN B+
4. FRONT WORKING LAMP
5. REAR WORKING LAMP
6. REAR WIPER
7. FRONT WIPER
8. A/C
9. SPARE FUSE
10. ECU
11. METER PANEL
12. CONTROLLER
13. HEAD LAMP/HORN
14. DIAGNOSTIC/SPEED
15. CABIN
16. TURN SIGNAL LAMP
17. STOP LAMP
18. BUZZER
19. EXT. POWER

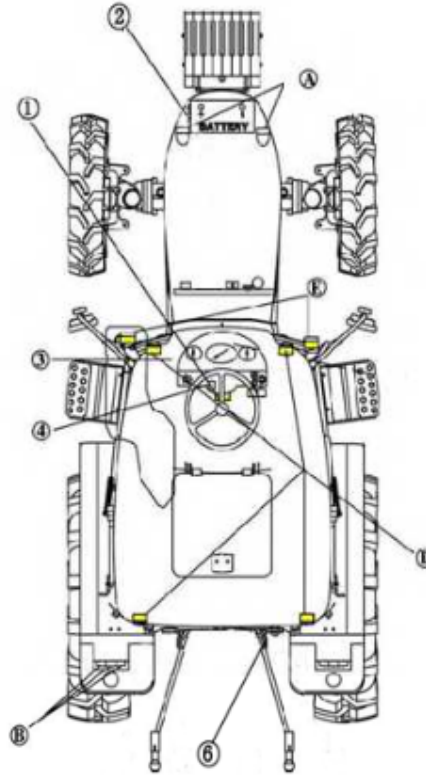

1	FUSE BOX
2	SLOW BLOW FUSE
3	UNITS FOR DIRECTION SIGNAL RELAY FOR THE POWER
4	PTO MONITOR
6	COUPLER FOR THE TRAILER

A	HEAD LAMP	12V HS1 35/35W
	SIDE WORKING LAMP	12V 5W
B	DIRECTION SIGNAL LAMP	12V 21W
	STOP LAMP BACK LIGHT	12V 21/5W
D	WORKING LAMP	12V 37.5W
E	DIRECTION SIGNAL LAMP	12V 27W

**TRACTOR HISTORY CARD**

<b>DATE</b>	<b>JOB CARD NO.</b>	<b>NATURE OF DEFECT</b>	<b>PARTS REPLACEMENT</b>	<b>W/CLAIM NO. AND DATE</b>	<b>REMARK S</b>

**SERVICE RECORD**

<b>DATE</b>	<b>TRACTOR HOURS</b>	<b>NATURE/TYPE OF REPAIR/SERVICE CARRIED OUT</b>

**DAILY OPERATION LOG**

DATE	JOB DONE	MACHINE HOURS		FUEL CONSUMPTION	ENGINE OIL TOPPED UP	REMARKS
		START	END			

**PART REPLACEMENT RECORD**

<b>DATE</b>	<b>PART DESCRIPTIO N</b>	<b>Q'TY</b>	<b>COST</b>	<b>DATE</b>	<b>PART DESCRIPTION</b>	<b>Q'TY</b>	<b>COST</b>





**2670 PST CAB**

Operator's Manual For Tractors

Code No.

1232-940-001-0

Printed in May. 2019

2nd Edition

