

# mahindra | 6000 SERIES



UTILITY TRACTORS



**OFFICIAL  
TRACTOR  
OF TOUGH™**

**62-71 HP**  
ENGINE

**4**  
WHEEL DRIVE

**3,609 LB.**  
LOADER LIFT

**5,950 LB.**  
HITCH LIFT

**5-YEAR**  
LIMITED POWERTRAIN  
WARRANTY



*"I'm pushing 5000 hours on my Mahindra 6065.  
I have not had to replace anything except routine  
maintenance parts. It's reliability is incomparable."*

**— Kyle Perry**

Dreamland Wildlife Properties, Homer, MI



**OFFICIAL  
TRACTOR  
OF TOUGH™**

# 6000 SERIES

UTILITY TRACTORS

## THIS ONE IS ALL BUSINESS.

We are not playing. The Mahindra 6000 4WD utility tractor, with its impressive 62-71 hp powertrain and more than 3 tons of iron, is the job foreman in our lineup. We've eliminated the Diesel Particulate Filter and regeneration, which would interrupt your work. It comes with a loader that hoists nearly 2 tons at 11 feet high, and a 3-point hitch that manhandles 3-ton implements. And we've included a new state-of-the-art climate-controlled cab and mComfort seat with air-ride suspension for the ultimate office. Truly, this is the ideal teammate for anyone who has little time to waste.

[www.mahindrausa.com](http://www.mahindrausa.com)

### IDEAL USES

Brushcutting large tracts

Forestry management including fire breaks, & road & ditch maintenance

Hay farming including cutting, tedding & baling

Livestock care & feeding

Municipality maintenance

Professional landscaping including clearing and contouring land

Row crops including cultivating & harvesting

Snow removal for parking lots & roads

## THE ADVANTAGES

**LEAN & MEAN ENGINE:** The Mahindra 6000 features a 3-cylinder, 62-71 hp, mCRD™ (common rail diesel) engine with a turbocharger and intercooler. Its Tier 4-compliant engine eliminates the diesel particulate filter (DPF), diesel exhaust fluid (DEF), and regeneration to keep your Mahindra working.

**UNEQUALED LIFT CAPACITY:** Get even more done in less time with an all-new factory-installed loader and 3-point hitch. You'll also have more choices in attachments and CAT 1 and 2 implements.

**UNSURPASSED COMFORT:** Mahindra's climate-controlled cab, ergonomic operator station, power steering, and mComfort seat work together to alleviate strain on those long work days.

**BUILT STRONG:** The 6000 4WD utility tractor comes with large, heavy tires, more than three tons of weight, and long wheelbase for superior performance, durability, and stability.

**COMPELLING WARRANTY:** Get a 5-year/3,000-hour, no-deductible limited powertrain warranty supported by more than 450 dealer locations.





# GETTING BUSINESS OFF THE GROUND.

The Mahindra 6000 Series front loader lifts over 3,600 pounds over 11 feet high. It'll store round bales three rows tall, place materials onto a roof or second floor, and even move feed and haylage into a mixer wagon. We dare you to find a better loader in the utility tractor class.



133  
131  
129  
127  
125  
123  
121  
119  
117  
115

## HYDRAULIC LOADER VALVE

Mahindra 6000 Series with Power Shuttle Transmissions (PSTs) come standard with a single loader valve with dual spools. Raise and level your bale spear, bucket, or forklift attachment simultaneously for faster loader work.

## OPTIONAL 3RD FUNCTION VALVE

If you want a grapple, auger, snowblower, or broom to fit your loader, you'll need a hydraulic-powered third function.

## LOADER SELF-LEVELER

Do you need to move water totes or costly cargo like an HVAC unit? Our mechanical self-leveler provides optimal material handling control, making forklift tasks a breeze.



**METAL HOOD** While many competitors use plastic hoods, we made ours from metal to better protect the engine. (1)

**EASY MAINTENANCE** We have designed an easily accessible engine for self-service. It can be unlocked via a pull lever and raised to 80°. (2)

**HEAVY-DUTY, HEAVY-WEIGHT** The 6000 Series with loader, weighing more than 8,000 lb., is optimally counterbalanced. As a result, it can safely lift up to 3,609 lb. using the front loader and 5,950 lb. using the rear 3-point hitch.

**HEAVY-DUTY GRILL GUARD** When doing loader work, it's common to bump obstacles. Our grill guard is tougher than most items that get in your way. (3)

**QUICK-CONNECT ATTACHMENTS** Attaching a Mahindra bucket, blade, forks, or bale spear takes only a few seconds with our skid steer tool carrier connections. (4)

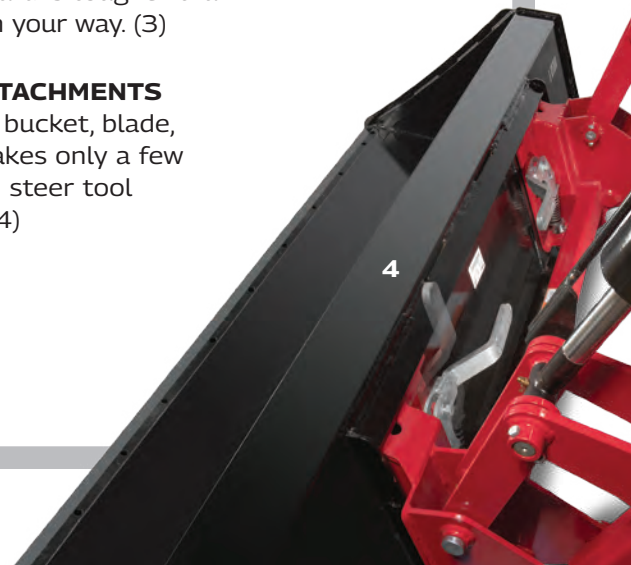



*"I maintain almost 400 acres. Some people say I'm in the cow business but truthfully I'm in the grass-growing business. I own two tractors, a Mahindra 6065 and a Mahindra 6075. Mahindra is the best value, so I'm going to buy a third."*

**— James Hunter**  
Hunter Farms, Bostwick, GA



**OFFICIAL  
TRACTOR  
OF TOUGH™**



# GETTING DOWN TO BUSINESS.

"Rest is for the weary," says anyone with a Mahindra 6000 Series. With over 3 tons of iron, built-in CAT1 and CAT2 connectors for attaching to dozens of implements, and a 3-point hitch lift capacity of 5,950 pounds\*, this producer hustles until quitting time.



**STRONG PTO** Among the three market leaders, we offer the strongest power take-off (PTO) solution. Our engine can transfer an impressive 53.5-61 hp to the PTO. Additionally, we have included a low-noise "E" economy mode, which helps save fuel.

**VERSATILE CAT 1 & 2 HITCH** Connect to dozens of implements using our flexible ball-pivot. It rotates within its housing to CAT 1 (5A) or CAT 2 (5B) positions. Moreover, our 3-point hitch also comes with telescopic stabilizers and flex links for superfast, single operator connections.

**CLEVIS HITCH** Our clevis hitch comes standard on every 6000 Series tractor and is great for pulling attachments like trailers, finish mowers and spreaders. For added safety, the rear hitch has a spring-loaded locking pin in addition to the lower ring pin. (6)



# GET MORE WITH THE MAHINDRA 6000 SERIES.

Get a Tier 4 engine that eliminates needing a DPF, DEF, and regeneration. Discover the best transmission for loader work and a herculean 3-point hitch for connecting numerous CAT1 and CAT2 implements. Sit in the most comfortable and intuitive operator station while cooling off in a second-to-none climate-controlled cab. Get peace of mind with a top-notch warranty and excellent safety features that protect you and your investment for years to come.

**SAFETY** Some safety features, all made standard in our 6000 Series tractors, include:

- A retractable seat belt
- Hydrostatic power steering to reduce driver fatigue and improve overall tractor control
- High-visibility headlights & taillights
- A low-profile ladder with a climbing grab rail
- Flat operator platform to minimize tripping
- Roll-over Protective Structure (ROPS)

**BEST-ALL-AROUND TRANSMISSION** Choose a mechanical or power shuttle with five forward and reverse gears at three ranges, providing smooth directional control. With 15 forward and reverse speeds, this feature enables fast and efficient front-loader work.

**GO-ANYWHERE 4WD** The Mahindra 6000 Series 4-wheel-drive tractors quickly plow through snow, mud, and flooded fields. Heavy front axles boost stability, making loader work safer and faster.







**FUEL TANK LOCATION**

Refilling a fuel tank atop the engine is back-breaking and will lead to spills. The 6000 Series is located near ground level protected by the tractor's frame. (7)



**POWER-ASSISTED STEERING WITH MECHANICAL TILT**

Our power-assisted steering with mechanical tilt improves driver control while improving dashboard visibility. It absorbs vibrations to reduce arm fatigue too. (8)



**FLAT TOP FENDERS** Our fenders are wide to eliminate mud sling and flat for mounting useful items like a toolbox, chain saw, and a radio. (9)

**REAR WORK LIGHT**

Adjustable work light improves visibility when using implements in low light or dark-thirty. (10)



**EASY ENTRY** We added a low-profile two-step ladder for smaller operators. (11) And we added a solid hand grip for easy entry. (12)



**mCOMFORT SEAT** No lawnmower seat here. It's the industry's most innovative recliner with contoured cushions, armrests, and adjustable legroom to reduce vibration and fatigue. (12)

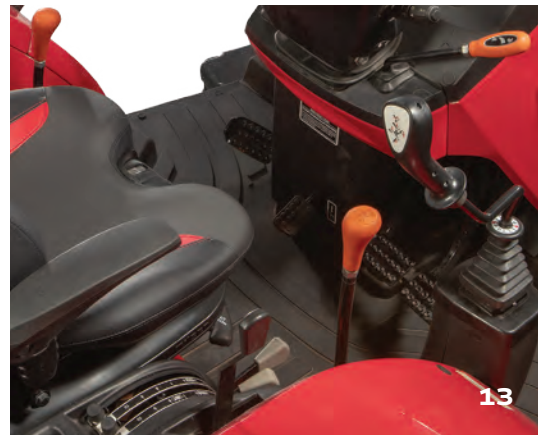

**FLAT PLATFORM** We engineered our operator platform to be flat. This reduces tripping hazards and provides maximum real estate for your feet when seated. Our tractor comes with an anti-slip rubber floor mat too. (13)

# A COZY OFFICE

We redesigned the roomy ROPS cab to double as your workspace. Don't miss anything with its wraparound view. Fire up the heat or ice down the cabin with its powerful AC. Gaze through the convenient sunroof to verify loader height clearance. Choose the peace and quiet in the sound-dampened cabin or enjoy music through radio-ready surround sound system. Charge your phone while working, ensuring you stay connected all day.



14



## **CAB FEATURES** Include:

- Roll-Over Protective Structure
- Two side mirrors
- A rearview mirror
- HVAC & features touch panel
- Ventilating sunroof with cover
- Adjustable front sunshade
- Wraparound windows
- Front wiper
- Easy-access wide doors
- Cabin lighting
- 4 front and 2 rear LED lights
- Storage trays with cup holders
- USB power socket
- 2-speaker sound system

## **HVAC PANEL**

No matter the temperature outside, you control the cabin temperature. (14)



15

**SUNSHADE** Forget your sunglasses? No worries. Lower the forward-facing, adjustable sunshade. (15)



*"My son loves the Mahindra 6075 climate-controlled cab. We operate year-round, so the winter heat and the summer AC make farm work comfortable. On top of that, the enclosed cab has eliminated my son's persistent allergy issues."*

**— Andrew Rutledge**  
Equine Heart Healers Ranch, Ware Shoals, SC



**OFFICIAL  
TRACTOR  
OF TOUGH™**



# IMPLEMENT YOUR PLAN WITH MAHINDRA.

The Mahindra 6000 Series tractor gives you access to dozens of implements, thanks to its heavy-duty powertrain, hefty weight, impressive PTO power, CAT 1 & CAT 2 3-point hitch linkage, and time-saving draft control. This is a one-tractor-fits-all. For a more extensive lineup of attachments, ask about our implement brochures.



Pallet Forks



Bale Spears



Blades



Rock Buckets

*"After my son researched the best value of the major brands, we chose the Mahindra 6075. We use it for bushhogging, cultivating, spreading fertilizer and seed, cutting and baling hay, and feeding livestock. There isn't anything this tractor won't do. Its a beast."*

**— Andrew Rutledge**

Equine Heart Healers Ranch, Ware Shoals, SC





4-in-1 Buckets



MD & HD Rotary Cutters



Box Scrapers



Augers



Rear Blades



CAT 2 Quick Hitch

# mahindra mCRD

## ADVANCED ENGINE TECHNOLOGY

Mahindra's state-of-the-art, mCRD (common rail diesel) engine results from a \$30 million engineering investment. Our eco-friendly, fuel-injected powertrain guarantees:

- Better engine performance
- Superior PTO horsepower
- No Diesel Particulate Filter
- Reduced fuel consumption
- High-power output; Low RPMs
- Strong warranty

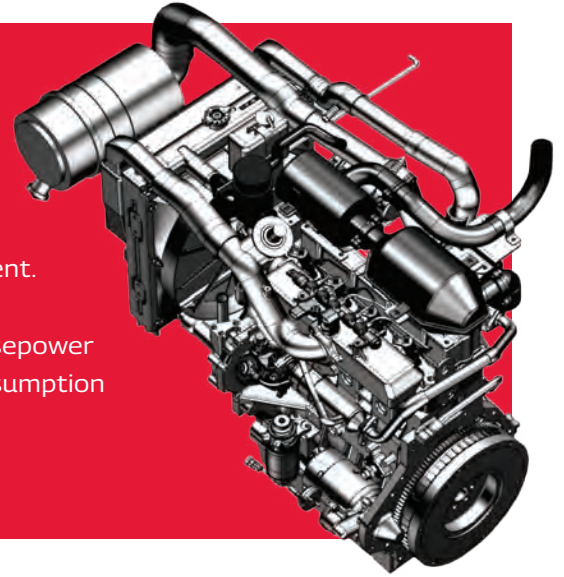

## 0% REGEN. 100% PRODUCTIVITY.

Mahindra's MCRD engine removes a Diesel Particulate Filter (DPF). That means...

- No regeneration downtime
- Fewer parts to replace
- No high heat
- No wasted warranty hours
- No wasted fuel
- Quieter operation

### ATTACHMENT SPECIFICATIONS

BACKHOE	6075 4WD	LOADER	6075L
Maximum Digging Depth (in / cm)	112 / 284	Maximum Lift Height (in / cm)	133 / 338
Digging Depth 2ft Flat Bottom (in / cm)	110 / 279	Digging depth (in / cm)	5.5 / 14.0
Digging Force-Bucket (lb / kg)	3895 / 1767	Lifting capacity full height at pivot pin (lb / kg)	3609 / 1637
Digging Force-Dipper (lb / kg)	2358 / 1070	Breakout force (lb / kg)	5000 / 2268
Shipping Weight (lb / kg)	1100 / 499	Shipping weight (lb / kg)	1880 / 853

#### BACKHOE FEATURES Include:

- Dig depth of 9'-4"
- 18-inch bucket standard
- Optional mechanical thumb
- Easy installation & removal
- Intuitive controls
- Spacious, comfortable station
- Protected grease points for long life

#### LOADER FEATURES Include:

- Skid steer tool carrier system for ultra-fast attachments hookup
- Single loader valve with dual spools to perform simultaneous loader functions
- Upgrade with optional 3rd function valve for a grapple or an auger
- Precision linkage fittings for attachments
- Mechanical self-leveler





## TRACTOR SPECIFICATIONS

MODEL	6065 SHUTTLE	6065 PST	6065 PST Cab	6075 PST	6075 PST Cab
<b>ENGINE</b>					
Brand & Model	Mahindra VNEM 363		Mahindra VNEM 373		
Type	Four stroke, turbocharged, intercooled, common rail direct injection, water cooled diesel engine, comply with US Tier-4 Final				
Cylinders	3				
Engine HP (kW @ RPM)	62 (46.2) @ 2100		71 (52.9) @ 2100		
Compression Ratio	17.2:1				
Cylinder Sleeve	Wet Replaceable				
Displacement (in <sup>3</sup> / cm <sup>3</sup> )	161.6 (2650)				
Exhaust System	DOC / Under-hood muffler / Up swept exhaust / NO DPF				
Fuel Tank Capacity gallons (L)	23.8 (90.0)				
<b>ELECTRICAL</b>					
Battery Capacity	12V, 925 CCA				
Alternator	12V, 55A Alternator	12V, 140A Alternator	12V, 55A Alternator	12V, 140A Alternator	
<b>TRANSMISSION</b>					
Type	15F / 15R Full Synchro Mesh Speed and Constant Mesh Range				
Shuttle Type	Mechanical shuttle with dry clutch	Power shuttle with wet clutch and torsional damper			
<b>STEERING</b>					
Type	Hydrostatic power steering, with tiltable steering column				
<b>BRAKES</b>					
Type	Oil immersed brakes, lever actuated parking brake				
<b>HYDRAULIC SYSTEM</b>					
Type	Open center with position and draft control, telescoping stabilizers and flex links				
Implement Pump Output Main (GPM / LPM)	11.1 (41.6)				
Total Pump Output (GPM / LPM)	15.7 (59.3)				
3 Point Linkage	CAT 1 & 2				
3 Point Lift Capacity @ Lower Links (lb / kg)	5952 (2706)				
Hydraulic Outlets	Single auxiliary valve with detent and float (2nd & 3rd optional)	Double auxiliary valves with with detent and float (3rd optional)			
<b>PTO</b>					
Type	2 speed independent single lever type 1 PTO (dry clutch)	2 speed independent push button type 1 PTO (wet clutch)			
PTO HP (kW)	53.5 (39.9)		61 (45.4)		
PTO RPM @ Engine RPM	540 @ 1993 and 540E @ 1469				
<b>VEHICLE WEIGHT</b>					
Total Weigh (lb / kg)	6416 (2916)	6548 (2976)	7495 (3407)	6548 (2976)	7495 (3407)
<b>DIMENSIONS*</b>					
Overall Length (in / mm)	152.7 (3879)				
Overall Width (in / mm)	82 (2083)				
Overall Height (in / mm)	106 (2692)	115 (2921)	106 (2692)	115 (2921)	
Wheelbase (in / mm)	87.4 (2220)				
Ground Clearance (in / mm)	15.5 (394)				
Turning Radius w/ Brakes (ft / m)	12.5 (3.8)				
Turning Radius w/o Brakes (ft / m)	13.5 (4.1)				
<b>TIRES</b>					
Ag (Front / Rear)	11.2 - 24 / 16.9 - 30				
Industrial (Front / Rear)	43 x 16-20 / 18.4 - 28				

\* Dimensions based on Ag tires; Specifications and design subject to change without notice.



**mahindra**

9020 Jackrabbit Road, Suite 600

Houston, Texas 77095

(877) 449-7771

**[mahindrausa.com](http://mahindrausa.com)** **[mahindracanada.ca](http://mahindracanada.ca)**



LOCATE A DEALER

*Mahindra USA, Inc., reserves the right to change the stated specifications without notice. This brochure is for descriptive purposes only and reasonable efforts were made to verify the information contained in it. Some items shown may be optional and some machinery shown may not be available at all dealers. Mahindra disclaims all representations and warranties, express or implied, or any liability from the use of this brochure. For complete warranty, safety, and product information, consult your local Mahindra dealer and the product operation manual. Engine power (hp/kw) and other specifications are based on various standards and best practices. This brochure is intended for the United States and its territories only. For more information visit our website.*

**Rev 07092024**